

SPIRAL2 SC Linac:

Four Years of Beam Delivery and Future Perspectives

Omar Kamalou

on behalf of the GANIL/SPIRAL2 teams

Grand Accélérateur National d'Ions Lourds
GANIL — CEA | CNRS — Caen, France

IPAC 2026 | Deauville, France | May 2026



Heavy Ion Source



Low β (0.07) section



High β (0.12) section



NFS

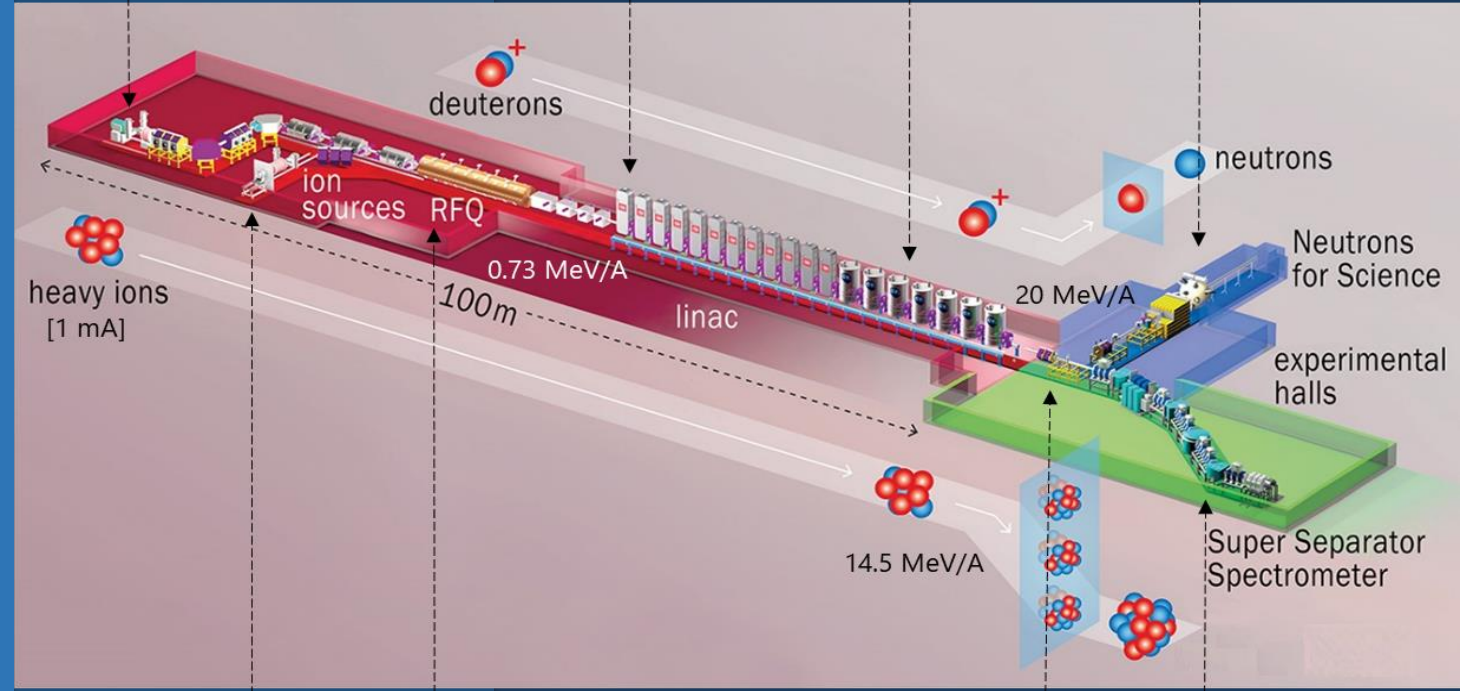

H^+/D^+ source



RFQ



SBS



HEBT



S³

Outline

Part 1: Introduction — GANIL facility and SPIRAL2 linac architecture

Part 2: Four years of operations (2022–2025) — beam time overview

Part 3: Machine studies — LLRF tuning, cavity compensation, pressure

Part 4: Key highlights — heavy-ion acceleration and first S^3 beam

Part 5: Future perspectives — DESIR, NEWGAIN, SIMS, SAGA

Conclusions: Key takeaways

01

Part 1

Introduction

GANIL facility overview and SPIRAL2 linac architecture

GANIL is one of the world's leading ion-beam research laboratories (CEA–CNRS, Caen)

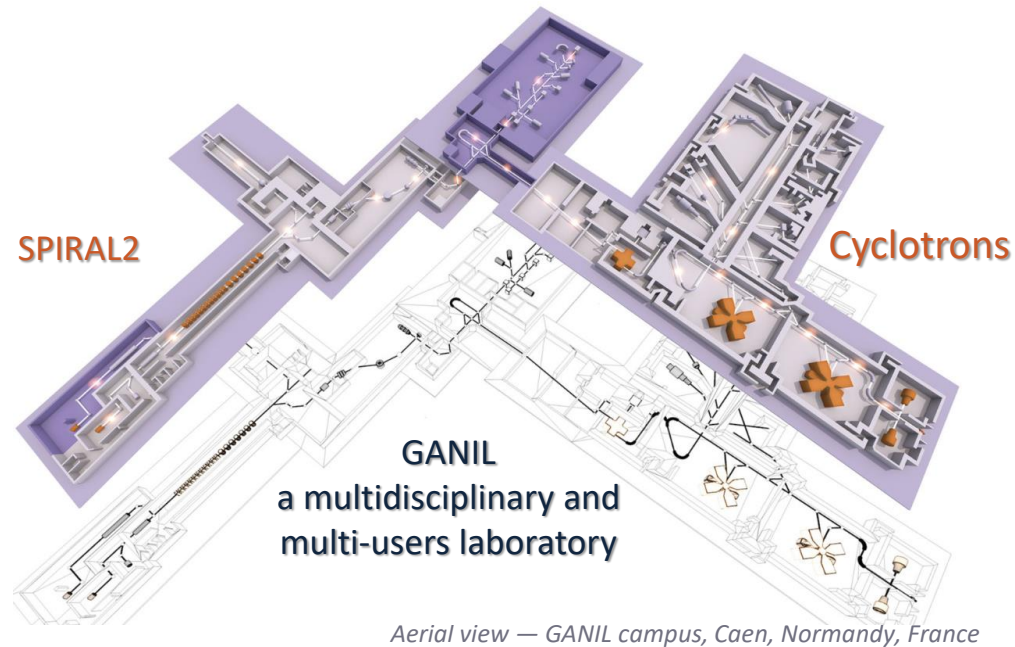

Key facts

Joint CEA–CNRS facility, operational since 1983

~400 users/year from 30+ countries — fully multi-disciplinary

Nuclear physics, atomic physics, materials science, radiobiology

SPIRAL2 superconducting linac: operational from 2019

International partners: BARC, INFN, IFIN-HH, IFJ-PAN, SOREQ ...

SPIRAL2 mission

Produce high-intensity stable beams ($A/Q=1-3$) to drive NFS and S^3 experimental rooms

1972

Start of the Project
CNRS - CEA



2001

First beam
SPIRAL1



2019

First beam
SPIRAL2



1983

First beam delivered to
the physics



2005

Start of the project
SPIRAL2



SPIRAL2: 29 SC cavities at 88 MHz accelerate $A/Q=1-3$ from 0.73 to 14.5 MeV/u

Particles	H ⁺	D ⁺	ions	NewGain
A/Q	1	2	3	7
Max I (mA)	5	5	1	1
Max energy (MeV/u)	33	20	14	7
Max beam power (kW)	165	200	44	49

Collaboration with National Laboratories
and International Partners

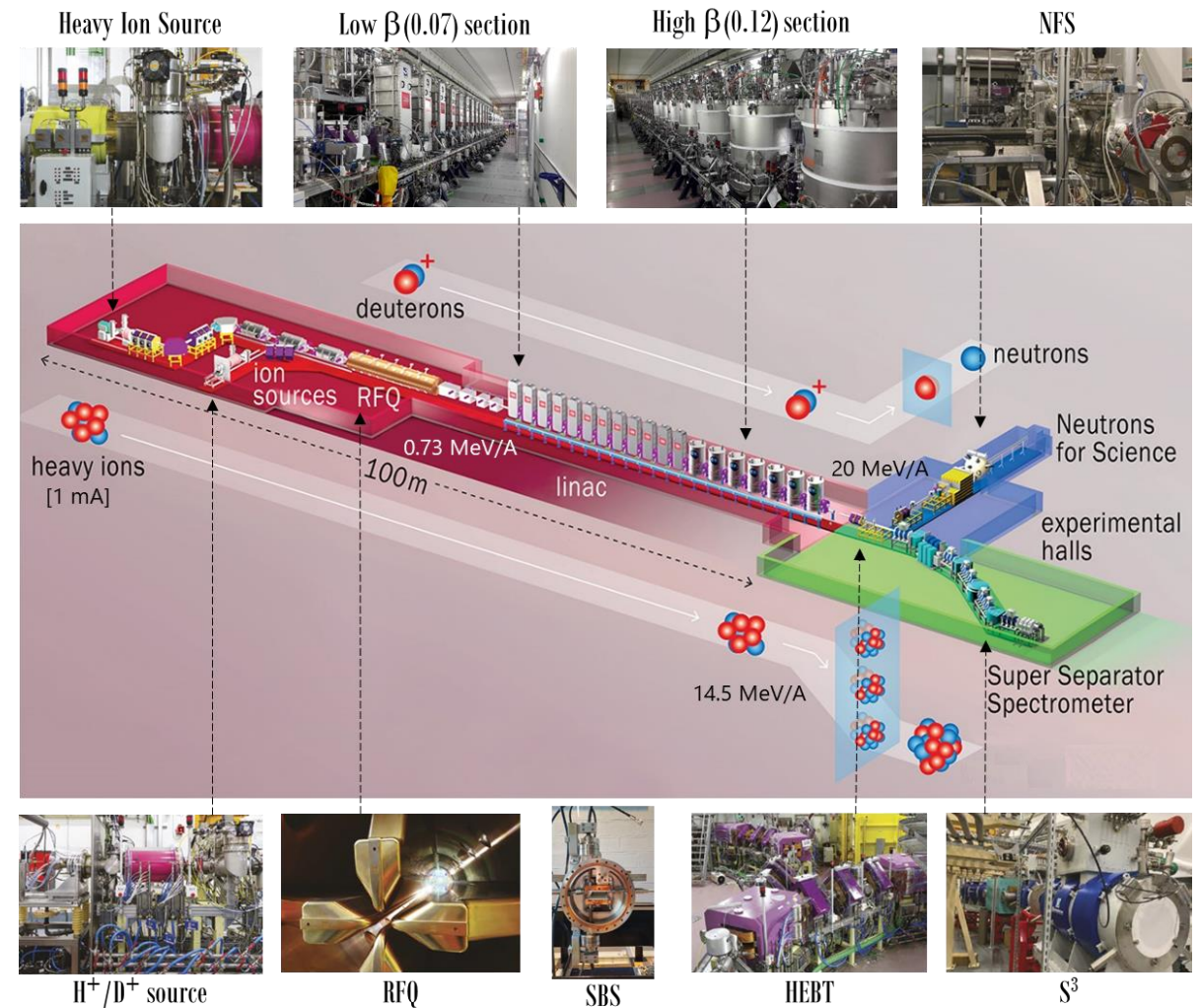

SPIRAL2 SC linac — from ion sources to NFS and S3 experimental rooms (Source: GANIL/SPIRAL2)

Superconducting linac

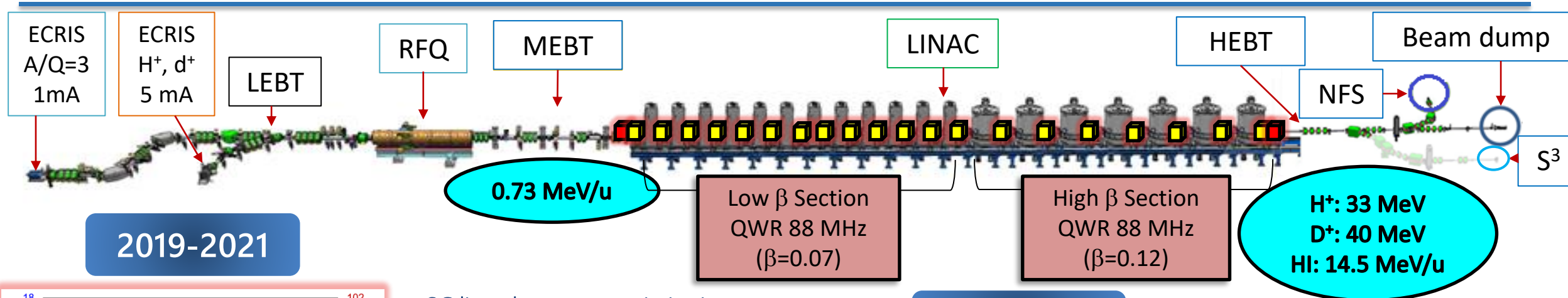

2019-2021

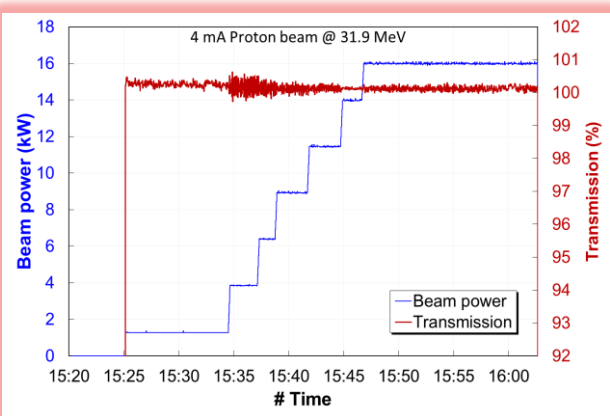

A.K. Orduz et al., Phys. Rev. Accel. Beams, vol. 25, pp. 060101, 2022. doi:10.1103/PhysRevAccelBeams.25.060101

SC linac beam commissioning up to the main beam dump

Authorization to operate SPIRAL2,
Jul 8th, 2019

1st beam in the linac, Oct. 28th

Characterization and first experiments in the NFS room

2019: 33MeV H⁺, 1st beam in NFS

2020: 16 kW H⁺, 40 MeV ⁴He²⁺

2021: 10 kW D⁺, 50 μ A D⁺ NFS

2022-2025



Four years of SPIRAL2 operation

Pre-commissioning for S³
7 MeV/A ¹⁸O⁶⁺, ¹⁸O⁷⁺, ⁴⁰Ar¹⁴⁺
0.73 MeV/A ¹⁸O⁶⁺, ¹⁸O⁷⁺, ⁴⁰Ar¹⁴⁺

2 kW
14.5 MeV/A, ¹⁸O⁶⁺ (2023)

Linac Tuning with a missing cavity
Linac pressure variation

Ready for all type of ions, intensities and energies

02

Part 2

Four Years of Operations

— beam time breakdown and milestones

Physics beam time

25 physics experiments,
10 beam dynamics studies and
First milestone of the S^3 experimental
room commissioning 2024

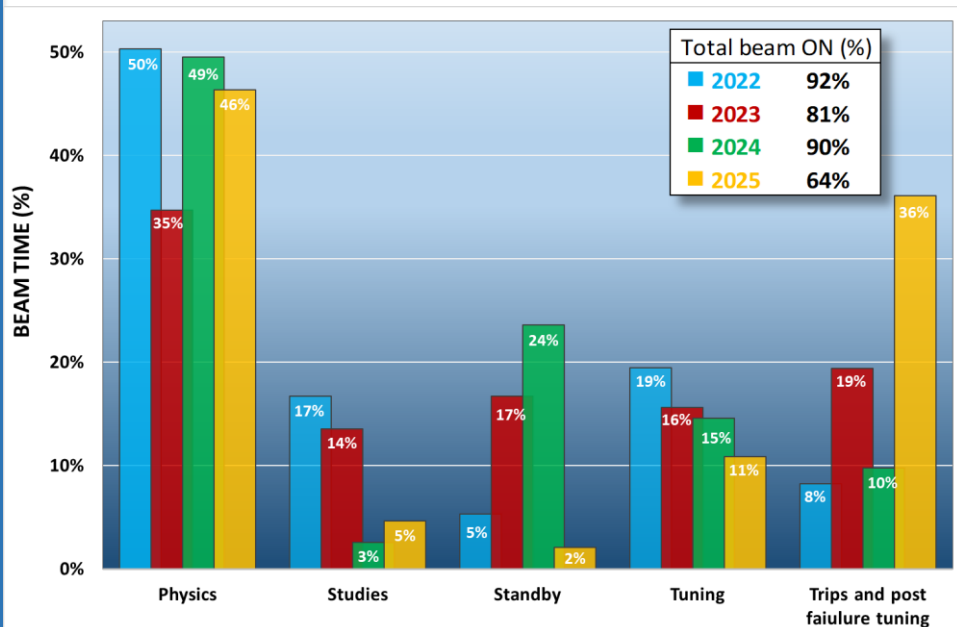

R. Ferdinand et al., Proceedings IPAC'26

Key observations

- 2022:** 50% physics, 92% beam-ON — best first year
- 2023:** 35% physics — RF studies + HI commissioning
- 2024:** 49% physics, 90% ON — most efficient year
- 2025:** 46% physics, 64% ON — cavity #11 failure. No impact

Beam parameters

- Species:** H^+ , D^+ , $4He^{2+}$ — 0.75 to 40 MeV
- D^+ current:** 20 nA to 5 mA (6 orders of magnitude)
- On target:** 47 uA with 1/100 SBS duty cycle
- SBS:** Bunch selector — key for neutron TOF experiments

Notable experiments

- Neutron cross-section data for ENDF/JEFF libraries (80 % for NFS)
- REPARE: ^{211}At production with $^4He^{2+}$ — cancer therapy R&D
- Industrial neutron irradiation (SAGA/Nucleotides)

SPIRAL2 operation feed back

- Maximum power reach today: **16 kW** for H^+ , **10 kW** for D^+ **2 kW** for **heavy ions**
- X-ray emissions in 2 cavities. Maximum voltage was reduced of around 8% to avoid this problem and compensated by increase the field in other cavities (8 MV/m max available for some cavities vs 6.5 MV/m nominal). Ongoing study in Plasma Processing of Cavities at IJLab.
- The boron nitride plates of the H^+/D^+ source need to be replaced every 1000 hours/ H^+ and 500/ D^+ .
- **Cavity 11 degradation 2024-2025**
 - RF losses increased significantly, making it impossible to achieve the nominal field strength of 6.5 MV/m.
 - RF losses deteriorate irreversibly when attempts are made to push the cavity's accelerating field beyond 5 MV/m.
 - July 2025: During maintenance, the vacuum team discovered a leak in cavity #11.
- **Operation without Cavity CMA11 2025**
 - **Cavity failure compensation studies**
 - **D^+ has been accelerated at nominal energy without losses for a month and half**
 - Tuning made using the reference method.
 - **5 Nuclear** physics experiments and **1 Industrial** experiment
 - **3 Research/machine studies:** neutron characterisation, Cavity compensation, SAGA project

2025 : Operation without cryomodule CMA11

- **Cryomodule removed:** special case, avoid risk.
- **Study** in the cleanroom at **GANIL**.
- 1. Verifications:
 - Cavity side: No visual defects
 - Cavity base: Discolouration of the copper coupler port (overheating?)
 - Coupler:
 - Discolouration of the coupler at the top:
 - indicating high-temperature heating $>200^{\circ}\text{C}$ minimum
 - Oxidation along the coupler but not near the ceramic or at the top
 - No apparent defects on the ceramic
 - Carbon-coated detection sensor.
- 2. **High Pressure Rinsing** treatment at GANIL
- 3. **Test** at **IJCLab** for **performance validation** -> 9.5 MV/m
- 4. Reassembly
- 5. Test without connection to the warm sections
- 6. Final connection tests (reinstallation of various safety devices, etc.)

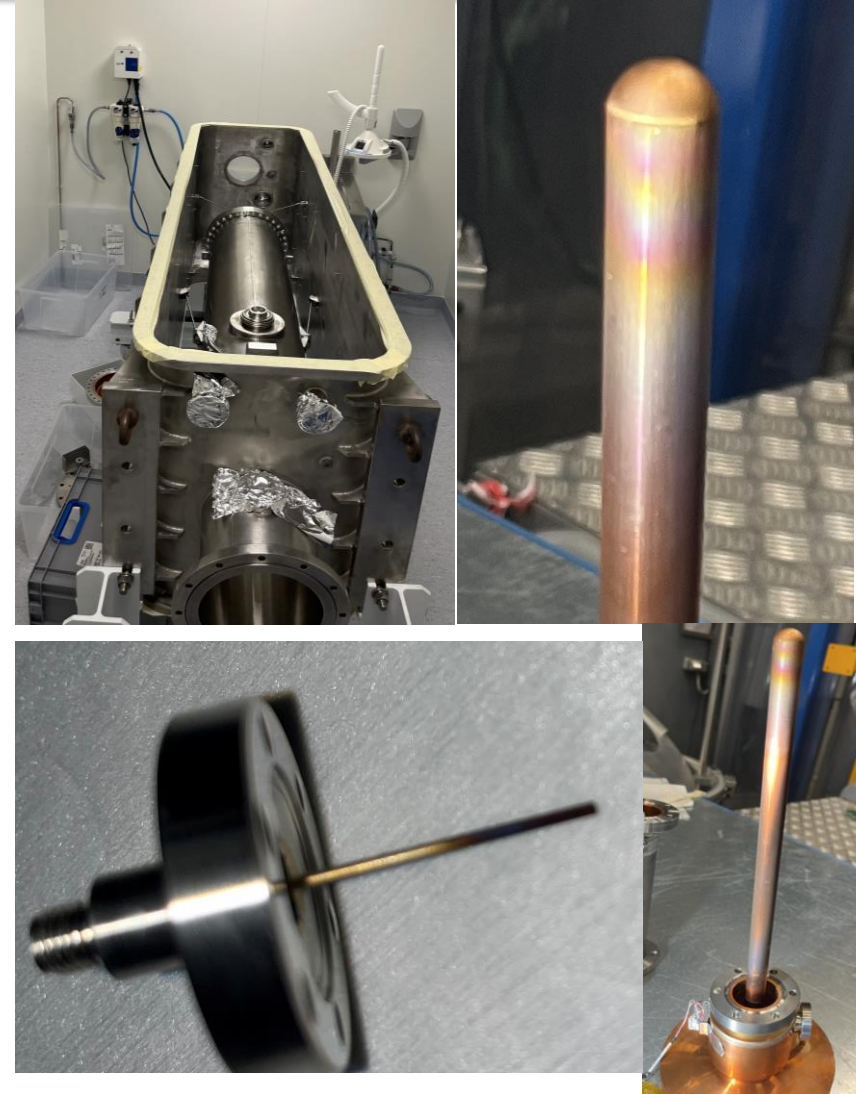

GANIL parallel operation

- Gradual increase of beam time with **parallel operation** of CYCLOTRONS and SPIRAL2.
- 2024: Fifteen days
- 2025: One month
- 2026: A month and a half.
- Priority to one machine:
 - Outside working hours -> On-call staff only attend to the priority machine.
- Development and improvement of applications
- Beam time for experiences and research/machine studies.

Beam Schedule 2026 2.0.9.xlsx											
Date	hour	C01	C02	CSS1, CSS2	CIME	SME	Aux.	TEST	LINAC source p.d	LINAC source 1/3	LINAC
Monday 1-Jun	09:00										
	10:00	Tuning ECR4		SPIRAL 1					Mise EN opération		
	14:00	129Xe23+			3S UT						
Tuesday 2-Jun	09:00				D6	T. Kusumoto					Starting
	14:00	Tuning C01			MUGAST	P1470					d1+
	18:00	129Xe23+			EXOGAM (12)	16,0 UT					LINAC Tuning
Wednesday 3-Jun	09:00				MUST2	CASIMIR					20 MeV/u
	14:00	P1397			ZDD2						
	18:00	Kulriya				ReMade					
Thursday 4-Jun	09:00					PID: 41229					
	14:00		Irradiation								
	18:00		plaques								
Friday 5-Jun	09:00										
	14:00										
	18:00										
Saturday 6-Jun	09:00										
	14:00										
	18:00										
Sunday 7-Jun	09:00										
	14:00										
	18:00										

Parallel CYCLOTRON + SPIRAL2 operation

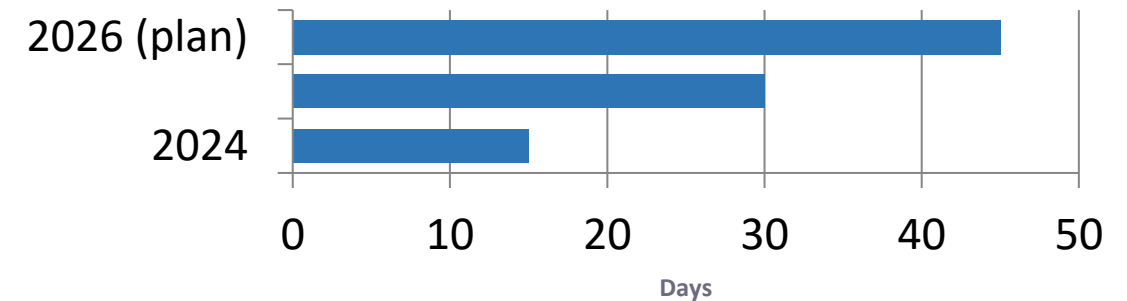

Part 3

Machine Studies

LLRF tuning, cavity compensation, pressure characterisation, BPMs and FPMs

LLRF reference phase preservation cut linac re-tuning time from 2 days to under 1 hour

Full linac re-tuning duration per campaign

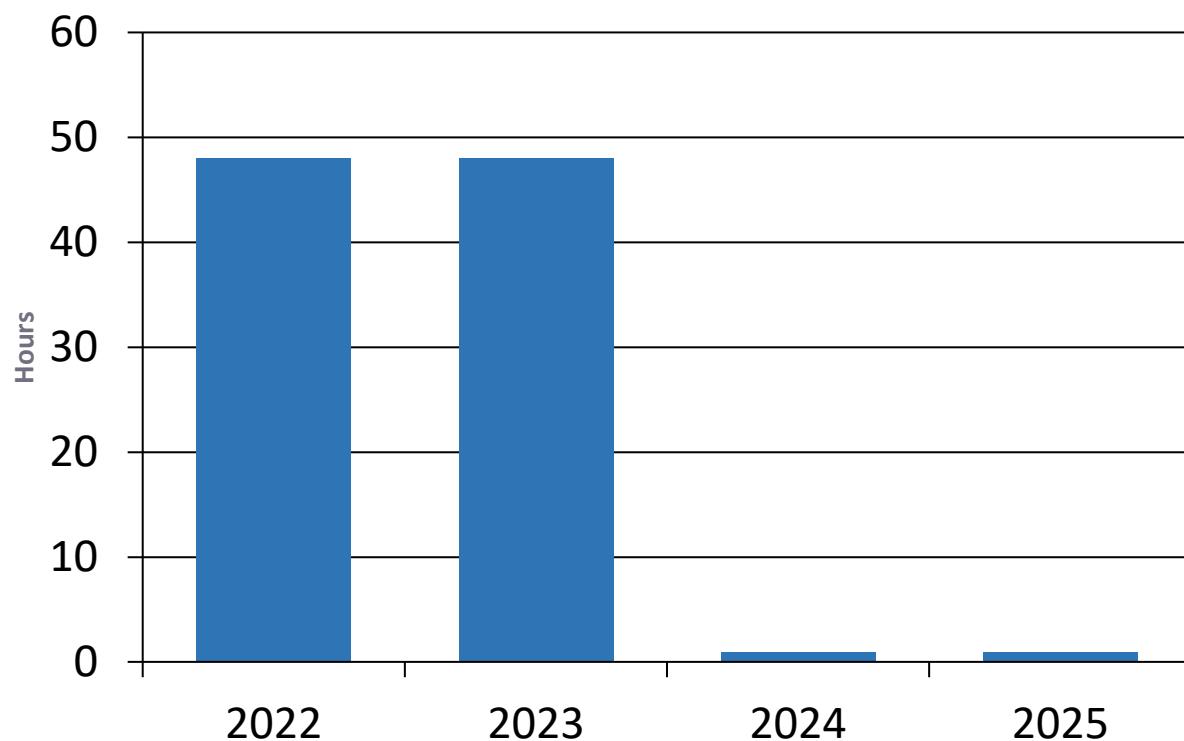

48x faster from 2024 onwards — from 2 full days to less than 1 hour

M. Di Giacomo et al., LINAC2024 · G. Normand et al., IPAC'23

Root cause (2022–2023)

Reference phases lost at start of each campaign
Full recalibration required: 29-cavity phase scans
Advanced tuning method: 1–2 days per restart
Significant physics availability loss

Solution (2024–2025)

Reference phases preserved across annual shutdown
Reference method: stored calibration reused
Re-tune time: < 1 hour for all 29 cavities
Rapid recovery after RF trips

Cavity failure compensation validated: D⁺ at nominal energy with 2 cavities missing (2025)

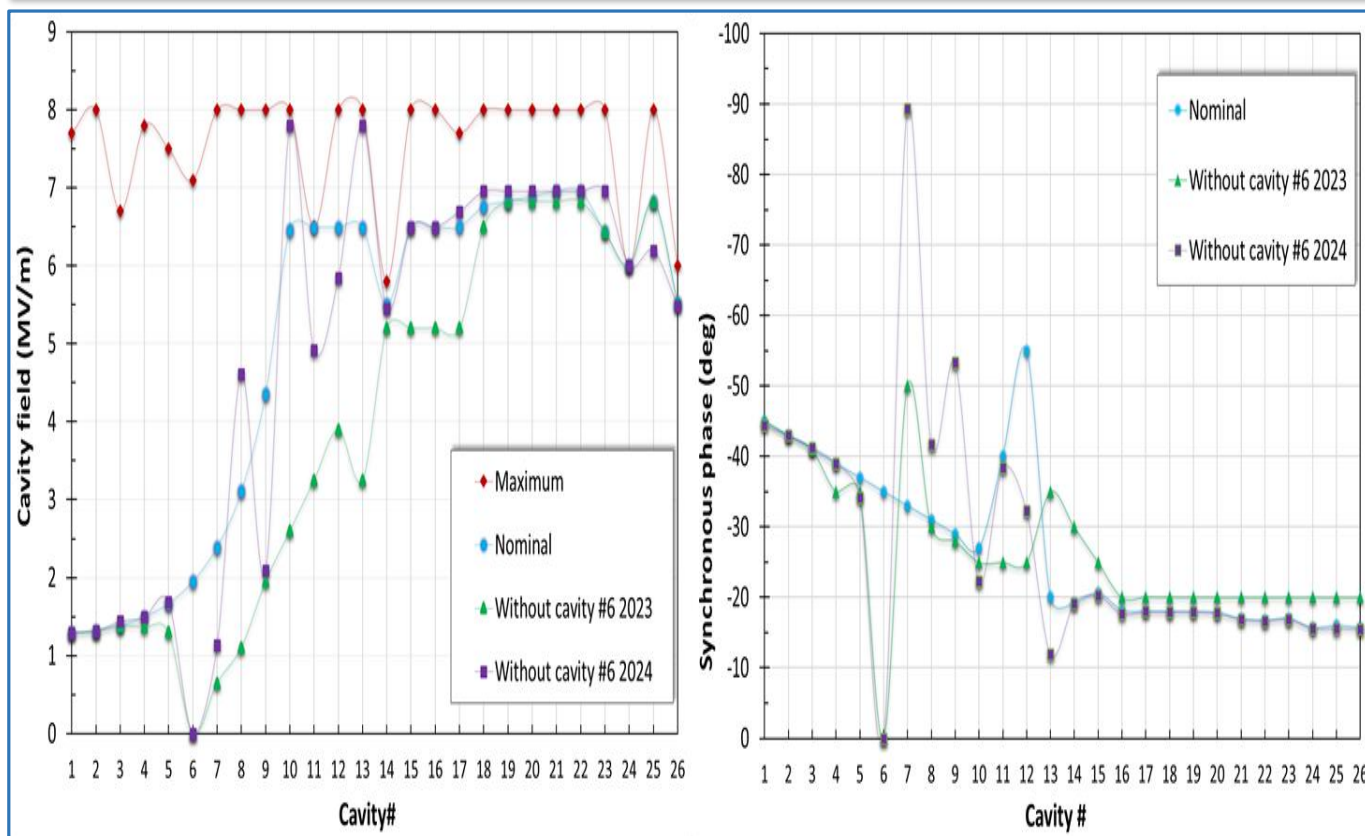

Cavity field (top) & synchronous phase (bottom): nominal vs. compensation without cavity #6

Progressive validation

2023, #6 out: D⁺ at 32 MeV — 2 kW, not nominal energy

2024, #6 out: D⁺ at 40 MeV — 2 kW, full nominal energy

2025, #1+#11 out: Nominal — no losses, 1.5 months uninterrupted

2025, #11+#12 out: Nominal — all experiments continued

Physical challenge

Low- β : large debunching at low energy — hardest case

Strategy: retune neighbours, accept slight phase acceptance reduction

Field margin: 8 MV/m available vs 6.5 MV/m nominal

SC linac pressure variation scales linearly with duty cycle — critical input for heavy-ion tuning

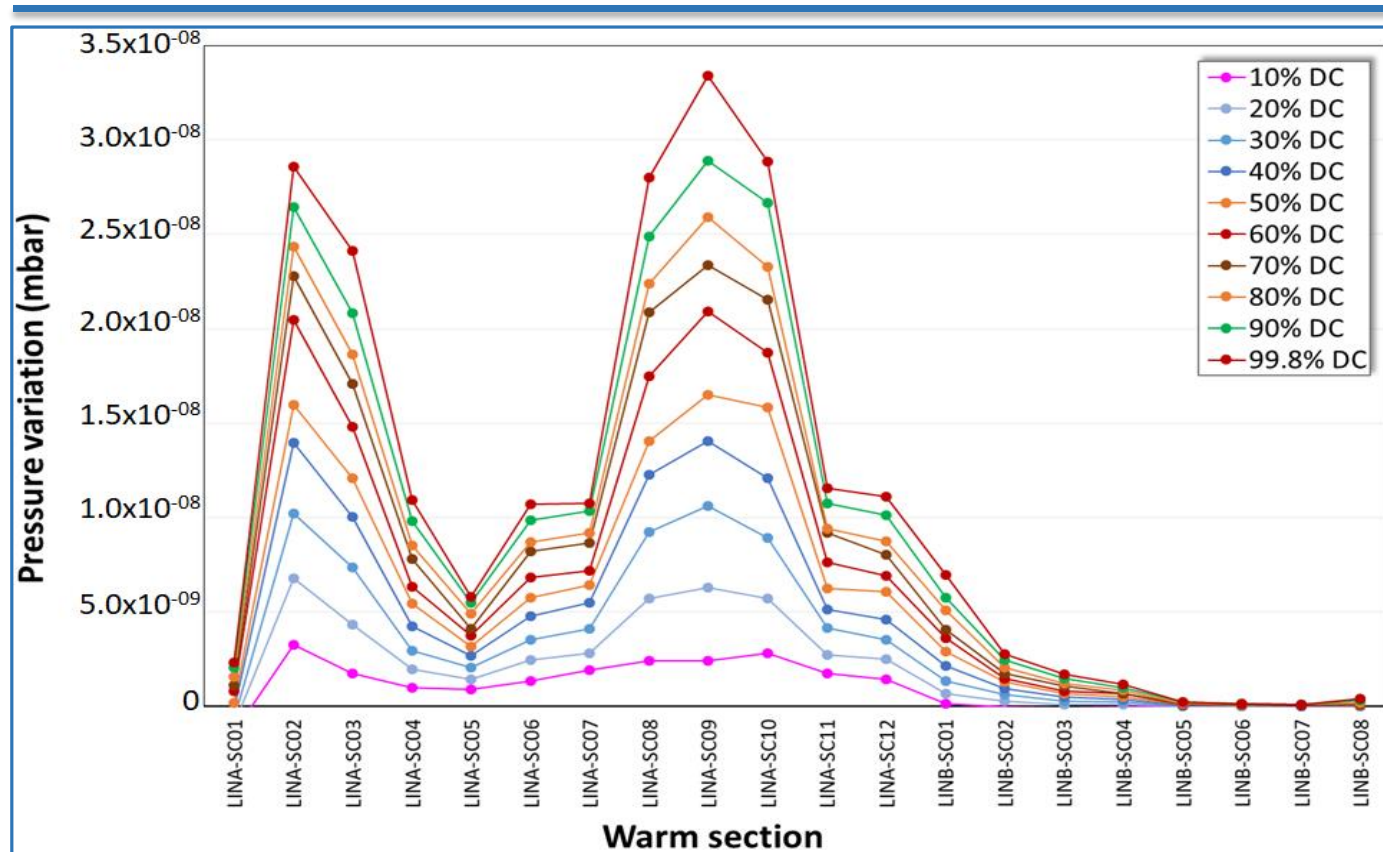

Pressure variation vs. warm section — 10% to 99.8% DC with $50 \mu\text{A } ^{18}\text{O}^{6+}$ (Source: GANIL/SPIRAL2)

Why this matters

Gas desorption from HI beams causes vacuum pressure spikes

BLMs insensitive to low-energy losses → pressure fills the gap

Critical for safe ramp-up towards Phase 2 intensities

Key findings

Highest variation in low- β section at low energy

Linear dependence on duty cycle — predictable

Peak at SC01–SC05 and SC09–SC10 warm sections

Now standard part of HI commissioning procedure

Linear scaling means safe intensity ramp-up is predictable and controllable

BPMs and Fluorescence Profile Monitors (FPMs) studies

BPMs

- Measurements for high-intensity beams (SPIRAL2 phase 2):
 - 1 -5000 μ A
- Changing requirements: Low-intensity beams
- Some improvements made:
 - Modelling of BPM signals based on the intensity, energy
 - Adaptation of the measurement chains
 - Fine calibration of gains and phases
 - Increased sensitivity at low levels
 - Reduction of RF interference
- Ongoing improvement:
 - Feasibility of measurement when using SBS (multi-harmonic)
 - Model for measuring bunch length

Mesures 2023

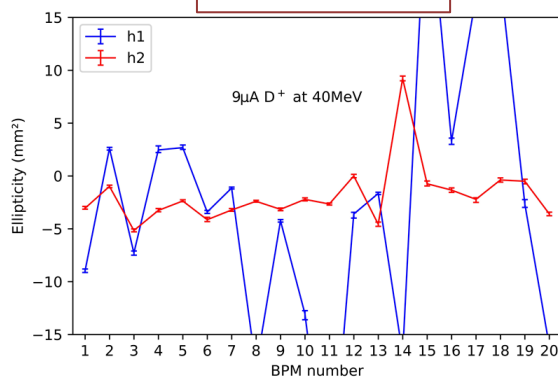

Mesures 2024

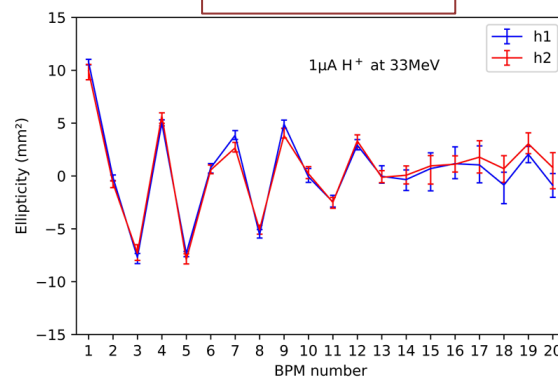

FLUORESCENCE PROFILE MONITORS (FPMs)

- LEBT: CW beam, 10 mA D⁺/H⁺ -> Restricted use of EMS
- Profile in the LEBT gas residual
- Key for LEBT beam tuning
- Second profiler to be installed in 2026

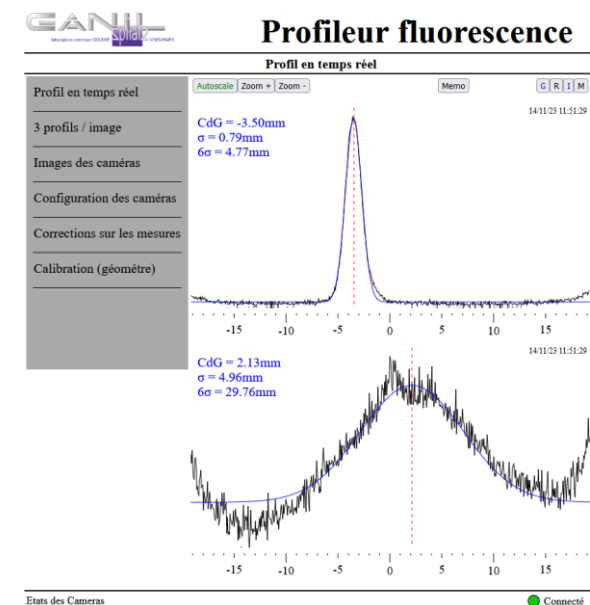

Diagnosics, electronics and instrumentation team: C. Jamet, P. Salou, S. Leroir

Part 4

Key Highlights

Heavy-ion acceleration milestones and first beam into S3

Heavy-ion programme: $^{18}\text{O}^{6+}$ at 14.5 MeV/u (2023) and $^{40}\text{Ar}^{14+}$ to S3 beam line (2024)

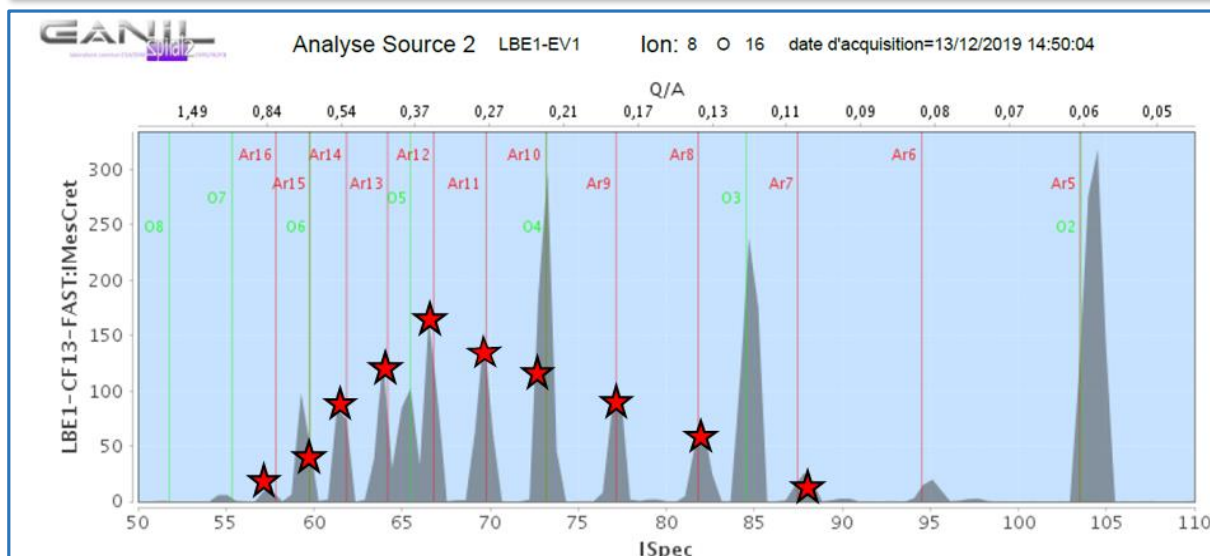

Phoenix V3 source spectrum — ^{40}Ar charge states (Source: GANIL/SPIRAL2)

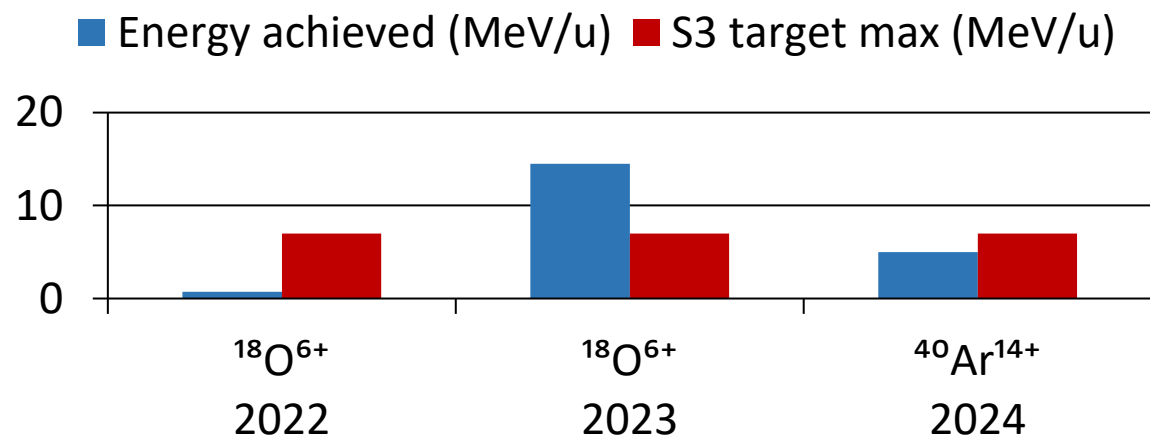

Energy milestones

2022: Low-energy comm.: 0.73 MeV/u for all HI species

2023: $^{18}\text{O}^{6+}$ at 14.5 MeV/u — nominal energy; power ramp to 2 kW

2024: $^{40}\text{Ar}^{14+}$ at 5 MeV/u sent to S3 beam line (21 Nov. 2024)

Requirement: S3 max = 7 MeV/u — linac comfortably surpasses this

All heavy-ion species now accelerated to S3 requirements — programme fully established

Phoenix V3 upgrade

$^{40}\text{Ar}^{14+}$: 100 μA , stability $\pm 5\%$ over 100 h

New capability: 1 μA for ^{48}Ca , ^{50}Cr , ^{48}Ti — key S3 beams

First $^{40}\text{Ar}^{14+}$ beam delivered to S3 on 21 November 2024 — beam matches TraceWin simulations

$^{40}\text{Ar}^{14+}$ at 5 MeV/u reached S3 Faraday cup at 18:55 on 21 November 2024 — Milestone J6A: 223 actions, 30+ GANIL staff



SPIRAL2 team celebrating first S3 beam — 21/11/2024 (Photo: GANIL)

R. Ferdinand et al., Proc. IPAC'26 (companion paper)

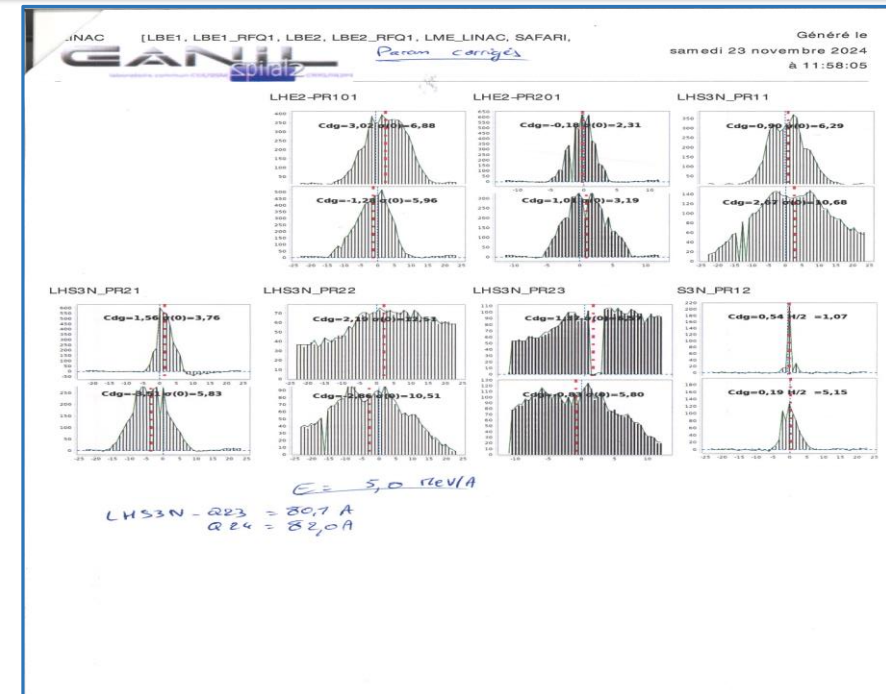

Beam profiles along LHS3N line — measured vs. TraceWin optics (23/11/2024)

Part 5

Future Perspectives

DESIR, NEWGAIN, SIMS and SAGA — expanding the science reach

DESIR building completed (Sept 2025) and NEWGAIN injector under construction

DESIR — Decay, Excitation & Storage of Radioactive Ions

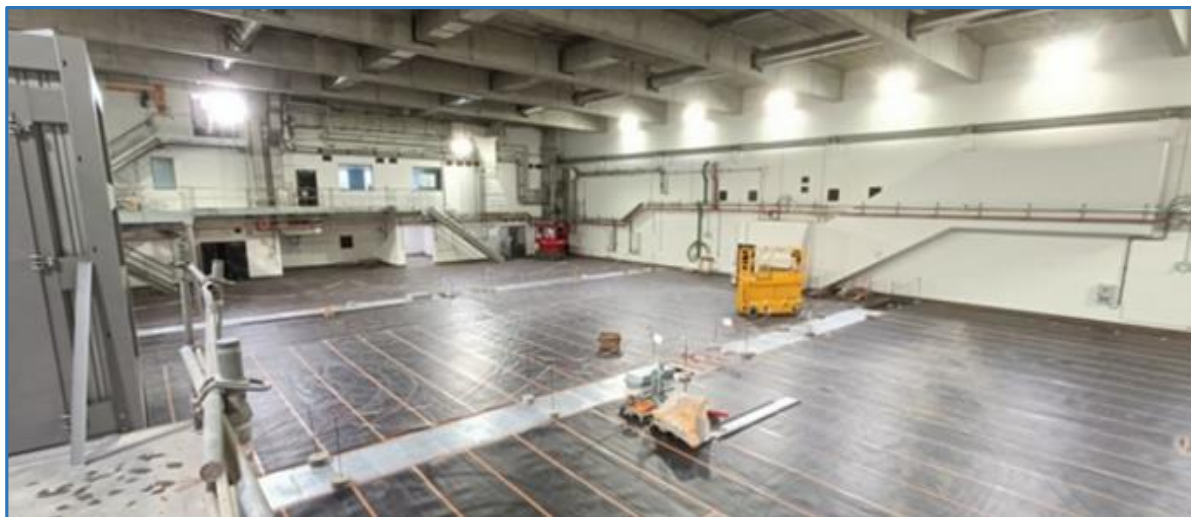

DESIR building interior — completed September 2025 (Photo: GANIL)

Low-energy facility (< few tens of keV): laser spectroscopy, ion traps

Fed by S3 separator and cyclotrons — exotic nuclei from SPIRAL2

Operating decree: March 2025 | First experiments: 2026–2027

F. Chautard et al., Proc. HIAT2025, DOI:10.18429/JACoW-HIAT2025-THY01

NEWGAIN — New Heavy-Ion Injector ($A/Q \leq 7$)

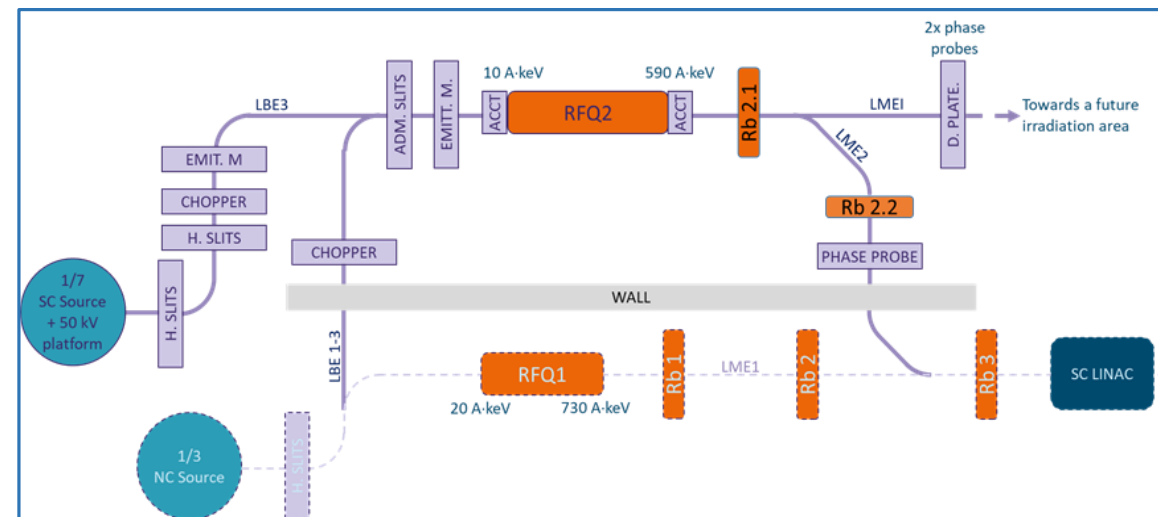

NEWGAIN layout — new SC ECR source + dual RFQ chain (Source: GANIL)

ASTERICS SC source: first superconducting ECR in France/Europe

Detailed design completed April 2023 — now in construction

Will connect to existing PHOENIX V3 — maximum flexibility

Dramatically extends heavy-ion reach of the linac

SIMS and SAGA leverage SPIRAL2 beams for medical radioisotopes and space qualification

SIMS — Multidisciplinary Irradiation Station

- Full ion beam menu (CIMAP community): H^+ , He^{2+} , C, Ar, Kr, Xe, Pb, U
 - Materials science
 - Nanostructuration
 - Astrophysics
 - Collision physics
 - Radiobiology
- **REPARE**: Research and dEveloppement for the Production of innovAtive RadioElements (:
 - **^{211}At R&D** : 28 MeV $^4He^{2+}$ on Bi target — 2 kW — cancer therapy
 - Astatine-211 first production test: 2024
- Unique: same facility for fundamental AND applied science

^{211}At is one of the most promising isotopes for targeted alpha therapy — GANIL is uniquely positioned

SAGA — Space Applications at GANIL

- Propose solutions to provide GANIL beams for spatial applications
- **SAGA applications**: Among the requests expressed by space industry, neutron beam is identified to test equipments under neutron irradiation.
- New target and setup insertion
 - Design and construction of a beryllium proton/neutron converter target.
 - Integration into the industrial setup (0° and 90°)
- Development of a setup in collaboration with Nucléides
- R&D phase: neutron dosimetry setup -> Installation of fibres for gamma/neutron measurements

Conclusions

- 1 Four years of reliable beam delivery**
25 physics experiments, 10 machine studies — D⁺ NFS with up to 50% physics beam time.
- 2 LLRF improvement: 48× faster re-tuning**
Reference phase preservation from 2024 — from 2 days to < 1 hour.
- 3 Heavy-ion programme fully established**
¹⁸O⁶⁺ at 14.5 MeV/u (2023) and first ⁴⁰Ar¹⁴⁺ beam into S3 on 21 November 2024.
- 4 Operational resilience demonstrated**
Cavity failure compensation: uninterrupted ops with 2 cavities missing in 2025.
- 5 Ambitious future programme**
DESIR (2026), NEWGAIN (A/Q≤7), SIMS (medical isotopes), SAGA (space qualification).

Omar Kamalou | omar.kamalou@ganil.fr | GANIL/SPIRAL2 — Caen, France

Thank you for your attention!

