

# Development and commissioning of normal conducting ion linacs

The INFN experience (LNL, To, PD, Na, Bo)

**SPEAKER: FRANCESCO GRESPAN – INFN LNL**

# INFN experiences in NC Linacs

## Development sequence and project stages

**Beam physics design:** tools and philosophy (losses, space charge, equipartitioning, voltage law, M.L. approach)

**RF design:** tools and philosophy (2D design, stabilization, 3D design check, tuning margins, active tuning method)

**Technology and Mechanics** (machining, bulk-CU, Cu-plating, brazing, EBW, gaskets and vacuum, QA/QC)

### **Power couplers and windows**

**Assembly, alignment, integration and transport** (tolerances, assembly sequence, transport partially or fully assembled)

**Beam commissioning** (beam commissioning steps, matching from LEBT and from MEBT, beam loading)

**ESS DTL (Lund):** Commissioned at nominal parameters. Delivered.

**IFMIF/Lipac RFQ (Japan):** Commissioned with beam up to 9%, toward CW operation

**SPES RFQ (LNL):** tuned, installed inline

**ANTHEM RFQ (Caserta):** tuned, under assembly. High power RF proved in one segment.

**IFMIF/DONES RFQ (Granada):** funded, design phase

**$\alpha$ -DTL:** design study

**ICONE DTL:** design study

# Projects overview

## ESS, SPES

Main Normal Conducting ESS Accelerator component:

- 5 DTL tanks, 3.6 to 90 MeV, 40 m, 352 MHz, 62.5 mA, pulsed @ 14Hz, 3.2 ms
- Output Beam Power: 225 kW (5.625 MW peak)
- FoDo Lattice with Permanent Quadrupole Magnets (PMQ)
- Beam Position Monitors and Dipole correctors in empty Drift Tubes

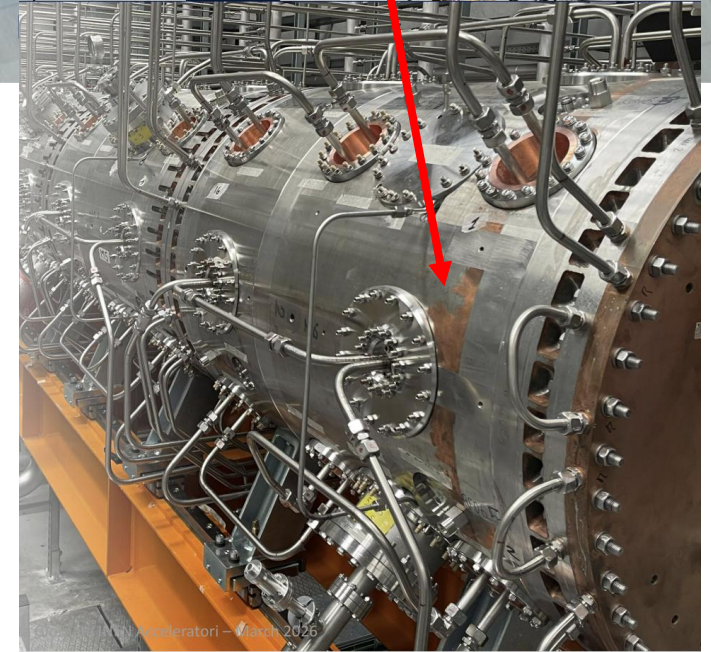
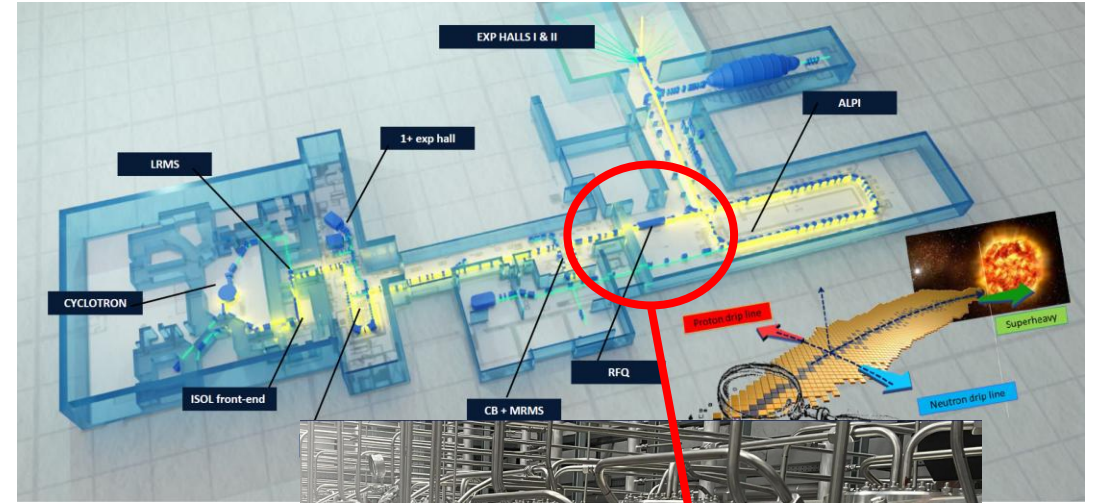
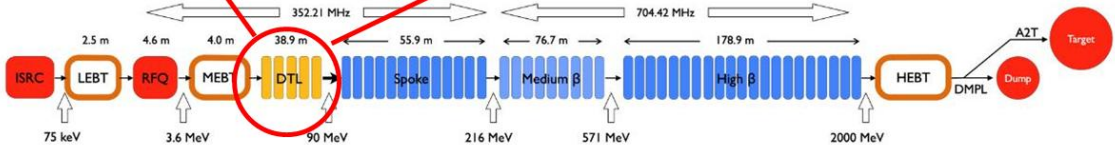
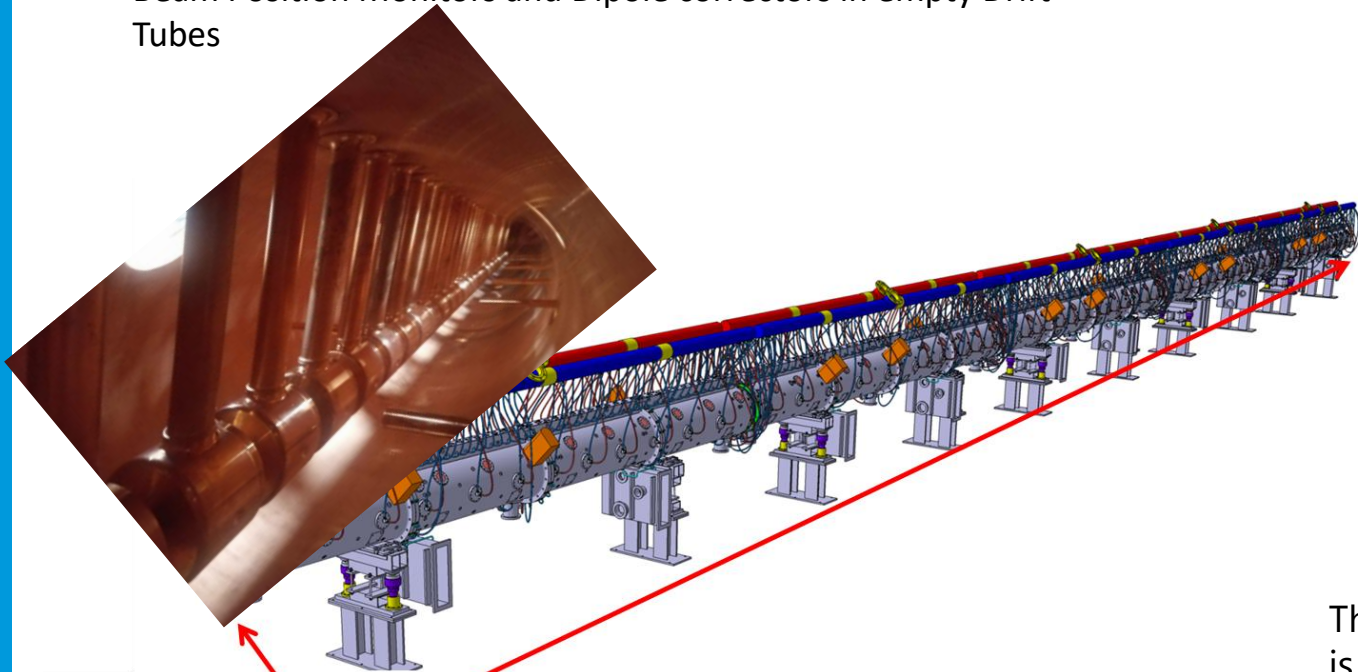

The SPES project at LNL – Selective Production of Exotic Species – is an accelerator facility for research activity in different fields using radioactive ion beams. After the RIB selection process, the reacceleration start with a **CW RFQ 80 MHz, 7 m, 0.1 mA up to 727 keV/u, A/q<7**

# Project overview

## ANTHEM, IFMIF-Lipac

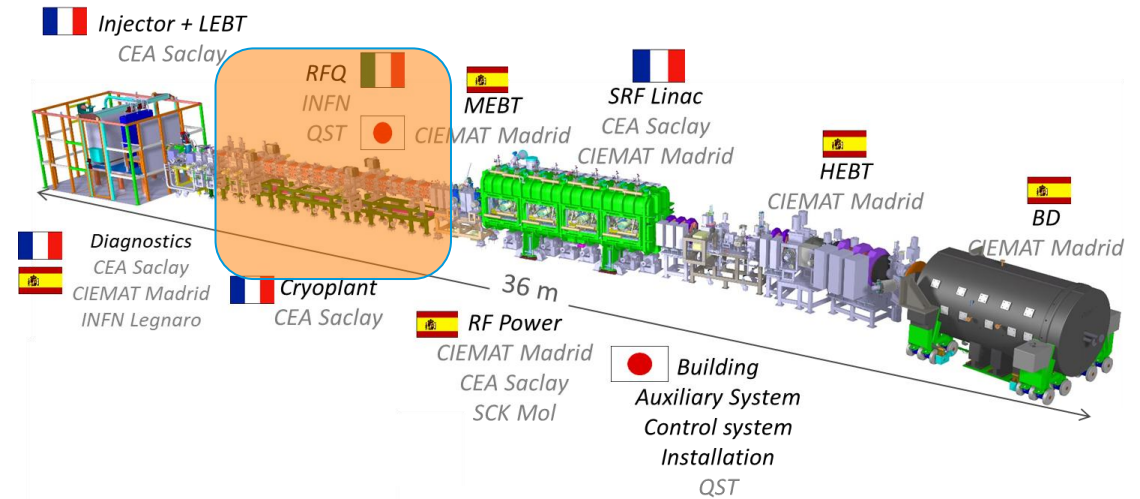
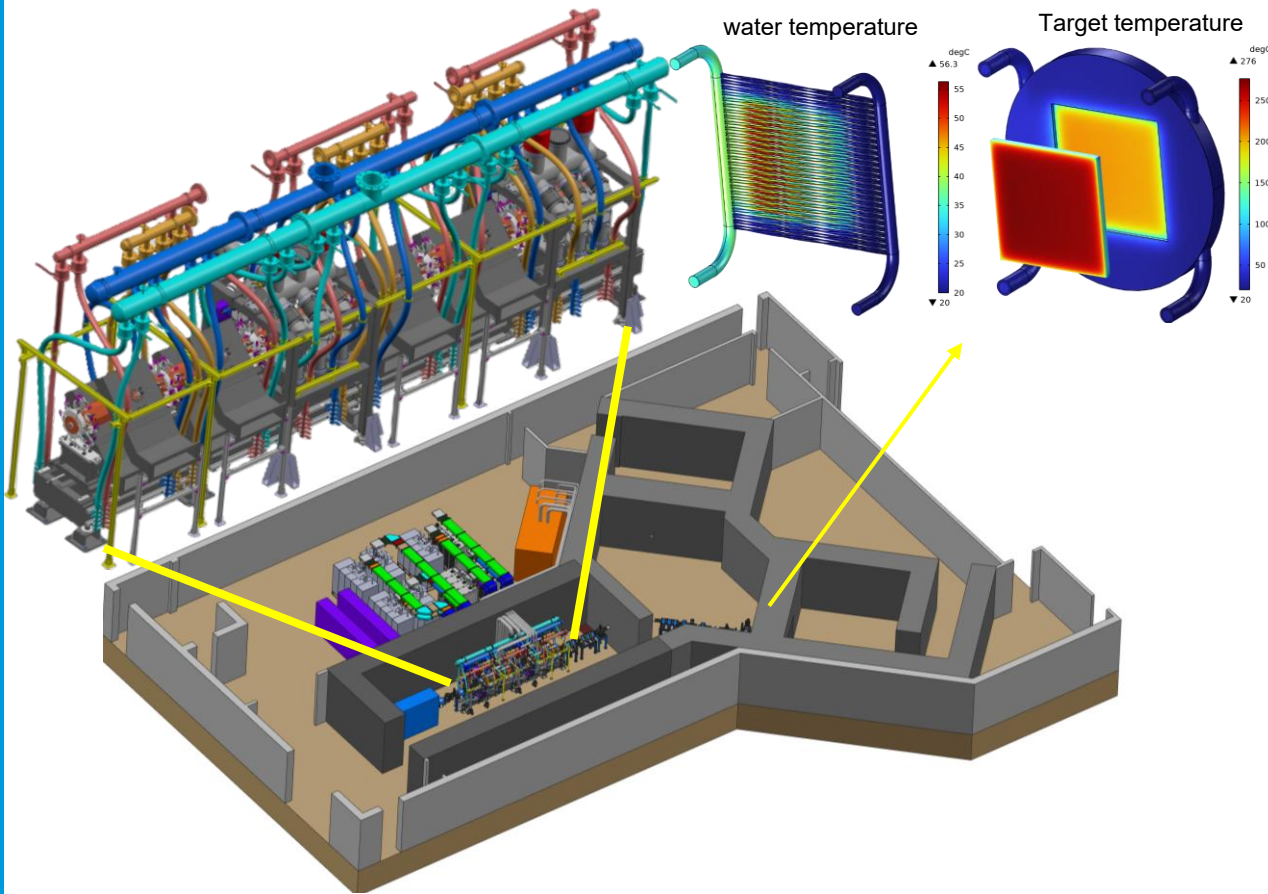

Conceived during the development of the TRASCO CW linac (1 GeV), the **CW RFQ at 352 MHz, 30 mA CW, 5 MeV** now earmarked for ANTHEM-BNCT facility, being the proton driver for a 150-kW Be neutron target.

Engineering demonstrator of the IFMIF accelerator. Rokkasho.  
**CW RFQ 175 MHz, 9.8 m, 130 mA, 5 MeV, D+**

### TRASCO-ANTHEM RFQ

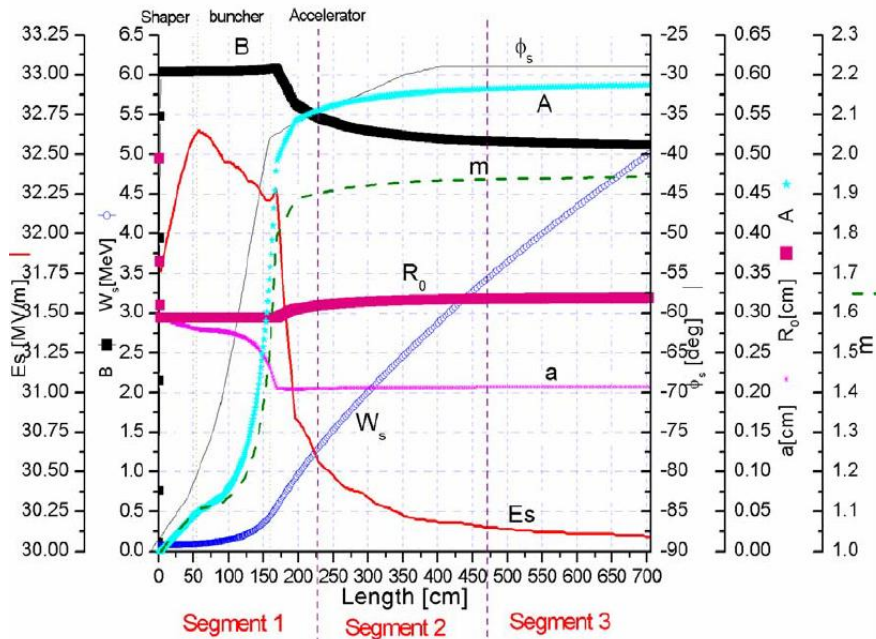

Designed in the early 2000's.  
 High intensity RFQ, fully compliant with **Kapchinsky design recipe for high intensity RFQ**.  
 $V(z)$ =constant voltage,  
 Variable  $R_0$  but  $\rho$ =constant (2D machining).  
 $E_s < 1.8 E_k$ . Length = 7.12 m  
 LANL suite for design.

$$\frac{\chi}{a^2} = \frac{1 - A_{10} I_0 (ka)}{a^2} = \text{const}$$

$$\frac{A_{10} \sin \phi_s}{\beta_s^2} = \text{const}$$

$$\psi(\phi_s) \beta_s \lambda = \text{const}$$

### IFMIF-Lipac RFQ

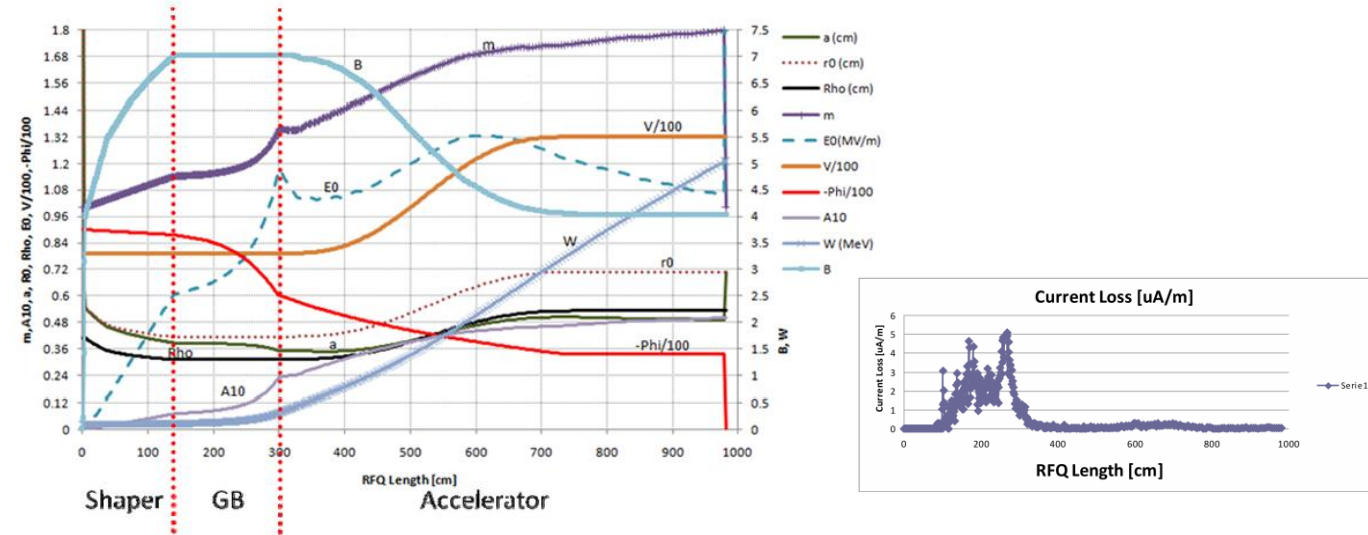

Figure 2: Main parameters evolution along the RFQ.

4-section high intensity RFQ, apply the Kapchinsky constant bunch recipe up to the bunching section.

**Voltage and  $R_0$  are given by analytical expressions**,  
 ramped to shorten the cavity.

Low B for easier LEBT matching.

$\rho/R_0=0.75$  (3D machining),  $L=9.8$  m

**Low-energy concentrated losses** to reduce structure activation.

LANL suite for design.

$$B = \frac{\lambda^2}{c^2} \frac{e}{m} \frac{\chi V}{a^2}$$

# Beam dynamics

## Tools and philosophy

### ESS DTL

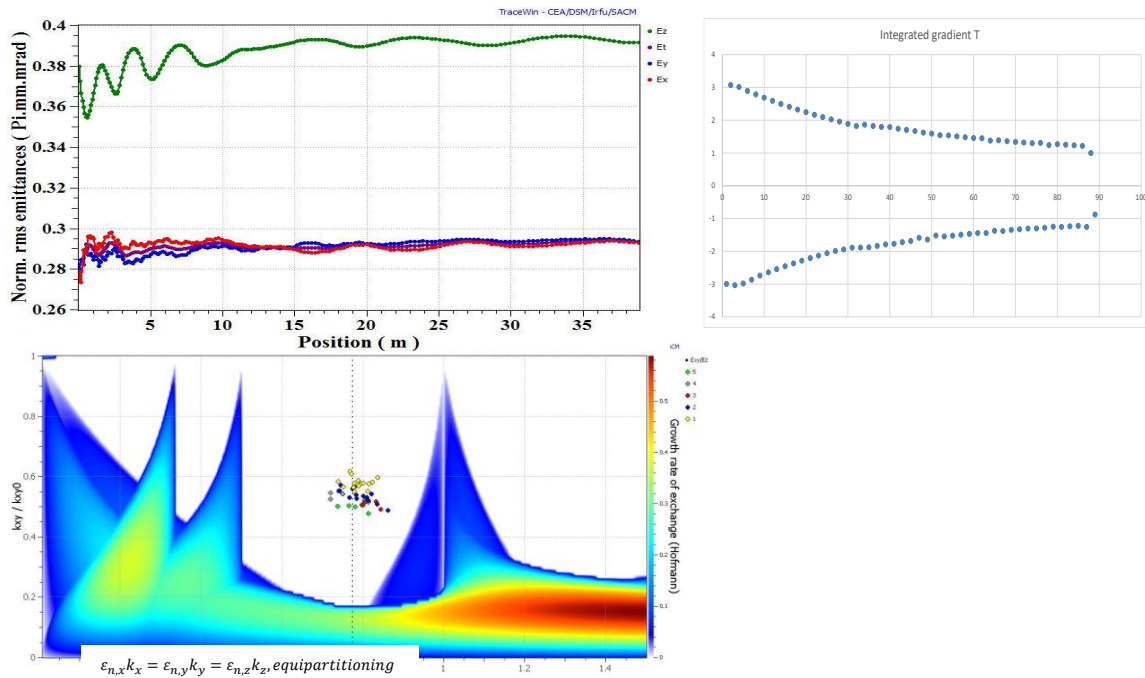

Beam dynamics **equipartitioned** to limit emittance growth.  
**DTL1 final energy higher than similar Linacs → higher beam rigidity at  $\beta\lambda$  missing-gap.**

This make easier the longitudinal matching between tanks.  
 Designed made with GenDTL CEA code suite.

### SPES RFQ

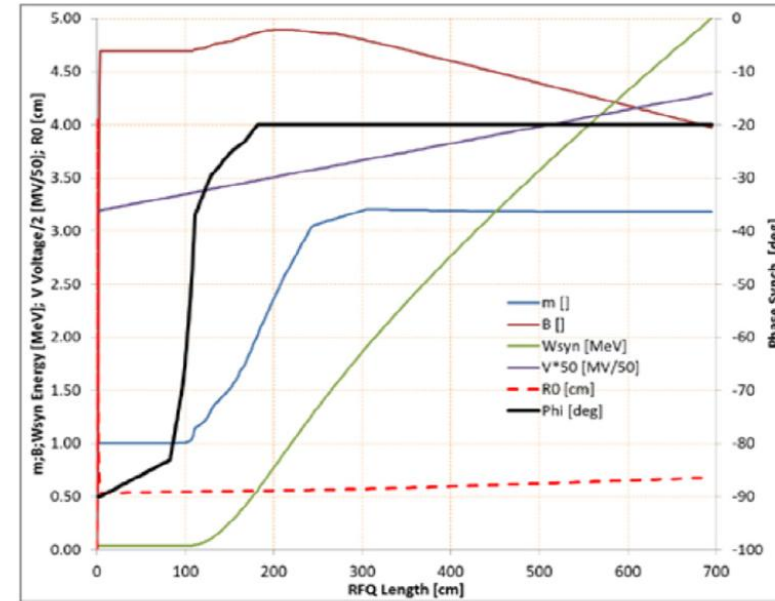

Figure 1: The main RFQ parameters vs. length.

Main goal: **Minimization of longitudinal emittance to improve ALPI Linac beam performances.**

Designed with the home-made program CORTO, developed for 6-sections low current RFQ design.

Full RFQ generation by LANL codes (PARI, PARMTEQM)

# RF design tools and philosophy

## RFQ cross section design Highlights

- $Q_0$  optimization: «round» and «square» profile for improvement of the Volume/Surface ratio
- Electrode thickness → room for Cooling channel positioning and mechanical stability during machining
- Angles and Radii constant → simplify the machining.
- Upper surfaces → designed to have room for tuners and couplers

## Accuracy budget and tuning range

- Geometric errors → perturbation  $\Delta V(z)/V(z)$  (Vane Voltage or Accelerating field) and of the global resonant frequency.
- Goal:  $|\Delta V/V| < 2-3\%$  to not jeopardize beam transmission and quality.
- Tools used to analyse the effects of perturbation include circuit and transmission line models, combined with numerical simulations
- In the first place, such errors are corrected by **tuners**. Tuning range larger than the acceptable value, the design can foresee the usage of stabilizing elements..

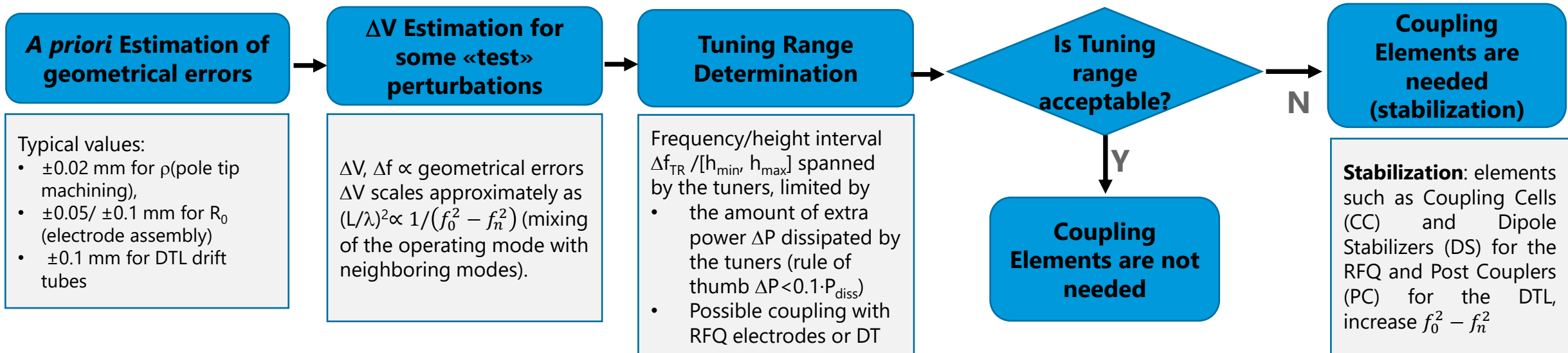

Target TE<sub>21</sub> frequency profile

$$\hat{f}(z) = f_0 - \frac{1}{2f_0} \left( \frac{c}{2\pi} \right)^2 \frac{V''(z)}{V(z)} = f_0 - \Delta f_{R_0}(z) + \Delta f_T(z)$$

Frequency shift due to R<sub>0</sub> variation

Frequency compensation by height or thickness

### TRASCO ANTHEM

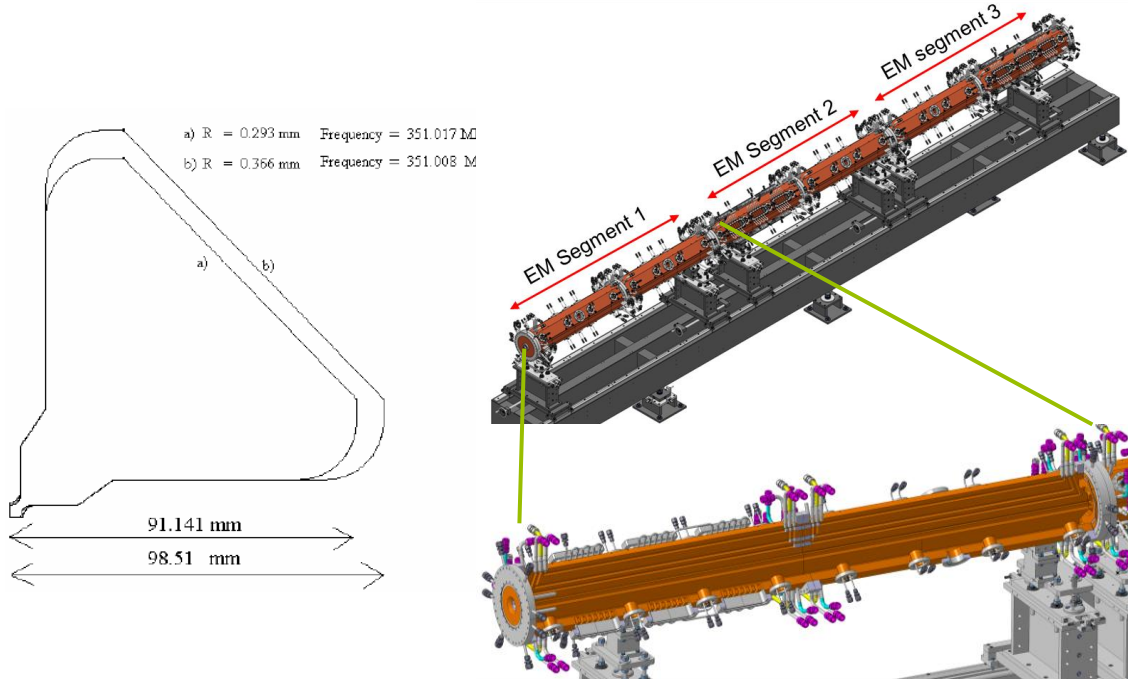

Triangular section.

R<sub>0</sub> variation recovered tuning on the triangle height.

**2 Coupling cells and Dipole Stabilizers** → LEDA experience

Active tuning with water, 3 separated circuits.

8 RF power couplers, 125 kW CW each.

### IFMIF Lipac

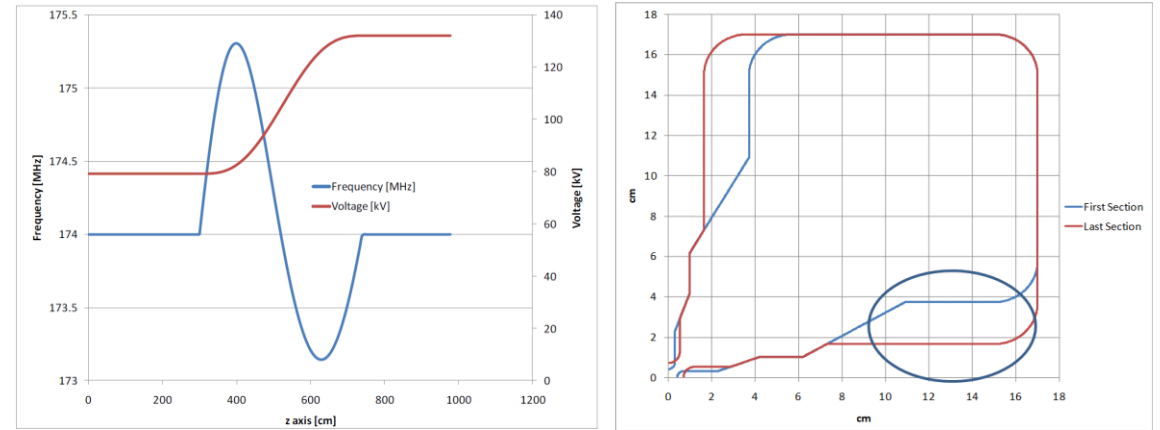

With constant Voltage = 106 kV, RFQ Length = 12.5m

Square **cross-section with tuning on the electrode's W-base** to "print" the voltage on the cavity shape.

$$h_{QQ}(z, z_0) = \frac{\delta U_q / U_q}{a_{QQ} / C_{QQ}} = \frac{1}{4} \frac{\phi_{q0}(z_0)}{\phi_{q0}(z)} \sum_{n=1}^{+\infty} \frac{\omega_0^2}{\omega_0^2 - \omega_{qn}^2} \phi_{qn}(z_0) \phi_{qn}(z)$$

Detailed **perturbation analysis** prescriptions:

- No need of stabilization.

Active tuning with in 3 independent cooling circuits, able to regulate the voltage distribution in operation

**8 independent amplifiers**, 200 kW each.

### SPES RFQ

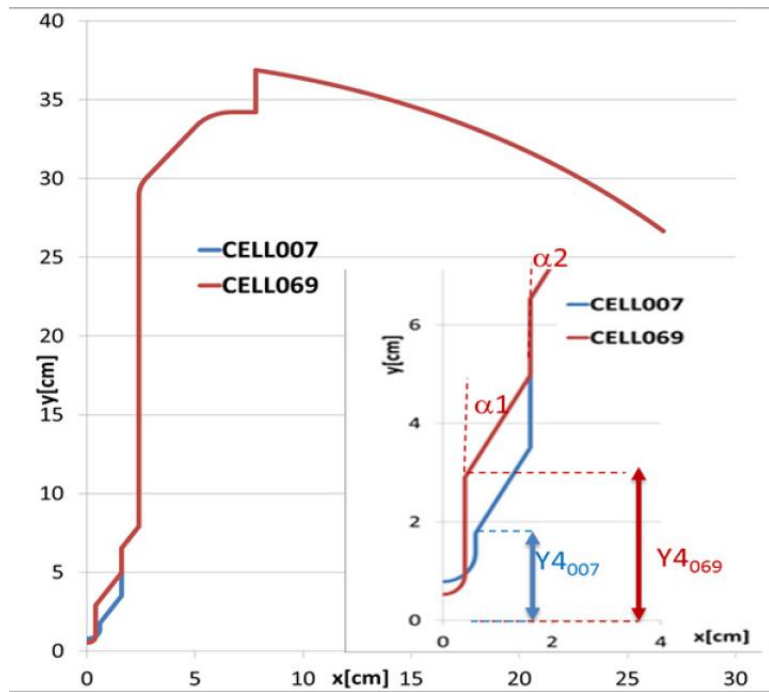

Very favorable  $L/\lambda \rightarrow$  no coupling cells  
 Capacitive compensation of  $R_0$ .  
 Linearly ramped field obtained by end cell tuning.  
 Single loop coupler 120 kW.

### ESS DTL

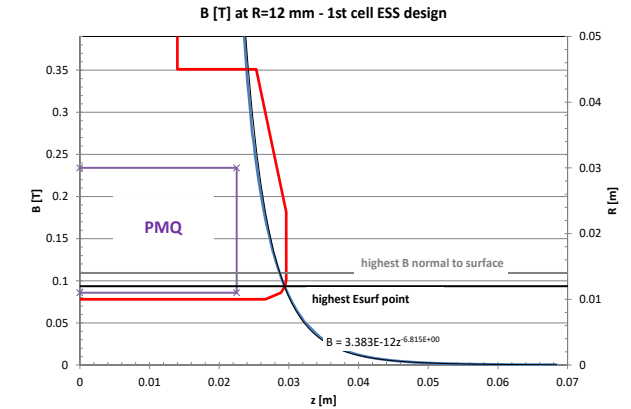
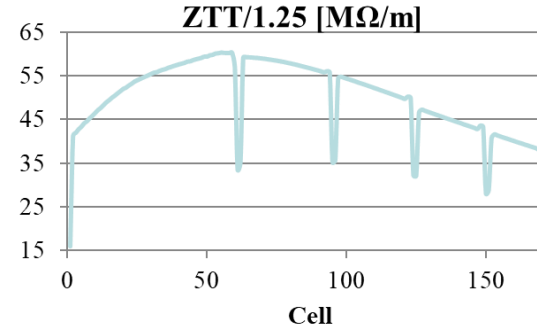

Limite the compresence of B and E field to limit sparking risk.  
 Optimization of the ZTT for high efficiency structure.  
**Post couplers distribution** evaluated with circuit model and with full 3D COMSOL simulations (no HFSS...)

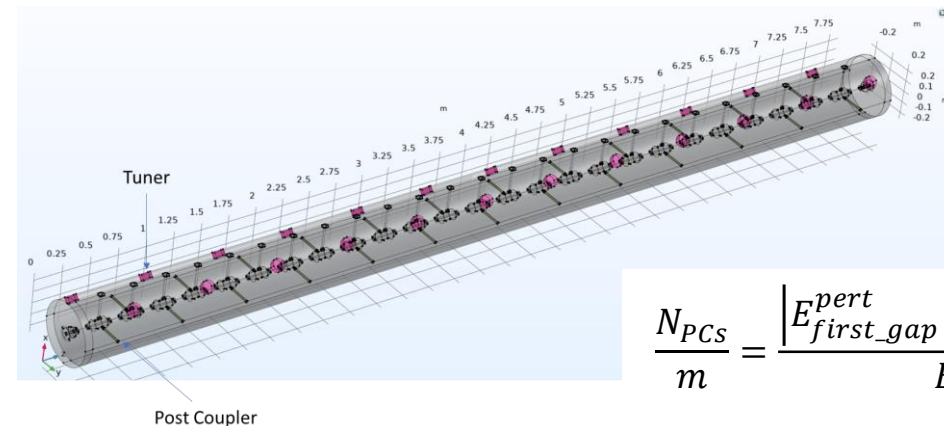

$$\frac{N_{PCs}}{m} = \frac{|E_{first\_gap}^{pert} - E_{last\_gap}^{pert}|}{E_0} \cdot \frac{1}{L_{tank}}$$

# Technology and mechanics

Cavity construction and sealing. More tools than philosophy.

## TRASCO-ANTHEM

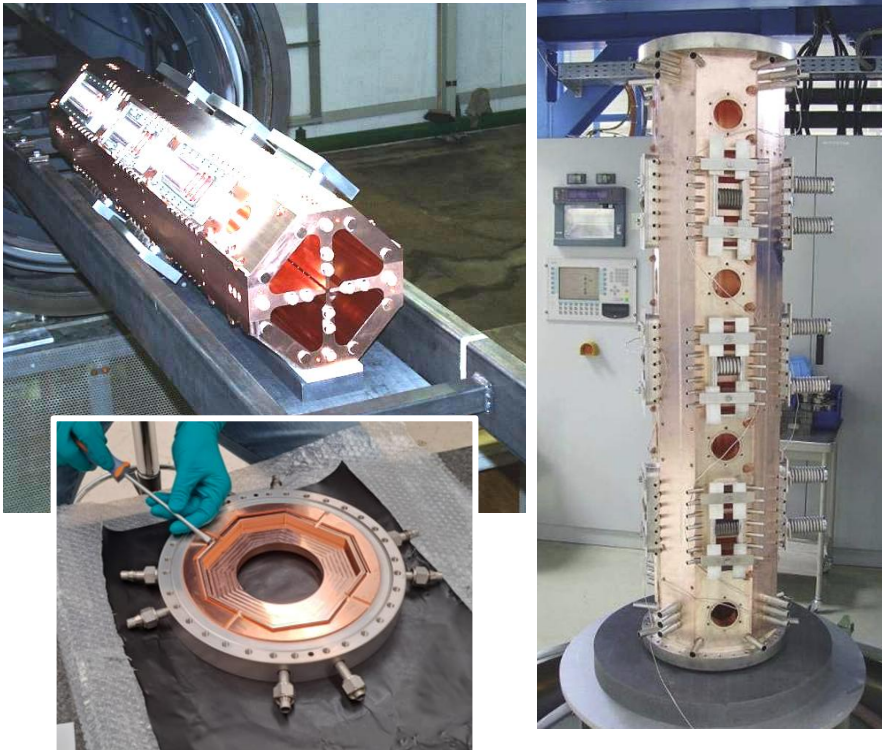

**Horizontal brazing 4 sectors + vertical brazing** for circular CF 250 flanges → issues on the 2<sup>nd</sup> brazing.  
Standard CF gaskets.  
RF contacts only in the END Plates and COUPLING plates and coupling provided by a thin brazed copper lip.

## IFMIF Lipac

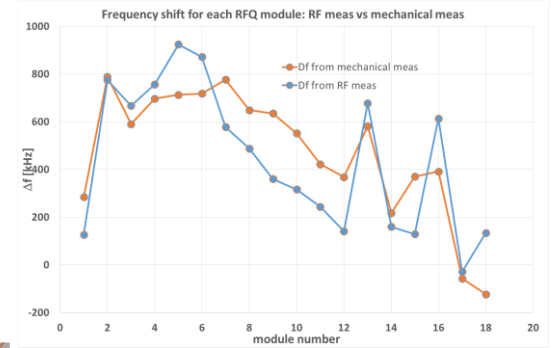
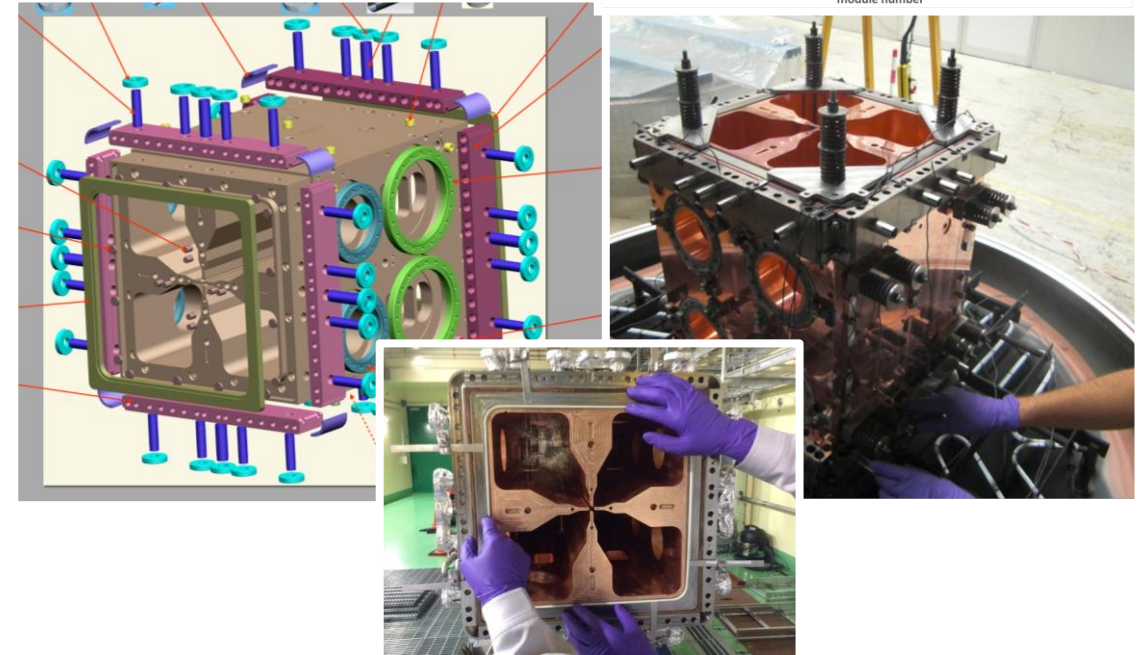

**Single brazing:** Avoid problems with circular flanges and avoid second annealing of the copper structure.  
**Decouple mechanical connection towards leak tightness.**  
Each module characterized in **CMM and VNA frequency** → good match →  $dR0 < 0.1\text{mm}$   
Helicoflex squared gasket.

# Technology and mechanics

Cavity construction and sealing. More tools than philosophy.

ESS DTL

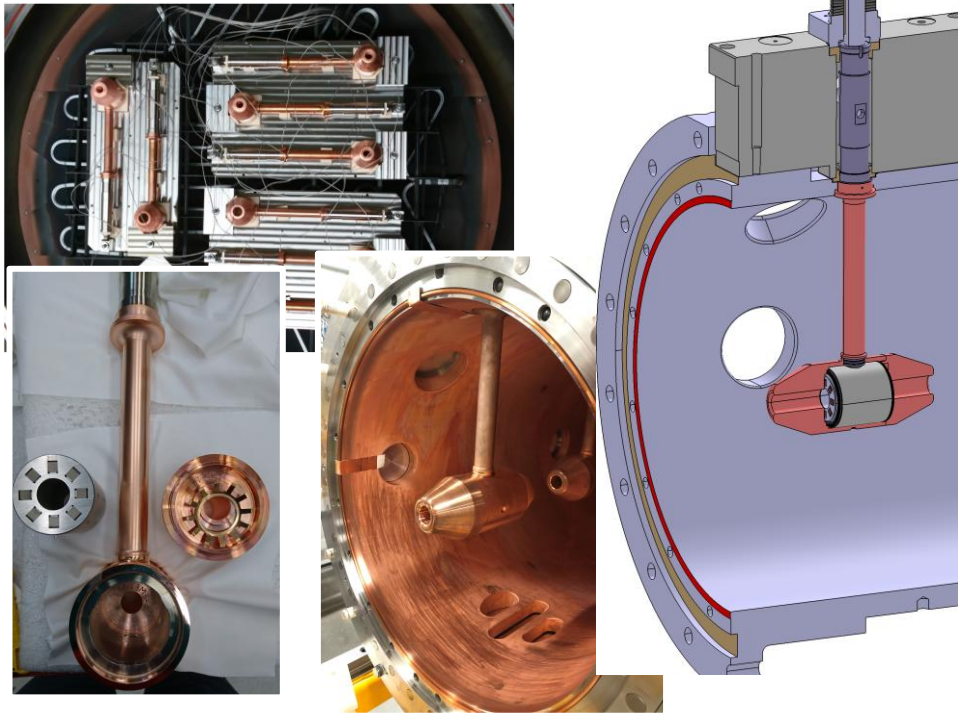

SPES RFQ

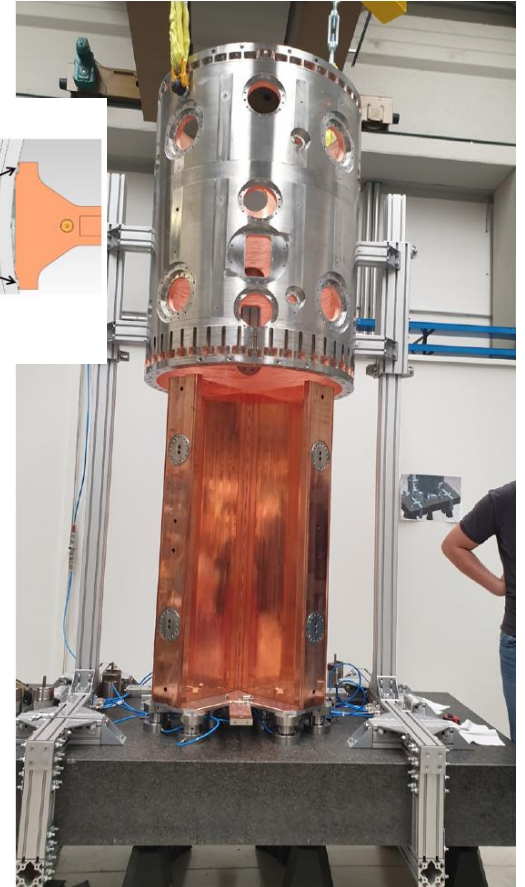
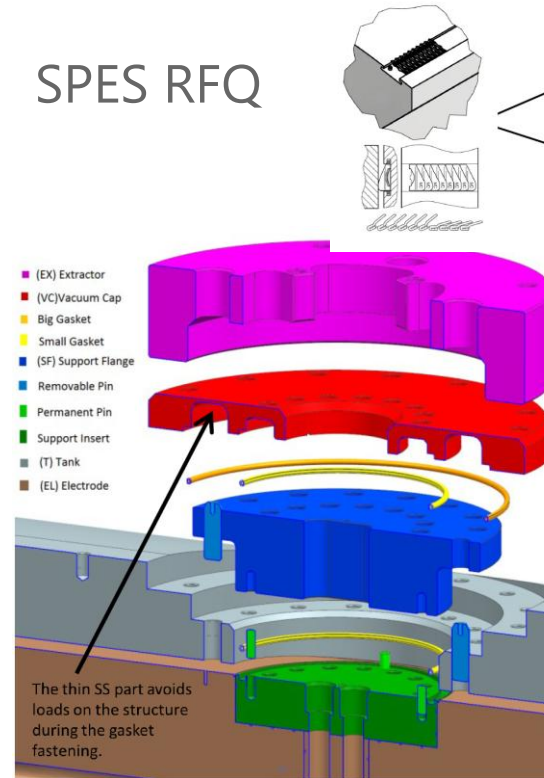

Derived from Linac4. **4 mechanical modules holding the drift tubes.**  
**Copper-plated tank** has RF and structural functions.  
**Precision** lies in **the drift tubes machining** and **aluminum girder positioning**  
 Traditional external end flange of the module.  
 Internal production and brazing of the DT body.  
 Helicoflex housing between the modules → **cleaned from cu-plating, surface polishing to reach proper roughness.**

Application of the DTL concept to a large section RFQ:

- **SS cu-plated tank** is the master providing stiffness, vacuum an RF envelope;
  - **Electrodes** are equivalent to DTs. The modulation is machined after brazing the top electrode flanges.
  - The **positioning flange (blue)** is the equivalent of the girder; it is finished after metrology of electrodes and tank.
- RF contacts are placed between tanks and electrodes to cut RF currents.  
 All **helicoflex surfaces** are cleaned up from cu-plating. CMM and RF check after the vertical assembly.

# Assembly, alignment, transport

## Only tools?

**Needs:** Alignment of the modules; Accessibility for testing a tuning; Trasport to the final site of the facility; Integration in the facility

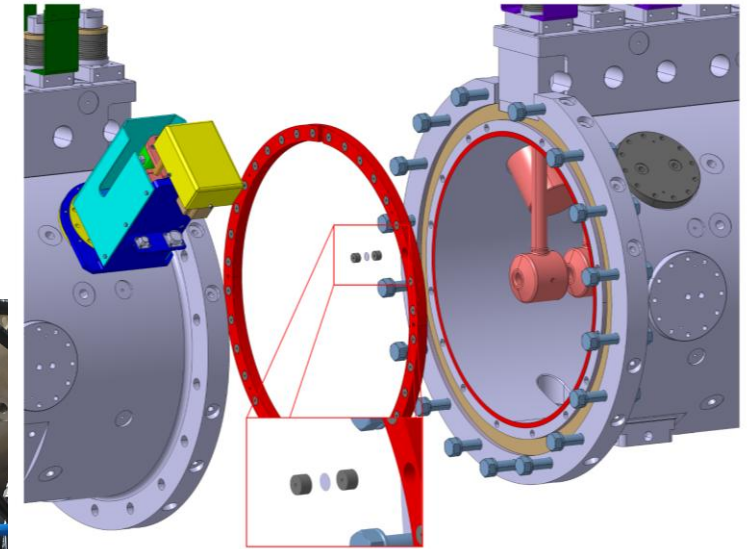
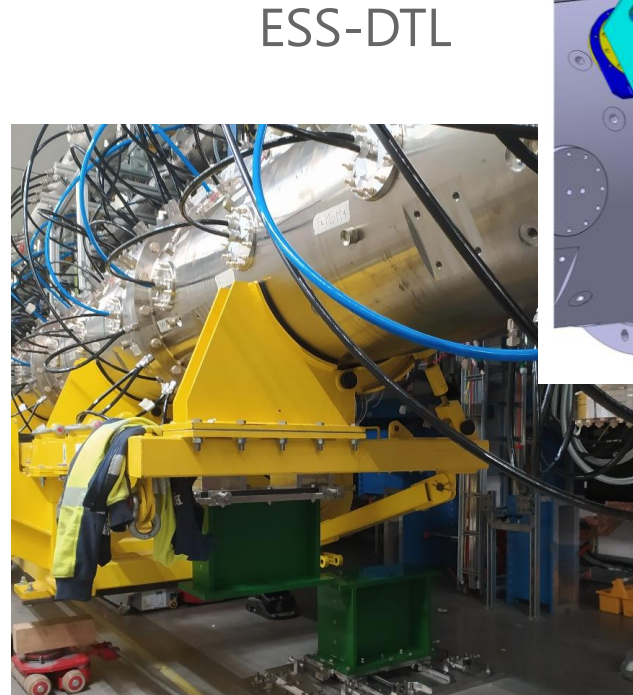

Pre-Assembly of **3 super-modules shipped to Japan**.  
The **entire cavity was assembled for the first time in situ**.  
**Shims** were **machined** for longitudinal positioning of the modules → leak test, tuning, cooling system.

Alignment of the 4 modules composing tank ensure all PMQs centers  $< 0.1$  mm from the best axis fit.

Module by module adjusted using a **coupling ring and calibrated shims**. No rework is required during the assembly phase.

Tank transported **already tuned, vacuum tested and cooling tight**.

Dedicated trolley for transport. Once in position, the tank is transferred to the final supports.

# Assembly, alignment, transport

Only tools?

SPES RFQ

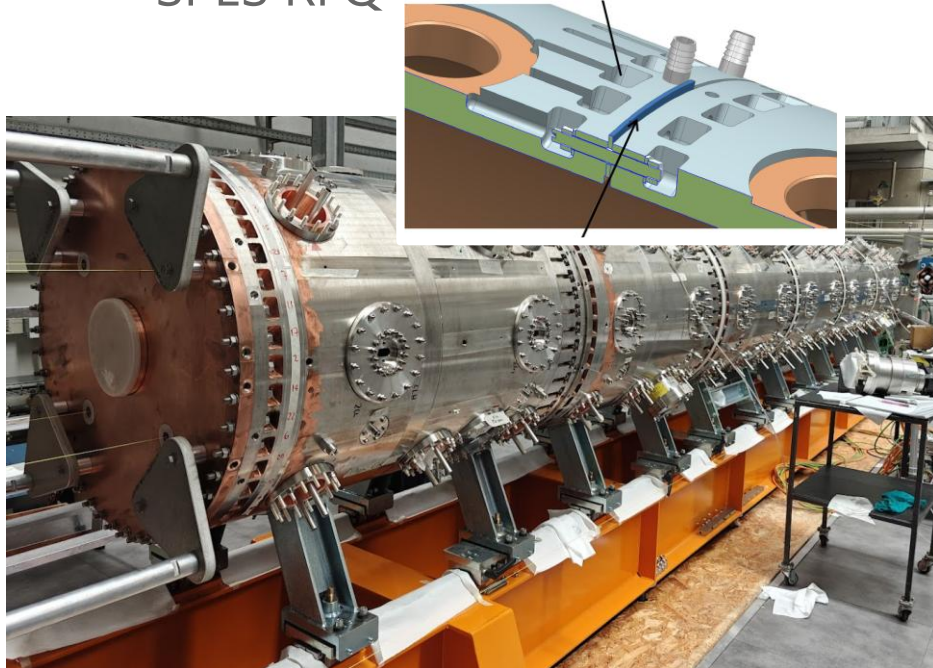

TRASCO-ANTHEM

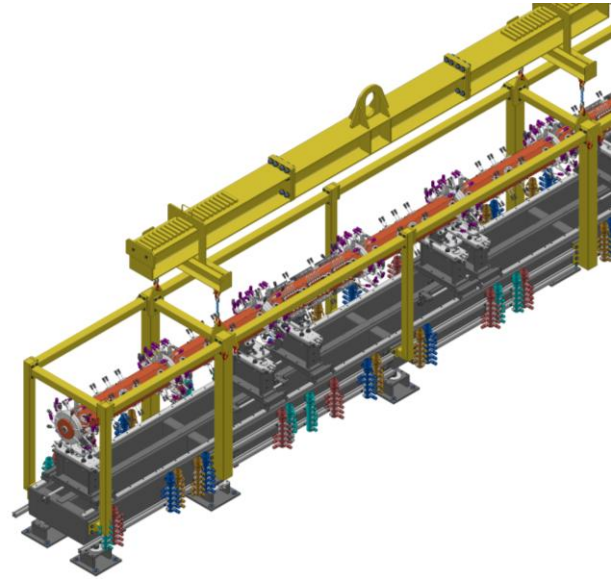

No transport of the entire cavity.  
 Each module is assembled inline on the support and aligned.  
**Machined shims** are bolted on the module front face to obtain a correct relative positioning  
 The full cavity and the input **solenoid** share the same isostatic support for common alignment at the input beam matching.

Final assembly **reviewed on the experiences of IFMIF+ESS+SPES:**  
 Modules transversally coupled 2-by-2 with laser tracker (originally alignment pins were considered).

Final support studied for:

- Assembly and disassembly of the RFQ
- Tuning of the RFQ
- Shipment of fully assembled and tested RFQ
- Isostatic alignment in situ, including **solenoid**.

# Beam commissioning

## Space charge and beam loading.

### IFMIF-Lipac

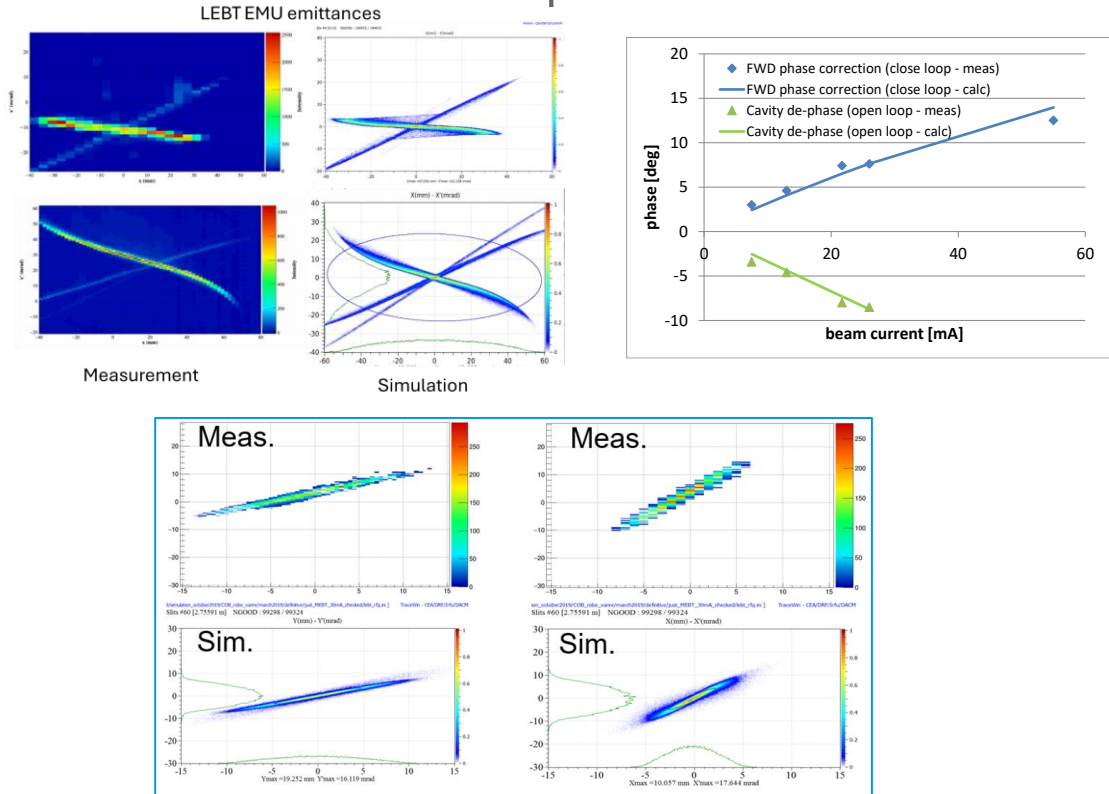

RFQ Beam commissioning prepared by an intensive study of the **LEBT matching conditions**, benchmarked with simulations and advance space charge models.

**Verified RFQ output emittance**, Transmission curve and beam loading model of the beam's reactive power.

### ESS-DTL

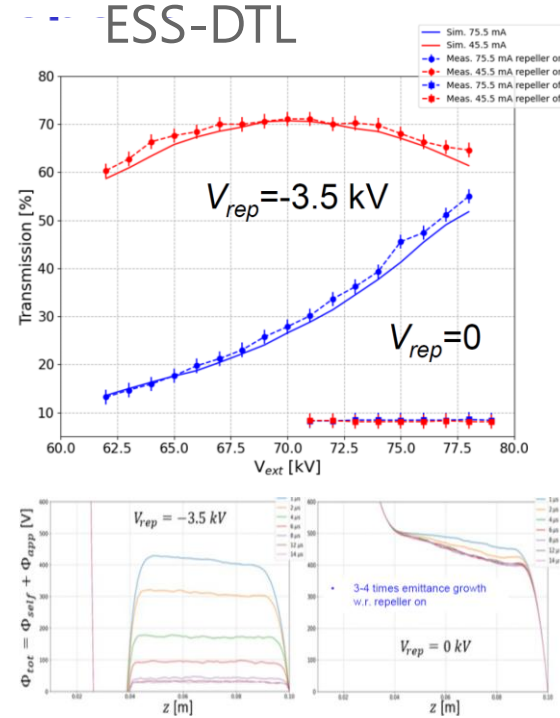

### DTL long acceptance

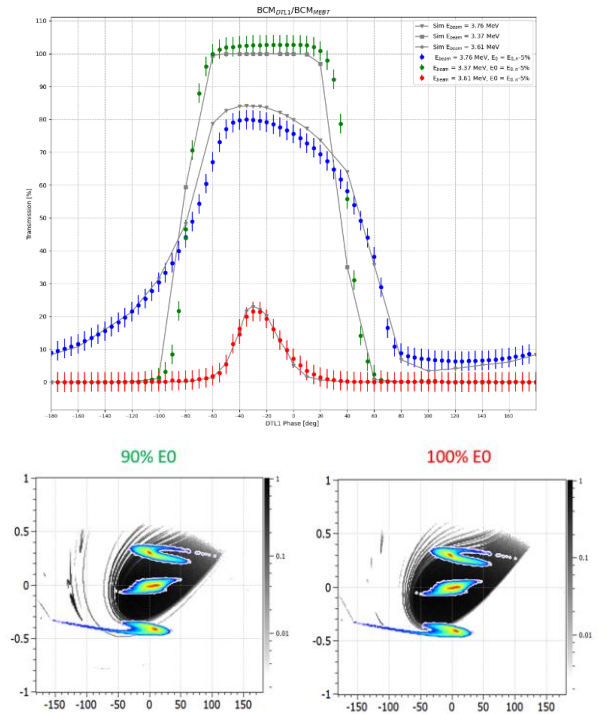

**IFMIF LEBT experience and models applied to identify ESS-ISRC emittance issue** (disconnected repeller) by measuring beam divergence in the LEBT. As-built model used to measure **DTL longitudinal acceptance** and benchmark E0 calibration.

# High power couplers and windows

## 100 kW class RF windows: Multipacting free-design and testing protocols

**ESS DTL:** 2 iris couplers/tank. WG-Disk-windows.  
1.4MW peak, 70 kW aver.  
Multipacting. Refurbished and reconditioned  $< 10^{-7}$  mbar.

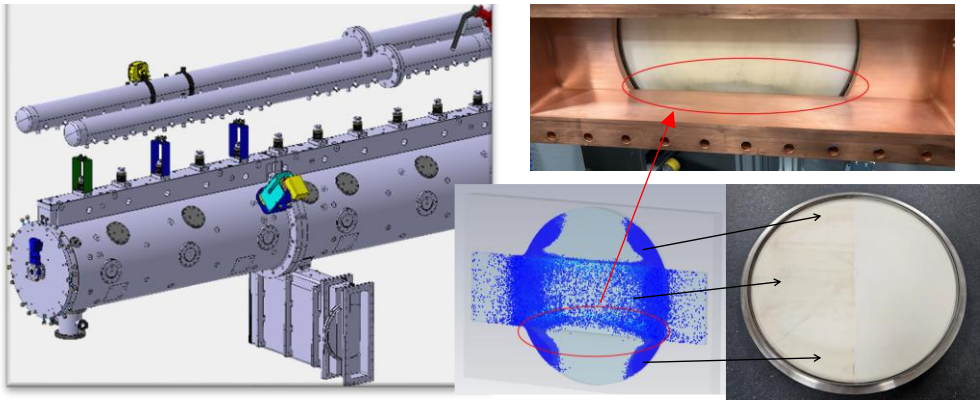

**ATHEM RFQ:** 8 cylindrical windows on loop couplers. 125 kW CW.  
No multipacting. Conditioned in test cavity  $< 10^{-7}$  mbar.

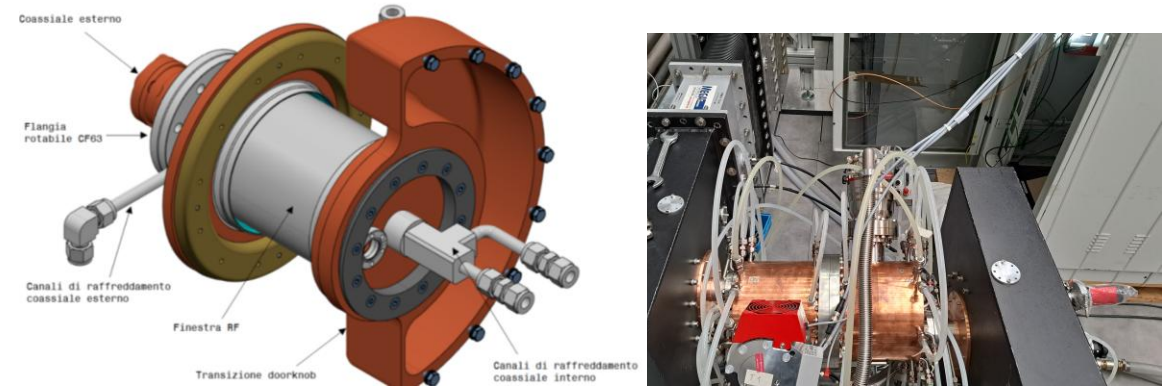

**Redesign:** multipacting free  $> 70$  kW. Cooled coaxial window brazing sealed. Prototypes in production.

**IFMIF and SPES RFQ:** operation starting with o-ring sealed coaxial windows.  
Strong Multipacting and overheating. 200 kW CW power level.

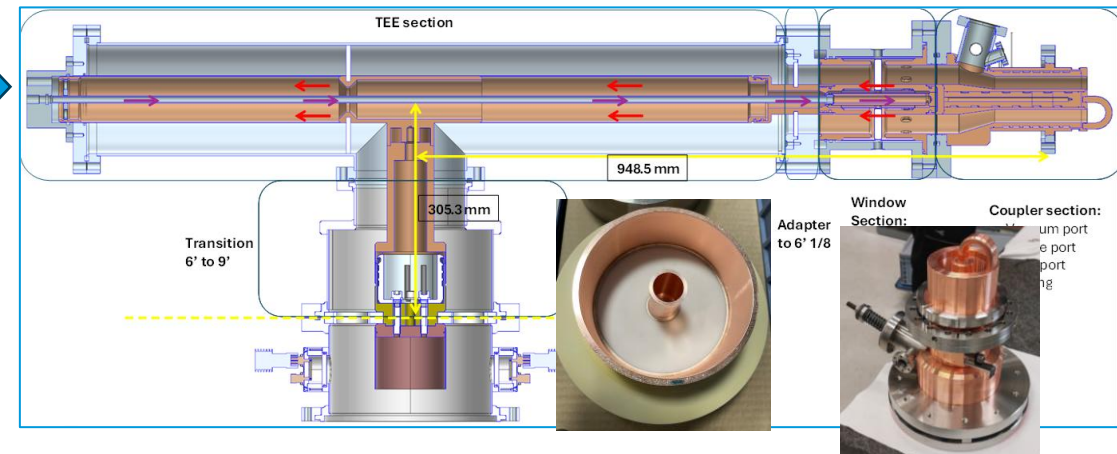
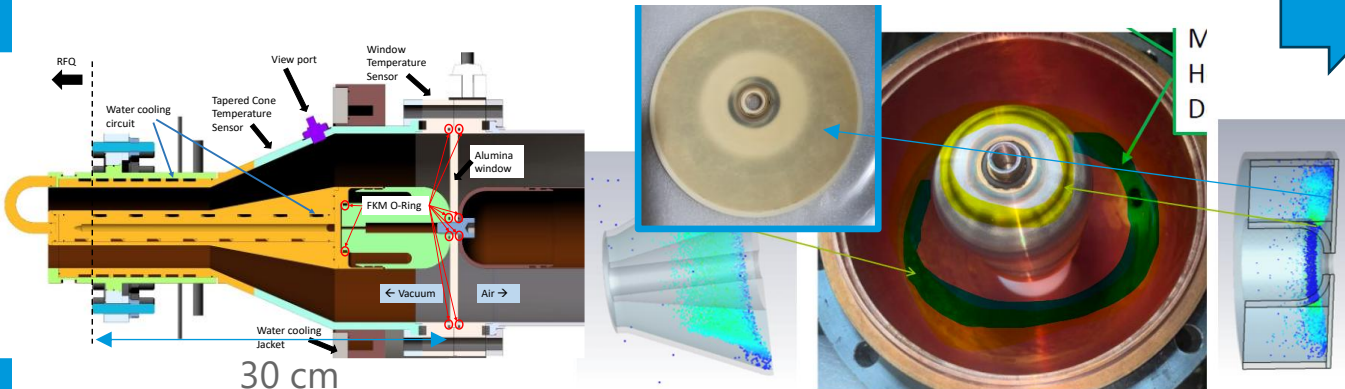

# Partial summary

## Developed projects

INFN has consolidated a **reusable workflow** for RFQ and DTL development.

The workflow is based on **early integration** of beam dynamics, RF, mechanics, metrology, and commissioning.

The most important **lessons** concern tolerance control, RF tuning range, modular assembly, RF-window reliability, and commissioning with as-built models.

Cavity **Tuning** has not been treated in this presentation. A recent complete review has been published at HB2025.

Main challenges of the presented structures:

- **Common characteristic:** < 0.1 mm global tolerance around beam axis
- **ANTHEM RFQ** → tuning of stabilized structure
- **IFMIF RFQ** → handling beam current intensity in CW
- **SPES RFQ** → low emittance and structure stiffness
- **ESS DTL** → chain of tolerances, Post Coupler tuning

### Vane Erosion yield calculation:

- erosion mainly caused by sputtering of the deuteron ions onto the Cu surface of the electrodes.
- yield larger for lower energy and tangential collisions

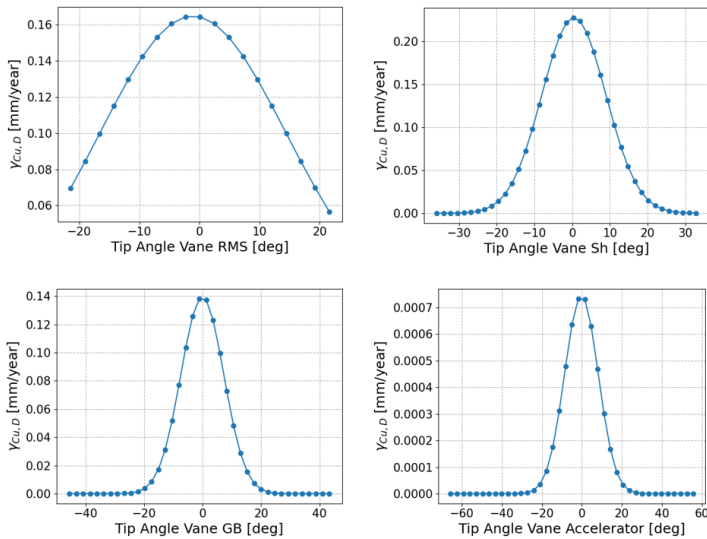

**Decrease the weight** of the modules → cross section mixed tuning on rho/R0 and Wbase

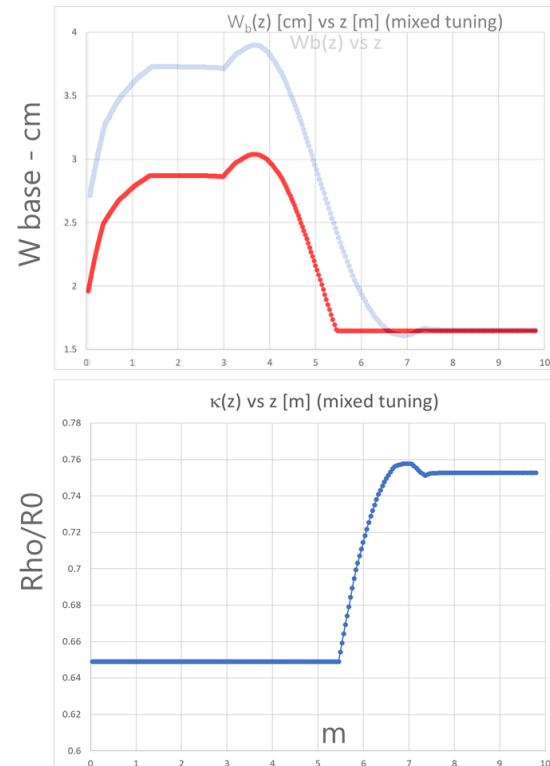

Fully automatic procedure for cell-by cell RFQ generation, no dependency on the LANL codes.

**Design of the cells** can be done for different voltage, R0, m and focusing factor B profiles, based on phase advances and design rules used in IFMIF/EVEDA.

New multipoles Tables with larger ranges of modulation and L/R0 introduced.

The **optimization process** use an evolutionary and population-based optimization algorithms.

Beam Dynamics checks with Toutatis.

Surrogate models is applied for input parameters suggestion and further optimization.

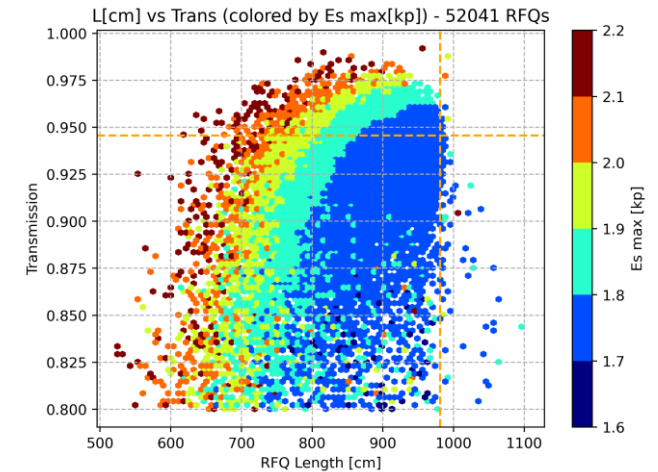

Obtained DONES RFQs, from VeRDe2 optimization: each dot is a fully multiparticles simulation done with TOUTATIS. The orange lines are the Nominal performances of IFMIF RFQ.

L. Bellan et al., WPENS report, 2021

E. Trachanas et al., Investigation of sputtering and erosion phenomena in radio-frequency quadrupoles, PRAB 2025

# Possible applications of RFQ + Alvarez DTL

## Real estate gradient vs. flexibility

The use of long Alvarez-DTL tanks in the range of velocities  $\beta=[0.05,0.4]$  has important recognized advantages in terms of **very high beam quality**, thanks to its regular lattice with embedded quadrupoles, which implies a reduction of space between tank.

This allows **high Real Estate Gradient** but comes at the cost of energy **flexibility**.

Independent powering and phasing of individual cavities does allow energy flexibility but comes at the cost of a lower effective acceleration per unit length: additional hardware (quadrupoles, diagnostics and inter-accelerating cavity transitions) increase the non-accelerating length of the machine.

### Louis Alvarez, curiosities:

Nobel prize for Physics 1968

Flying in the B-29 Superfortress *The Great Artiste* in formation with the *Enola Gay*, Alvarez wanted measured the effects of the Little Boy bomb which was dropped on Hiroshima.

He has been the first to make the hypothesis the asteroid impact caused the dinosaurs extinction.

[R. Laxdal et al., Beam dynamics comparison of different structures towards a compact accelerator based neutron source, HB 2025](#)

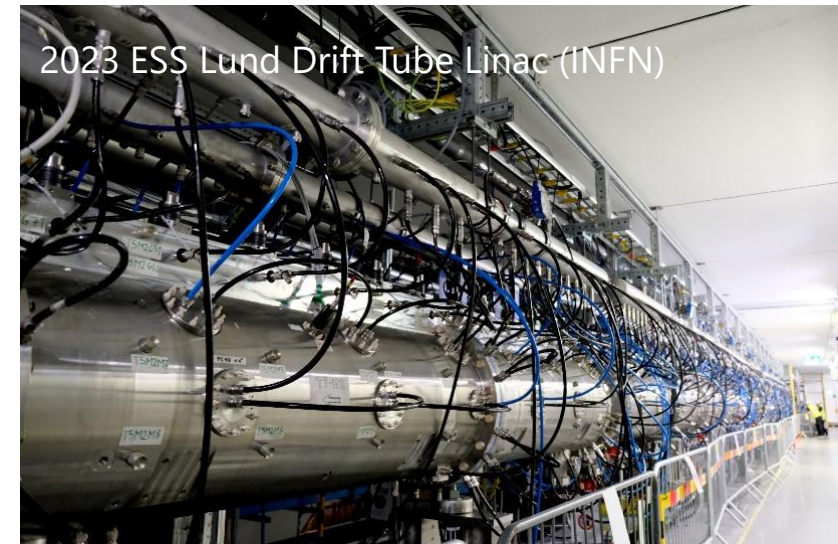
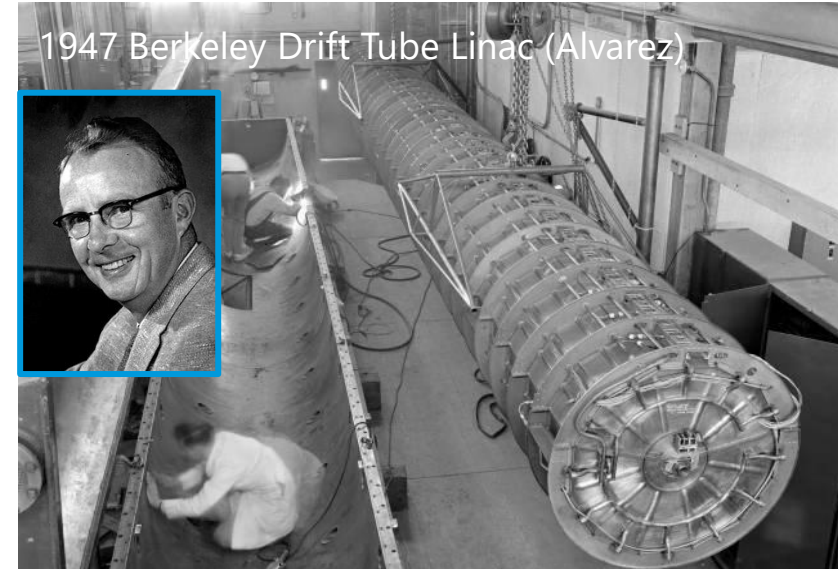

## A way to achieve energy flexibility with Alvarez-DTL

**High duty cycle linac** (ECR Ion Source, RFQ, DTL) to accelerate an average current of **0.5 mA alpha beam covering energies from few MeV to 40 MeV** to exploit different reaction routes for **radioisotope production**.

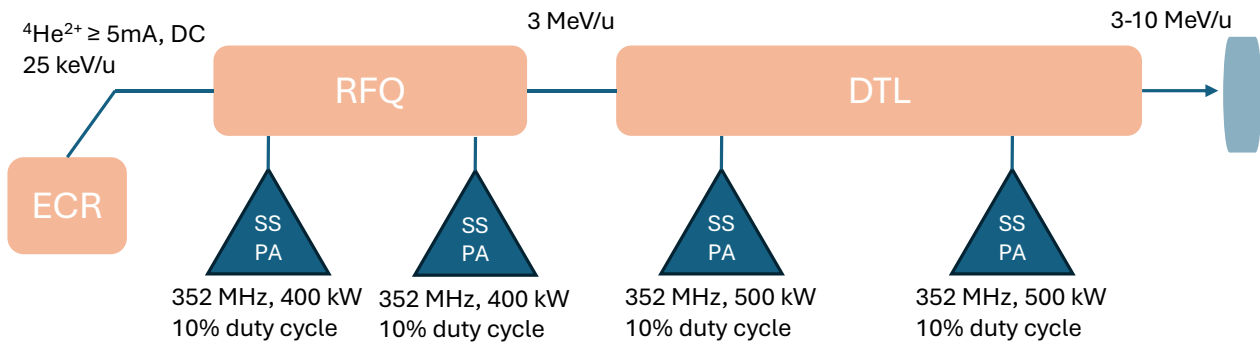

2 gears transmission:  
no axial stress.

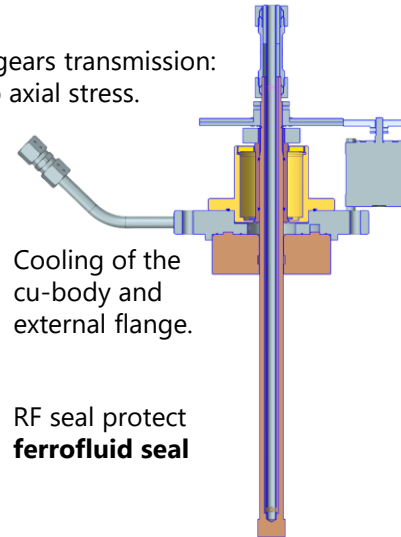

Radionuclide	Half-life	Emitted radiation (intensity)	Nuclear reaction	Energy range [MeV]
30P	2.5 min	β+ (100%)	27Al(α,n)	24 → 10
34mCl	32.2 min	β+ (55.4%)	32S(α,d)	50 → 20
38K	7.6 min	β+ (100%)	35Cl(α,n)	22 → 7
47Sc	3.3491 d	β- (100%)	44Ca(α,p)	25 → 10
61Cu	3.4 h	β+ (62%)	59Co(α,2n)	33 → 23
97Ru	2.8376 d	β+ (100%)	natMo(α,x)	30 → 10
99Mo	65.936 h	β- (100%)	96Zr(α,n)	25 → 10
103Pd	17.000 d	EC (100%)	101Ru(α,2n)	35 → 15
117mSn	13.94 d	IT (100%)	113Cd(α,3n)	60 → 30
193mPt	4.33 d	IT (100%)	192Os(α,3n)	40 → 30
195mPt	4.010 d	IT (100%)	192Os(α,n)	28 → 15
211At	7.3 h	EC (58%) , α (42%)	209Bi(α,2n)	28 → 10

Parameter	Value	Notes
Ion source	ECRIS	He <sup>2+</sup> , 50 kV
Accelerator type	RFQ+DTL	<b>352.21 MHz</b>
Beam Current	5 mA	peak
Duty cycle	10 %	
RFQ W <sub>out</sub>	3 MeV/u	
DTL W <sub>out</sub>	10.125 MeV/u	
P <sub>diss</sub> RFQ	750 kW	Peak, 25% margin
P <sub>diss</sub> DTL	800 kW	Peak, 25% margin
Total length	15 m	ISRC extraction to end of DTL

### Study of energy variation

**Rotation of the DTL Post Couplers**, to impose a step on the accelerating field. This **step will terminate the synchronous acceleration** process and will vary the beam output energy, while the PMQ channel keep transversally the beam

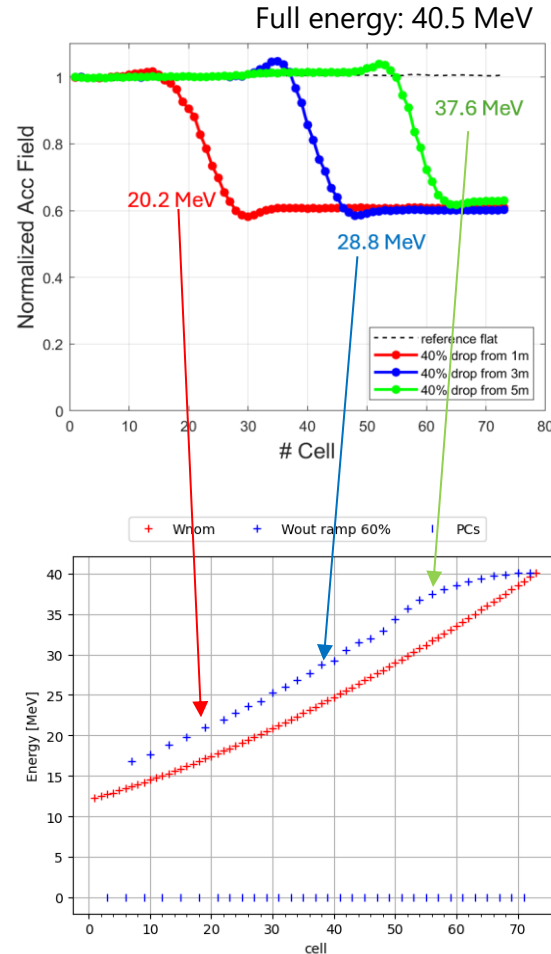
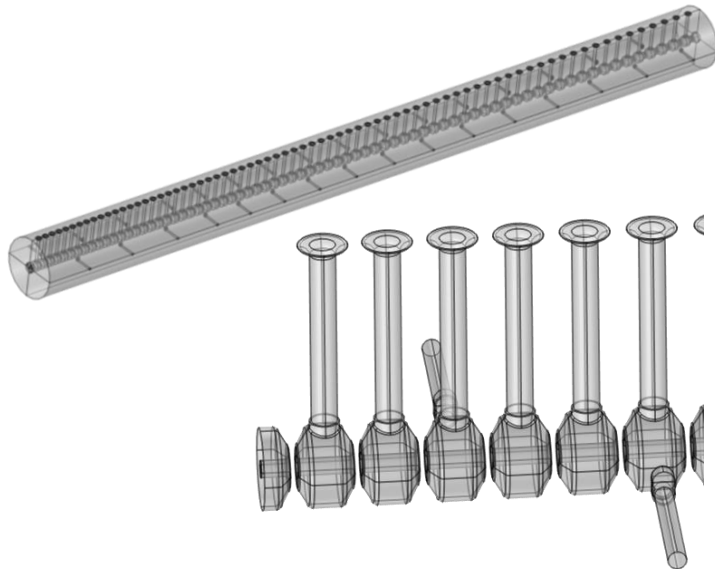

### RF power system operation

Using 2 independent RF amplifiers allows the optimization of the RF power transfer to the DTL by independently setting the power of each of them, minimizing  $P_{rev}$  for all output energy configurations.

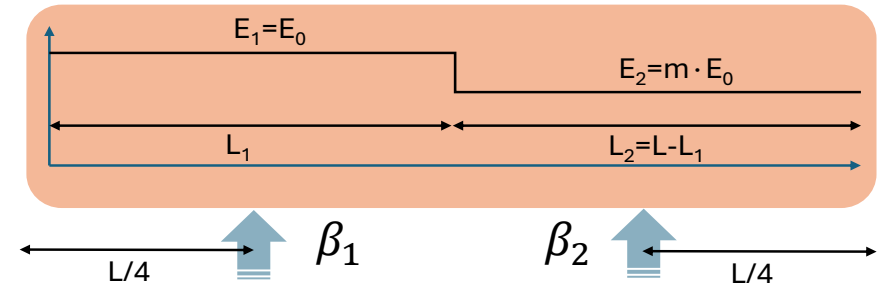

$$f(x) = \frac{P_{rev}}{P_1} = \frac{\Gamma_1^2(x) \cdot P_1 + \Gamma_2^2(x) \cdot P_2}{P_1} = \Gamma_1^2(x) + \Gamma_2^2(x) \cdot x^2$$

$$\text{Minimized for } x^2 = P_2/P_1 = \left( \frac{4\sqrt{\beta_1\beta_2}}{(\beta_1 + \beta_2)^2 + 2\beta_1 - 2\beta_2 + 1} \right)^2$$

Parameter	Case 1	Case 2	Case 3
$m$	0.6	0.6	0.6
$L_1/L$	1/3	1/2	2/3
$\beta_1$	0.87	0.73	0.63
$\beta_2$	0.31	0.27	0.23
$P_{diss}/P_0$	0.57	0.68	0.79
Optimum $P_2/P_1$	0.35	0.36	0.355
$p_{rev}^{min}$	1%	10 <sup>-5</sup> %	1%
$P_{rev}$ if $P_2 = P_1$	13%	12%	13% <b>20</b>

# ICONE compact neutron source

## The Alvarez-DTL alternative to IH-DTL

Ali Dia, THP4016, Ipac26

[R. Laxdal et al., Beam dynamics comparison of different structures towards a compact accelerator based neutron source, HB 2025](#)

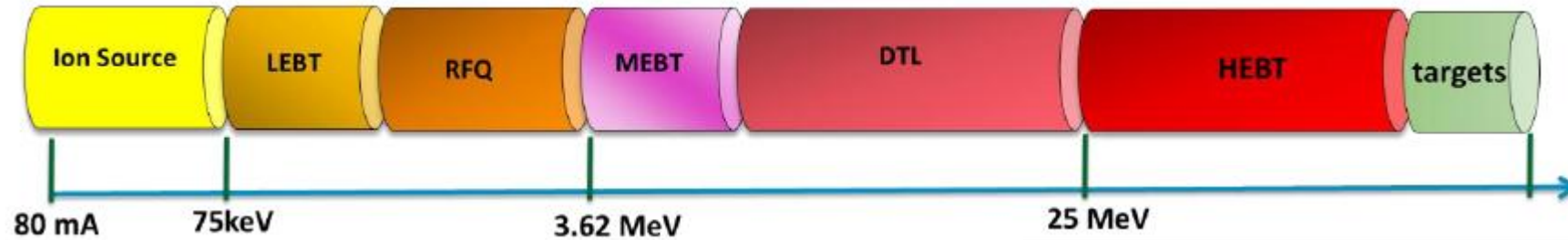

Parameter	Requirement	Notes
Input Energy	3.62 MeV	
Output Energy	>25 MeV	
Losses	< 1 W/m	99% of error cases
Nominal beam current mA	80 mA	
Beam Duty Cycle	6 %	
RF duty Cycle	9 %	
Longitudinal Emittance Growth	<10 %	Nominal
Transverse Emittance Growth	<80%	Nominal
Total Length	<20 m	
Total RF dissipation	1.5 MW	No beam

Parameter	
Cells	66
E0 [MV/m]	3.00
E <sub>max</sub> /E <sub>k</sub>	1.62
φ <sub>s</sub> [deg]	-35, -20
<b>L<sub>Tank</sub> [m]</b>	<b>8.76</b>
R <sub>Bore</sub> [mm]	10
LPMQ [mm]	50, FFDD
DT diam [mm]	90
Tank diam [mm]	521
Tun. Range [MHz]	±1
Q <sub>0/1.25</sub>	43800
P <sub>cu</sub> [kW]	1200
(SFish*1.25)	
E <sub>out</sub> [MeV]	25.4
PTOT [kW]	2945

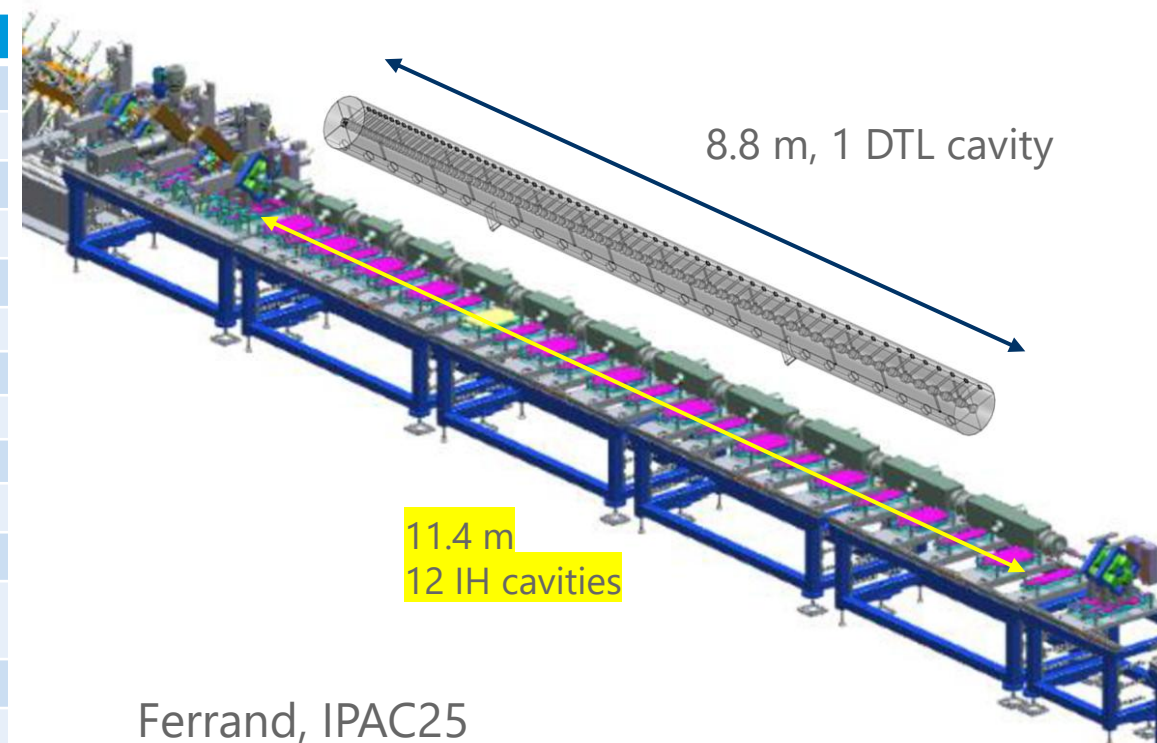

Ferrand, IPAC25

# Conclusions

The application of some key inventions as well as the general advance of the technologies (mechanics, RF, vacuum, material quality) have continuously improved the RFQ and DTL performances along the decades.

Thanks to the understanding of the high intensity beam theory, the improved models of the space charge mechanism, reliability of the modern simulation codes, the advancements in construction technology, it is now possible to obtain very high average currents from pulsed linacs.

If RFQ's are nowadays considered essential to start an ion linac, Alvarez-DTL structure is an attractive option for pulsed high current linacs up to 100 MeV, like small facilities serving industries, medical centres or compact neutron sources.

As a further feature, the use of post coupler stabilizing system to obtain flexible output energy from an Alvarez-DTL can be tested and considered.

**Thank you for the attention!**



Istituto Nazionale di Fisica Nucleare  
CONSIGLIO PRELIMINARE DEL TRIESTE 1964/1971

# Back up

# As-built simulations

Check the as-verified status of the cavity for beam performances

## IFMIF Lipac

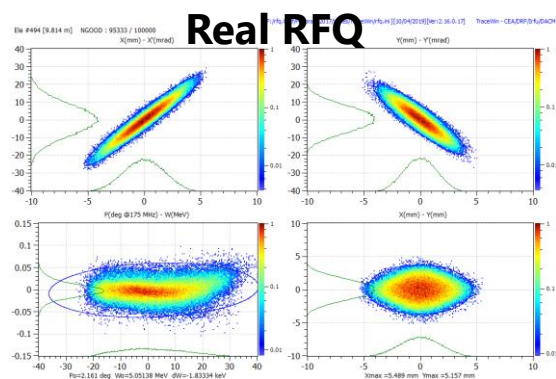
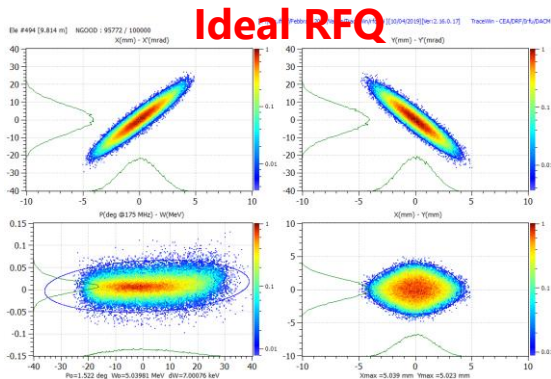
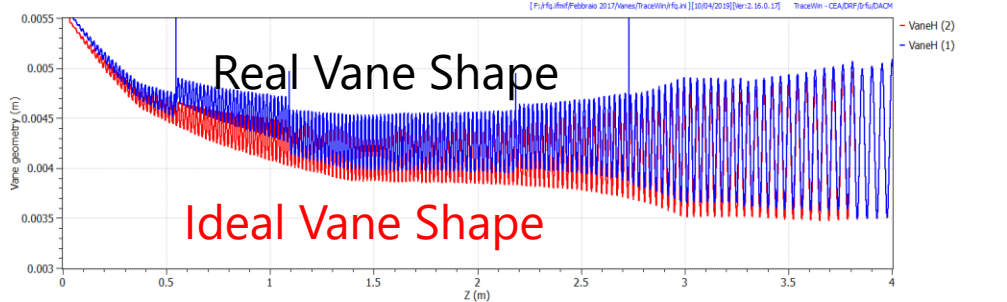
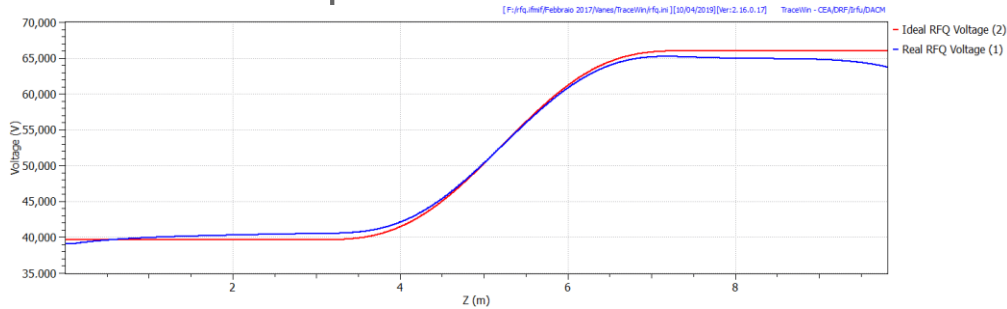

## ESS DTL

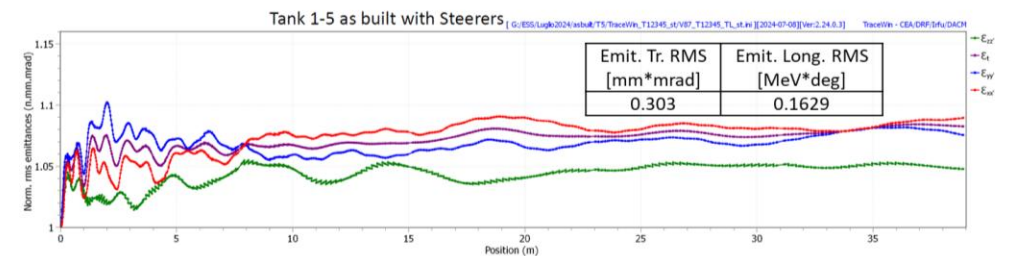
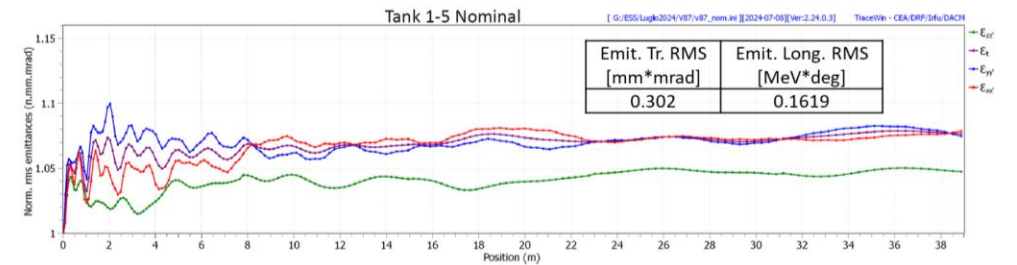
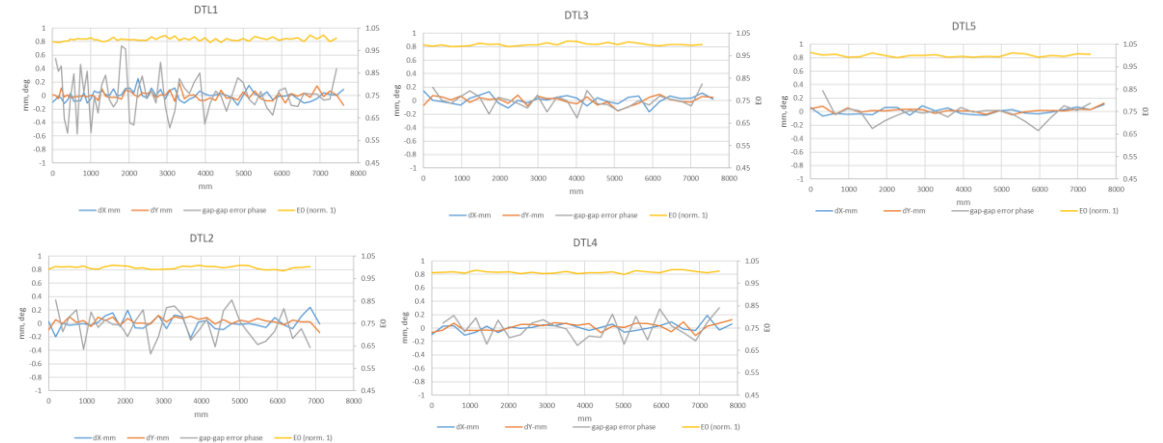

### Input emittances for He<sup>2+</sup> beams

ECRIS	$\epsilon_{H,RMS}^{norm}$	$\epsilon_{V,RMS}^{norm}$	$I_{He^{2+}}$	$V_{extr.}$
AISHA-LNS	0.42 mm.mrad	0.42 mm.mrad	5.4 mA	20 kV
AISHA-CNAO	0.55 mm.mrad	0.40 mm.mrad	1.9 mA	16 kV
HECRAL-IMP	0.51 mm.mrad	0.30 mm.mrad	8.8 mA	30kV

### Design challenges:

- High input emittance (0.4 mm.mrad)
  - Mixed space-charge/emittance dominated regime ( $K \cdot a^2 / \epsilon_{geom}^2 \approx 1.1$ )
  - Variable  $V(z)$  and  $R0(z)$
  - $L_{RFQ} < 6 m_i$ , to avoid the use of stabilizing coupling cells
  - disadvantageous  $\lambda^2 / mc^2$
- $$B = \frac{\lambda^2}{c^2} \frac{e}{m} \frac{\chi V}{a^2}$$

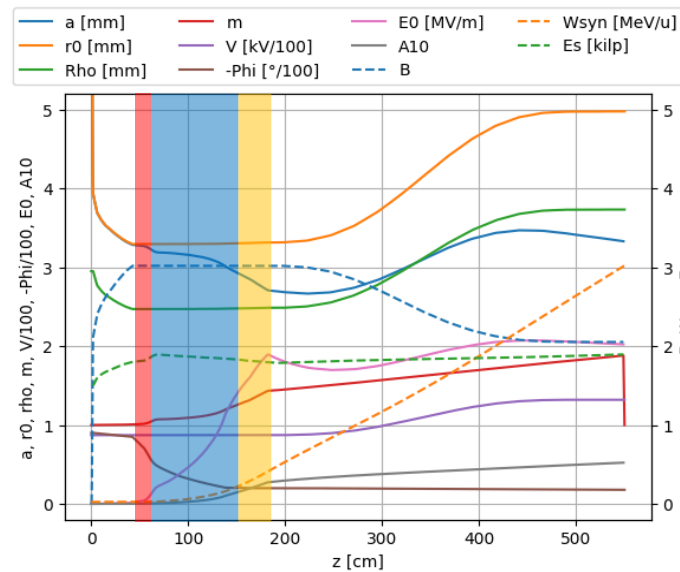
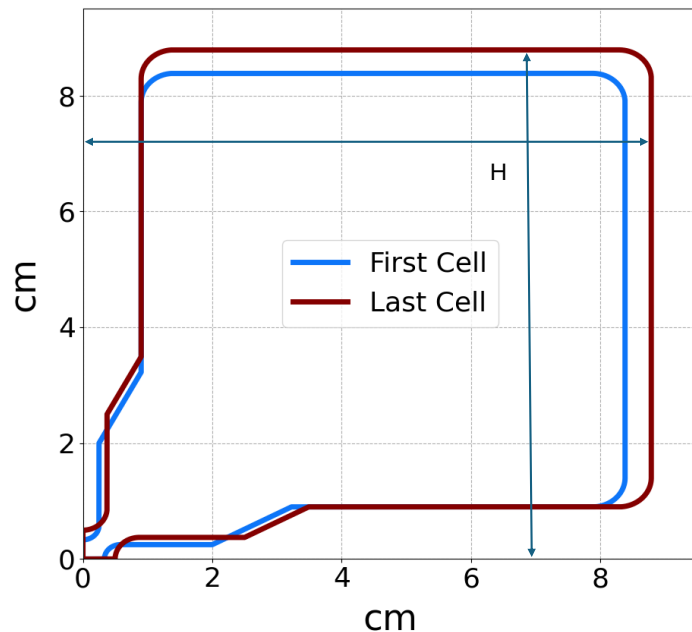

Pre-buncher (red), adiabatic buncher (blue), booster (orange).

RFQ parameter	Value	unit
Length L	5.50	m
Voltage Min/Max	87.14/132	kV
Max modulation	1.88	
R0 min/Max	3.7 / 5.0	mm
Ratio p/R0 (constant)	0.75	
Final Synchronous phase	-17.8	deg
Shunt impedance	94-110	k $\Omega$ .m
Transmission (waterbag)	86.0	%
Out. $\epsilon_{long,RMS}^{norm}$	0.073	MeV.deg
Out. $\epsilon_{tran,RMS}^{norm}$	0.4	mm.mrad



Istituto Nazionale di Fisica Nucleare  
FRENCH INSTITUTION FOR NUCLEAR PHYSICS

# (Not Only) Assembly, alignment, transport

## Control system development

### IFMIF RFQ Project

— Proven —



### ESS DTL Project

— Delivered —

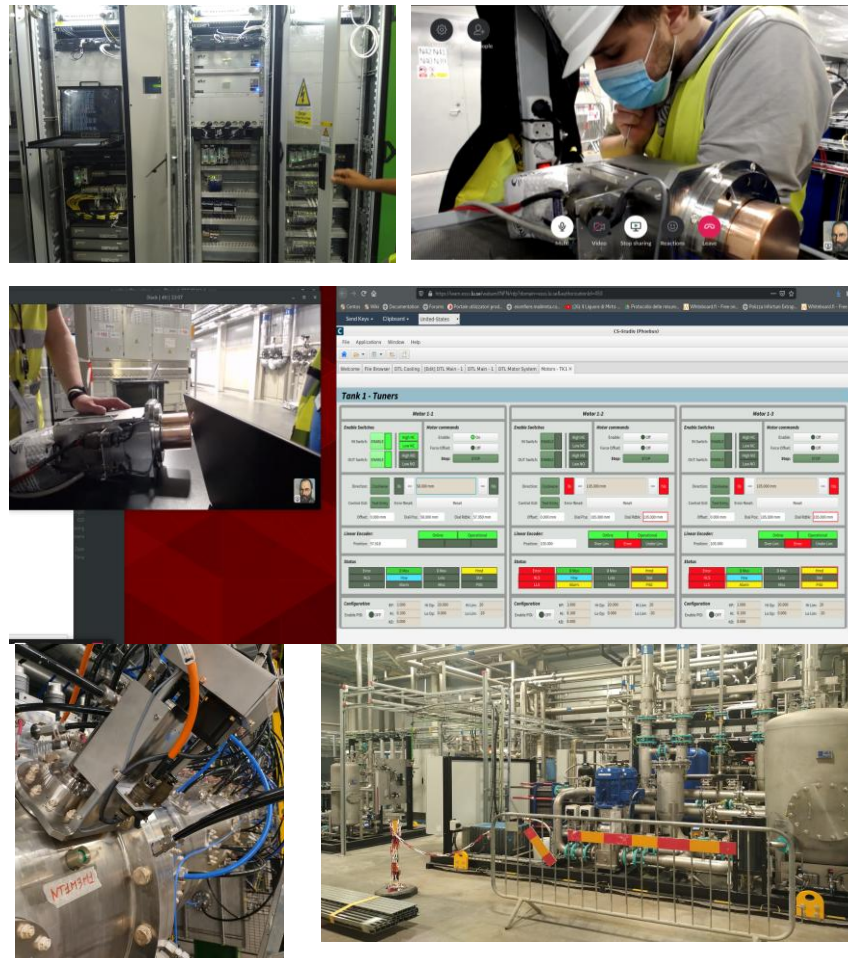

### ANTHEM Project

— Next —

