



ML-driven Automated Tuning of SACLA XFEL: Progress and Future

17th International Particle Accelerator Conference (IPAC'26) @Deauville, 2026/05/19

Eito Iwai, on behalf of SACLA/SPring-8 staff

JASRI/RIKEN SPring-8 Center



SACLA/SPring-8

- Synchrotron radiation facility@Hyogo prefecture in west Japan

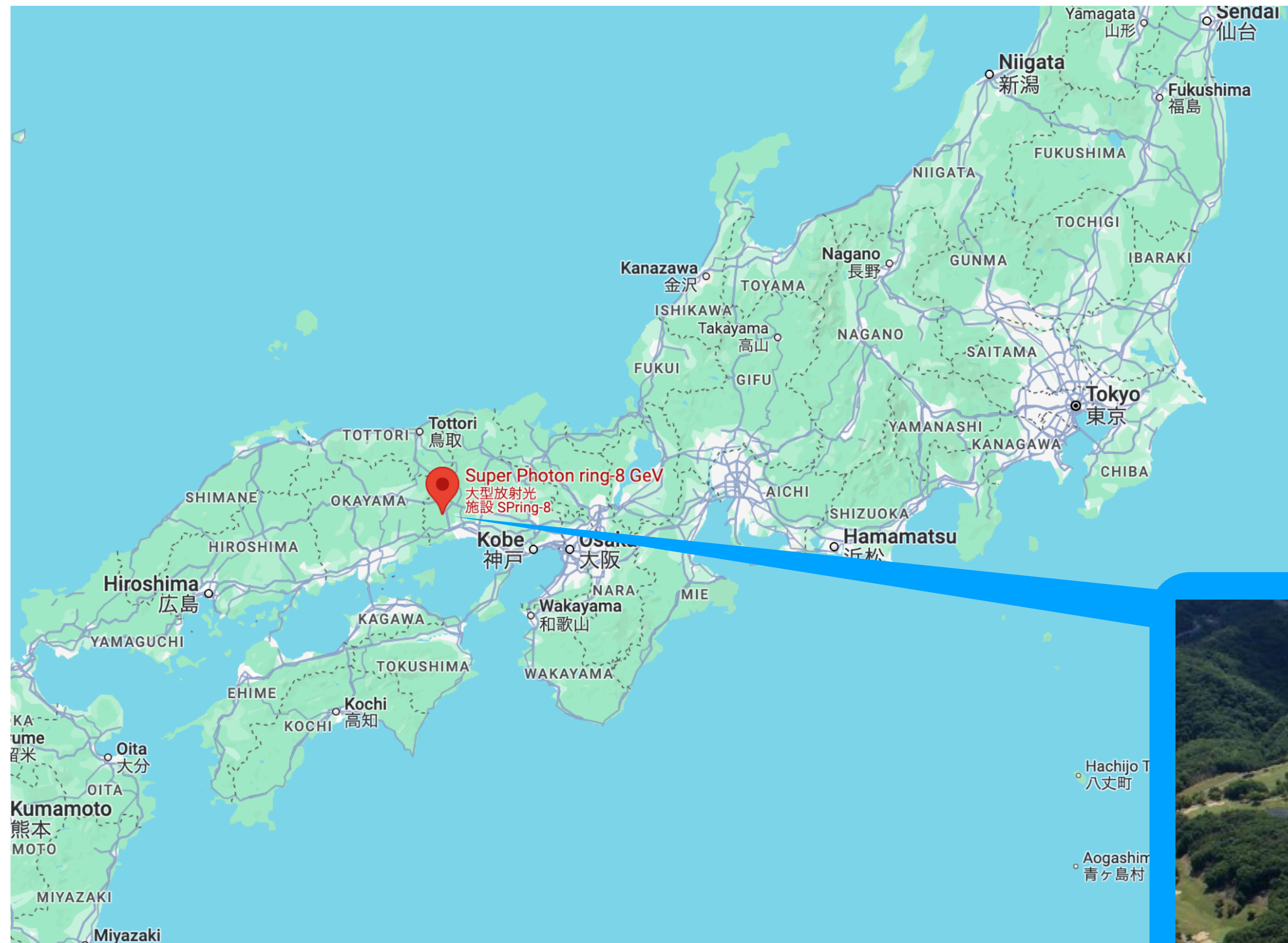

SACLA: SPring-8 Angstrom Compact free electron LAser

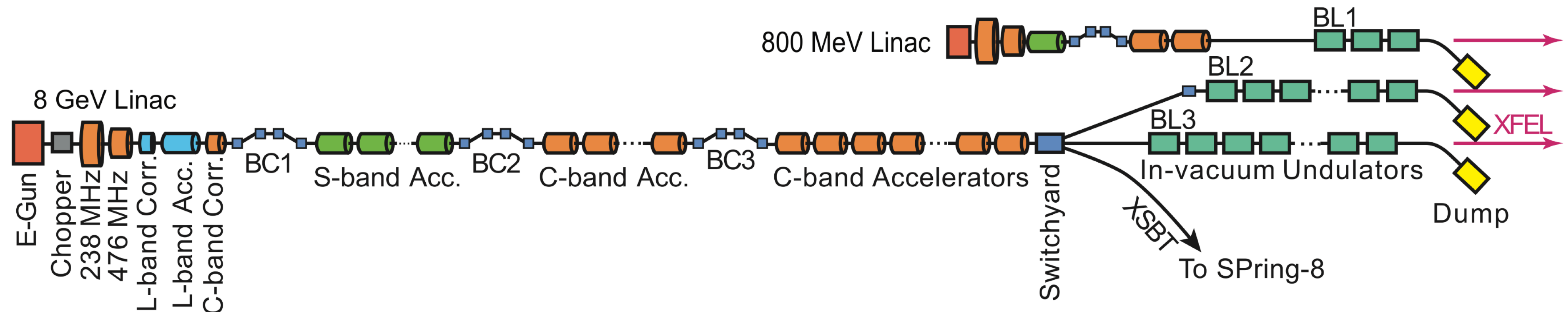

- ▶ 3 FEL beamlines
 - BL3: Hard X-ray FEL (4-15 keV)
 - BL2: Hard X-ray FEL (4-15 keV)
 - BL1: EUV FEL (20-150 eV)
- ▶ 2 normal conducting accelerators (8 GeV and 800 MeV linacs)
 - CeB6 thermionic gun
 - High gradient C-band main linac
 - Variable gap, in-vacuum undulators

Rationalization of acc. operations

- ▶ Depending on brightness in 6-D phase space
 - complex spiky structures in ~10fs of compressed pulse
 - velocity bunching w/ thermionic gun (500 keV): non-linear b/w E and β
 - density non-uniformity by shot noise (no laser heaters)
- ➔ Difficult beam tuning by watching beam response is required

- ▶ Requirements in tuning, operation
 - different wavelengths, conditions for 3 FEL BLs
 - wavelengths, conditions are changed every a couple of days
 - Two of those BLs share main linac, pulse-by-pulse switching operation
 - Also as a injector to SPring-8 SR starting from 2020/02 (→ SPring-8-II)
 - Demand for further “better” XFEL (pulse width, clean profile, pointing stability ...)
 - Further higher availability (top-up operation)
- ➔ Applying Machine-Learning technique to operations



ML applications at SACLA/SPring-8

- ▶ Anomaly detection of thyratrons
 - Bayesian inference, PCA
- ▶ Beam optimizer
 - Bayesian optimization with Gaussian Process

Anomaly detection

Anomaly detection; thyratrons

- ▶ Final goal is to detect indications of serious troubles only happen once in 10 years
- ▶ Before touching serious but rare events, we selected thyratrons as the target of anomaly detection
- ▶ Thyratrons
 - A kind of gas-filled tube used as a high-power electrical switch (50kV, 5kA) to generate pulsed RF with klystrons
 - Product life time is 15-25k hours ~ 2.5-4 yrs (operation: ~6k hours/year)
 - ~8M JPY (50k USD) or even more according to recent currency exchange rate
 - ~ 80 units are used ; 20-30 thyratrons replaced in a year
 - Serious issue on maintenance cost
 - Reasonable number of failure samples

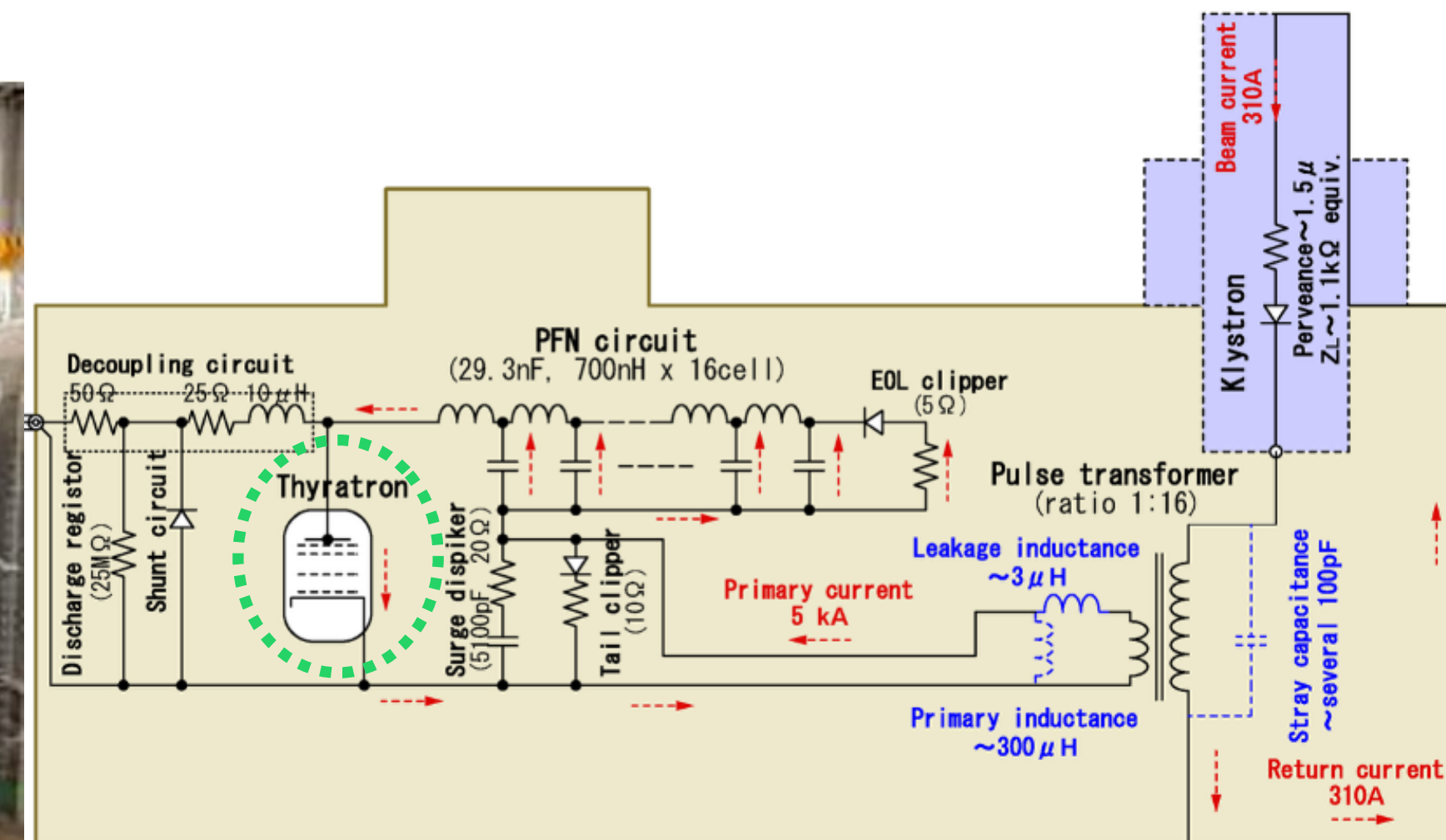
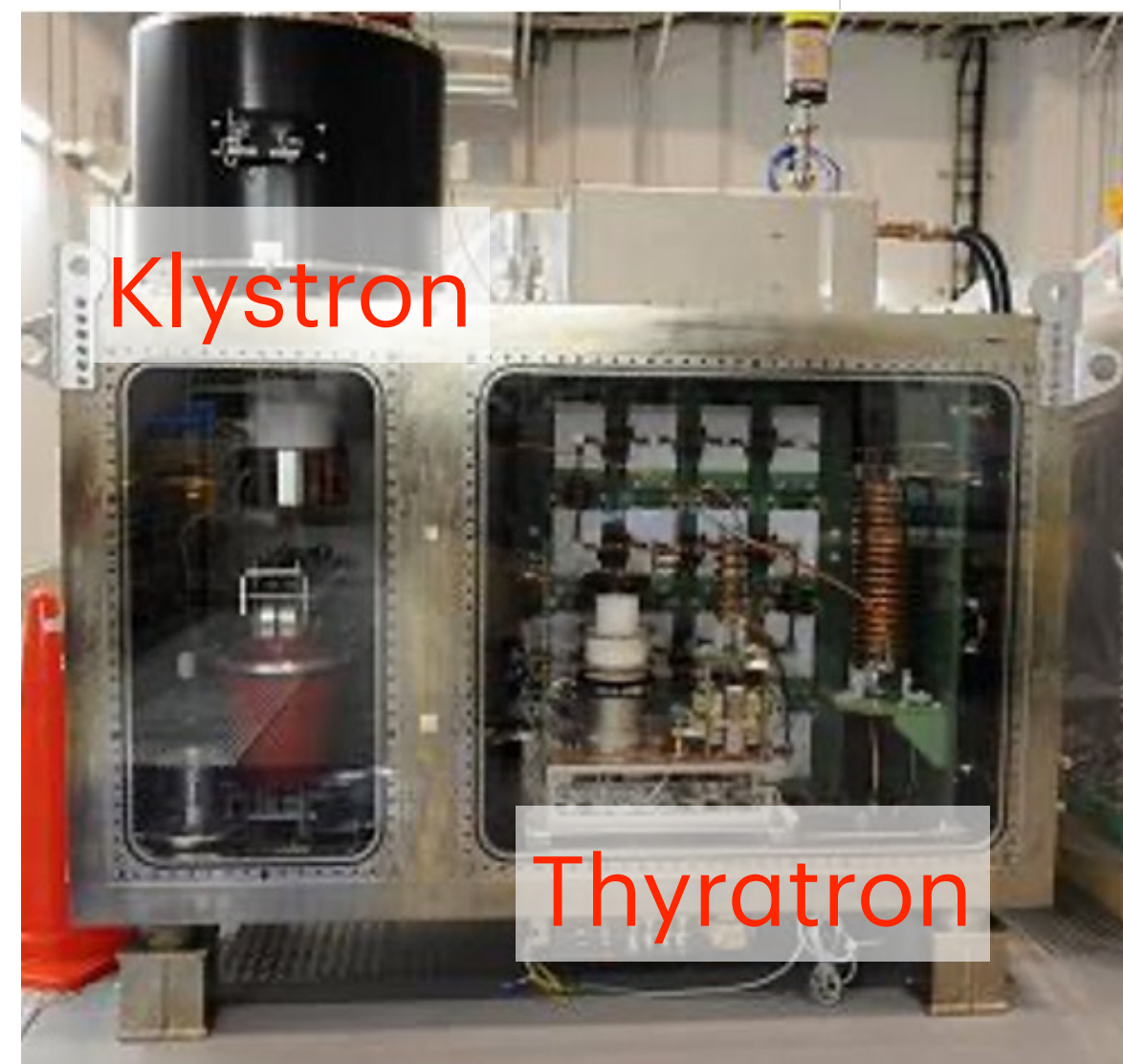

Klystron modulator in SACLA

Anomaly detection; thyratrons

- ▶ Thyratrons have two major failure modes
 - Rapidly increasing self-discharge rate
 - Other aging phenomena including surge over-voltage
- ▶ The first group can be monitored by using **Bayesian inference**
- ▶ The latter group can be identified with waveforms by using PCA based method [WiP]

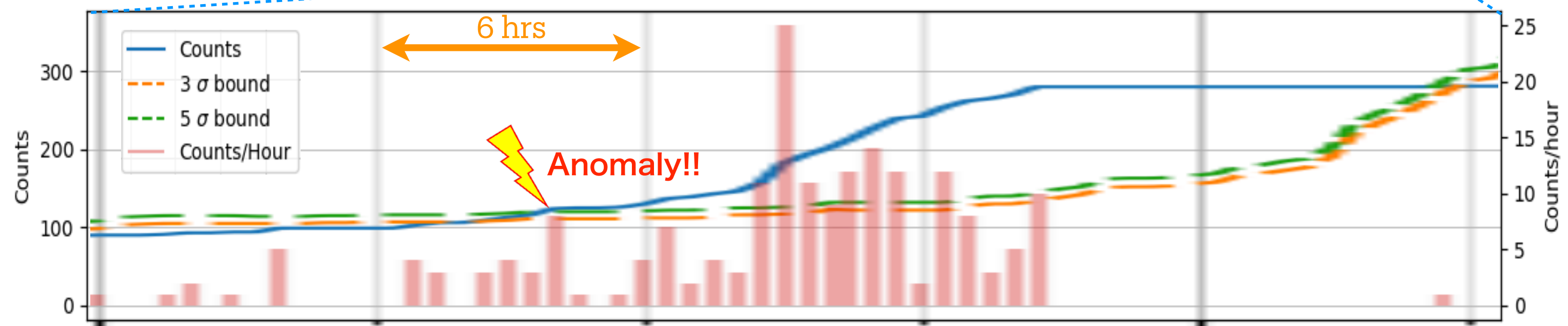
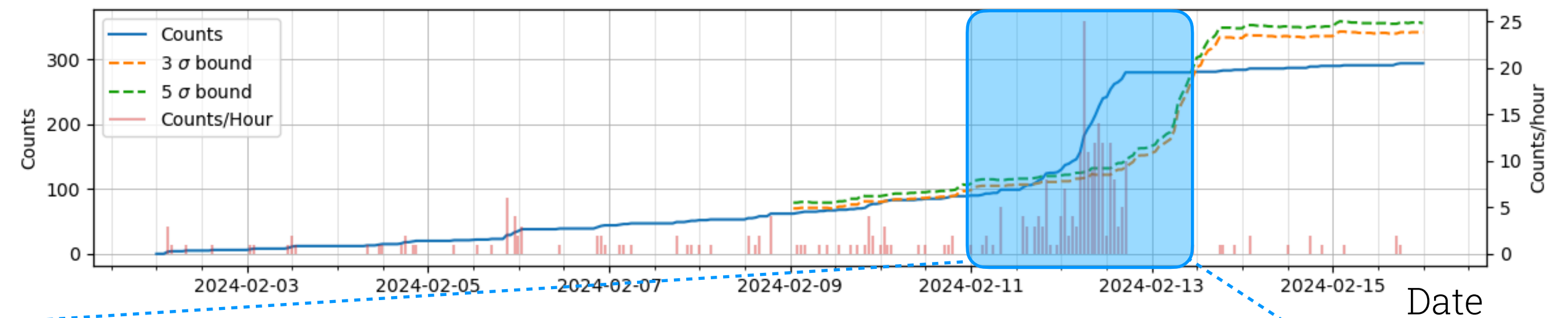
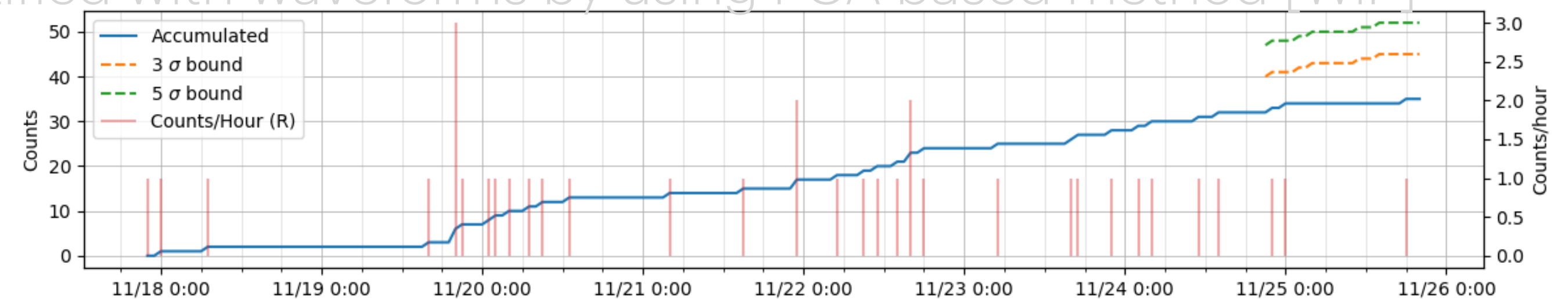

↑ Identified by operator

Anomaly detection; thyratrons

- ▶ Thyratrons have two major failure modes
 - Rapidly increasing self-discharge rate
 - Other aging phenomena including surge over-voltage
- ▶ The first group can be monitored by using Bayesian inference
- ▶ The latter group can be identified with waveforms by using PCA based method
 - Waveform evaluation based on grid waveforms taken at test-stand
 - Started continuous monitoring of approximately half of total in operation

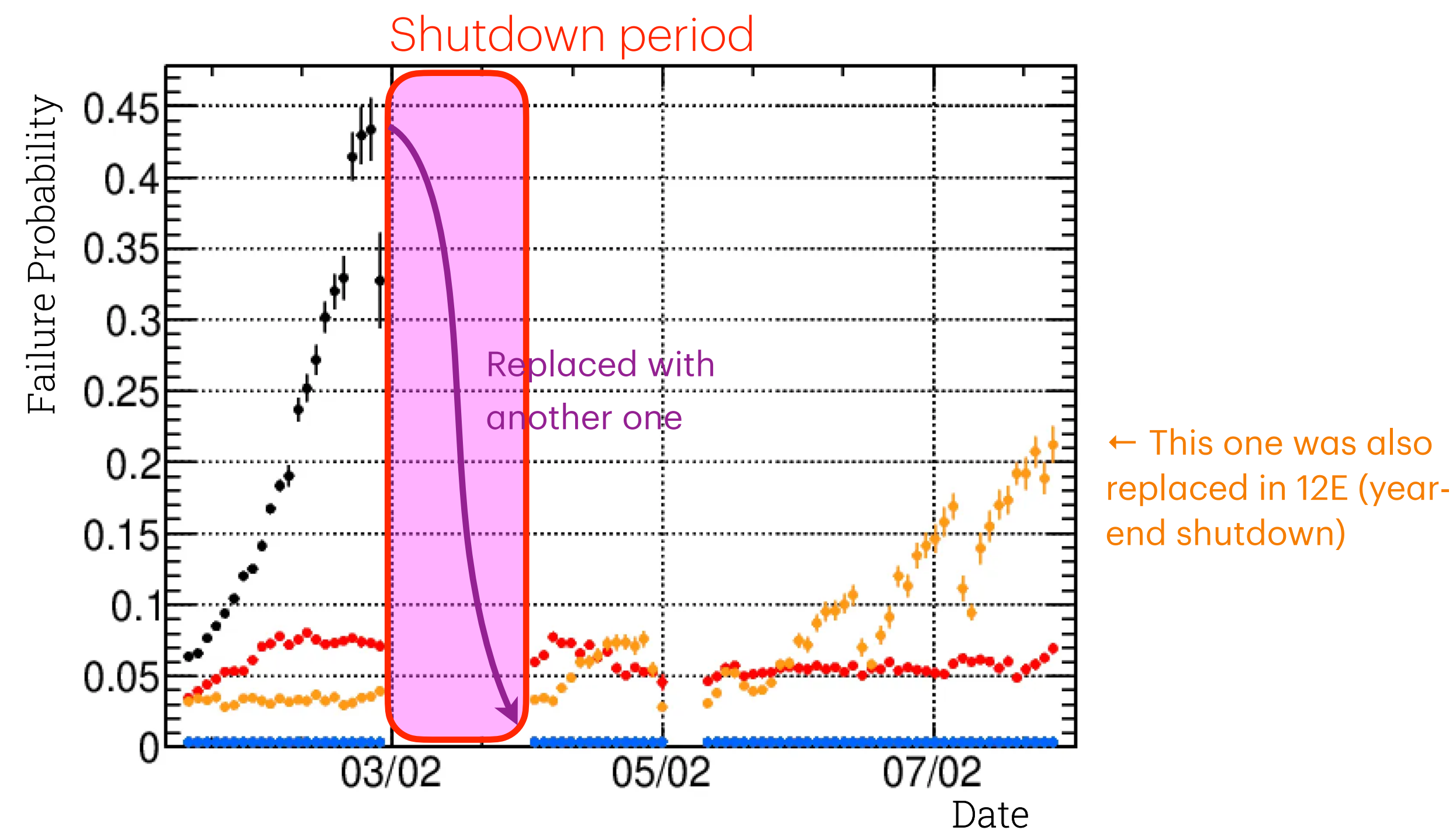
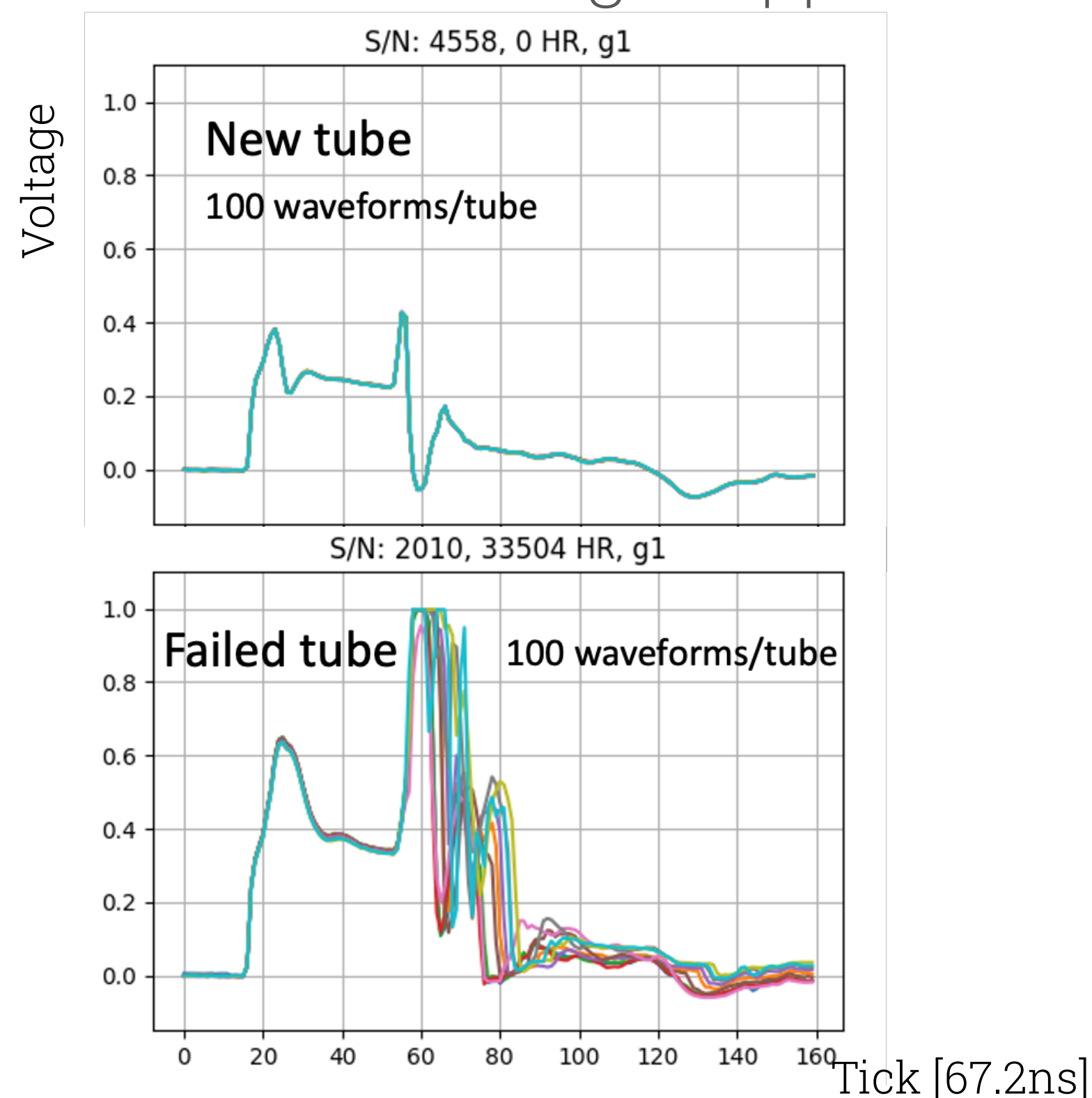

Beam optimizer

Beam optimizer

- ▶ Build our own optimizer based on Gaussian Process Regression (GPR)
 - Operation becomes more complicated even though the tuning time becomes constrained
 - Dedicated GUI was prepared and introduced in 2020, and now widely used for daily-tuning by operators
 - Fully utilize the improved tunability and flexibility for efficient tuning and better XFEL performance
- ✓ Thanks to rationalization of operation with the optimizer, we can provide more or less equal XFEL performance even after starting beam injection from SACLA to SR

Templates of control parameters for purposes and sections

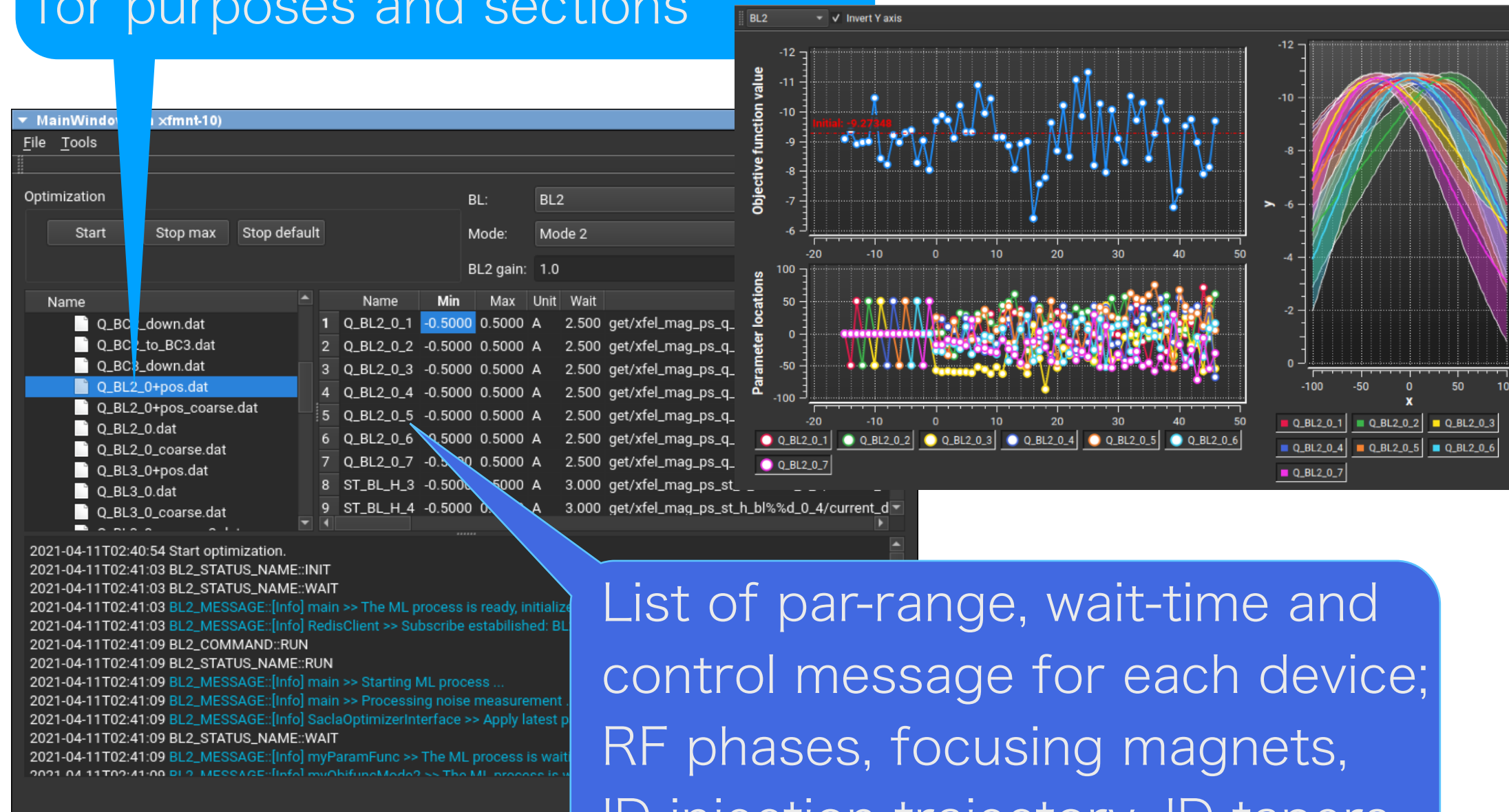

List of par-range, wait-time and control message for each device; RF phases, focusing magnets, ID injection trajectory, ID tapers



Recovery after long shutdown period

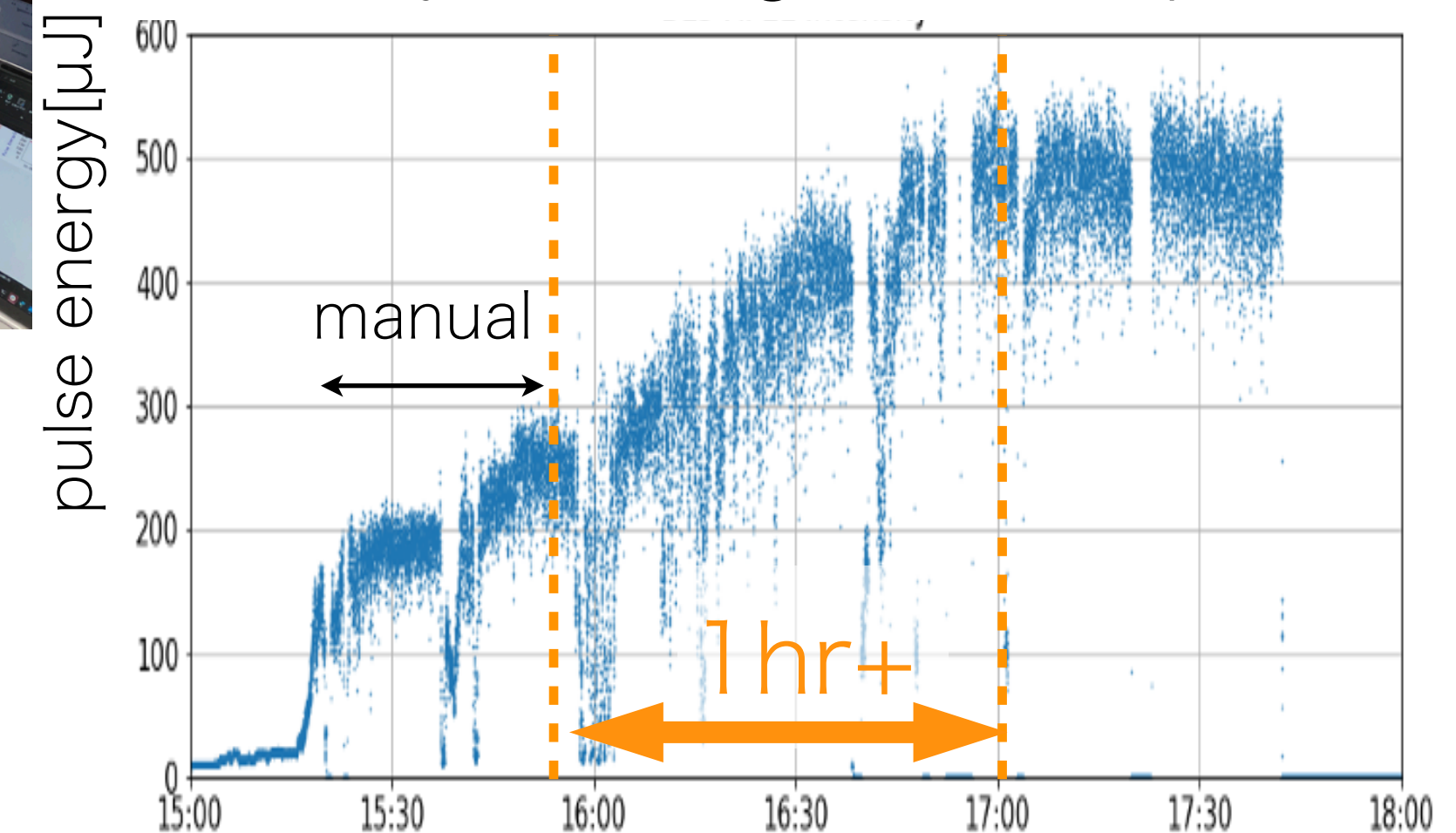

Various optimization - Spectral Brightness

- ▶ A new spectrometer with enough resolution to measure s-by-s pulse-width online installed permanently
- ▶ Optimize the spectral brightness with data obtained by the new spectrometer

- P-index:
$$\frac{\text{PulseEnergy}[\mu\text{J}]}{\sigma[\text{eV}]}$$

$$\sigma^2 = \sigma_{\text{mean}}^2 + \sigma_{\text{width}}^2$$

- σ_{mean} : fluctuation of central wavelength
- σ_{width} : spectral width for each pulse

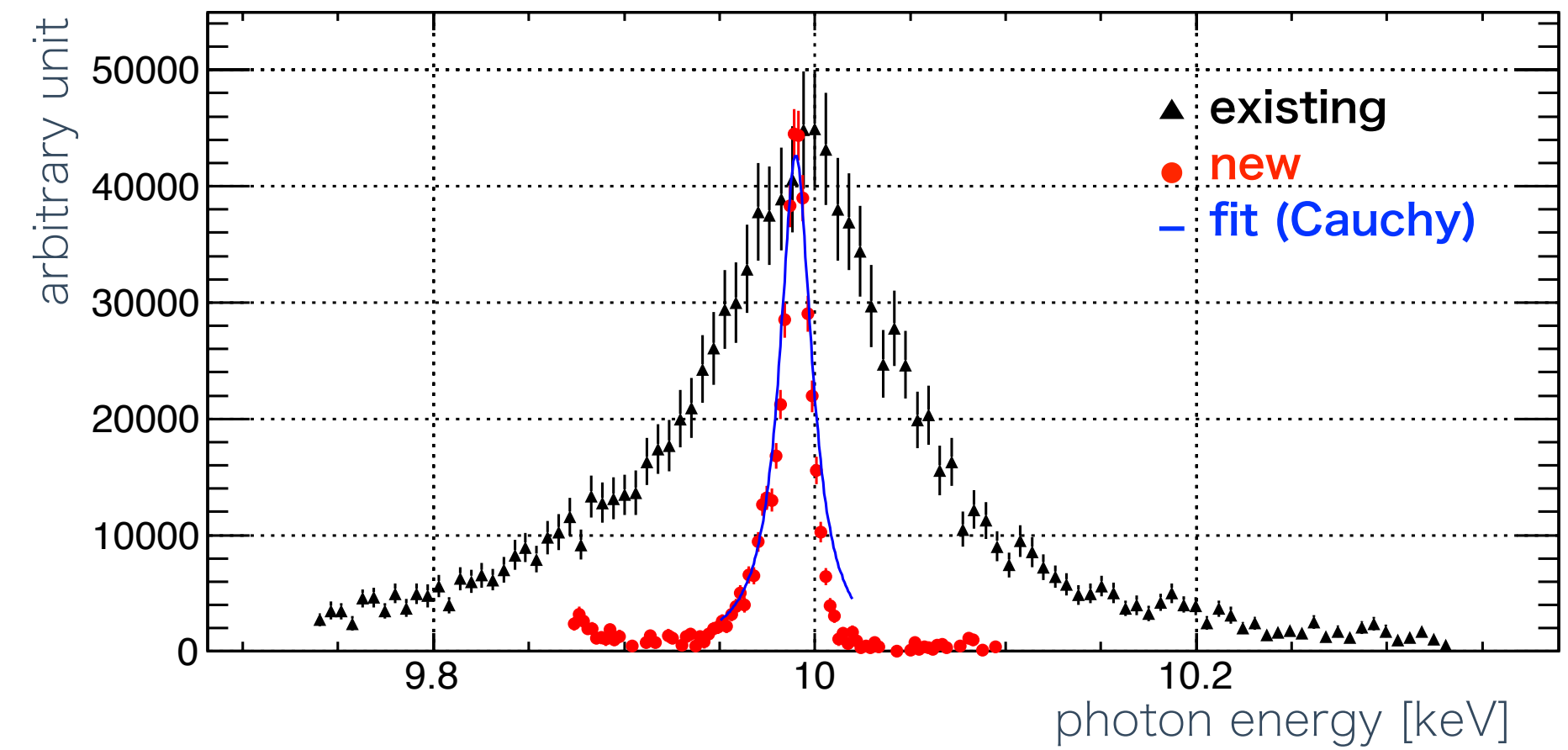

✓ Spectral brightness of central wavelength is improved by a factor of 1.7 (Pulse-energy/integrated-sum is similar at that time)

before
after

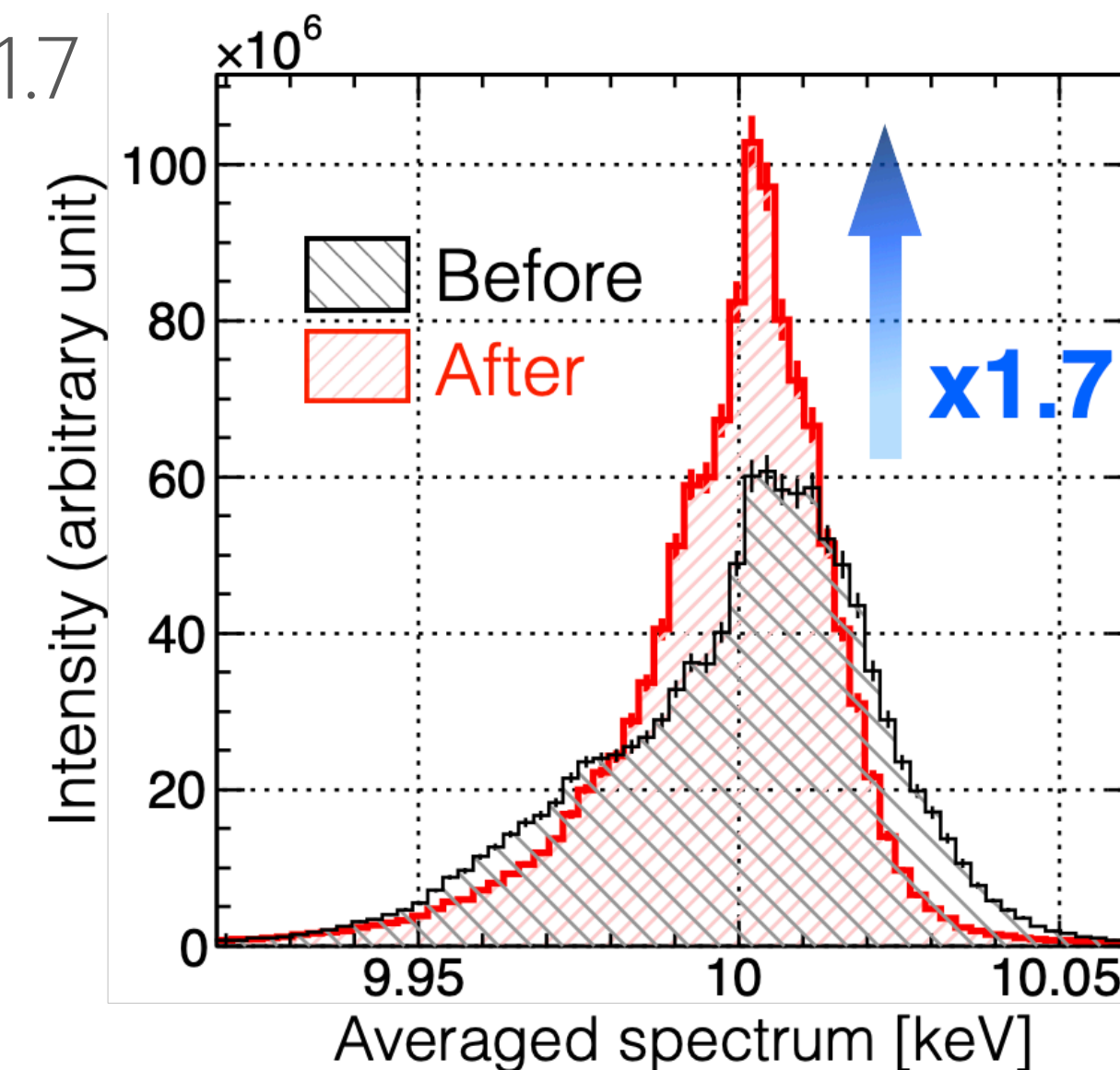
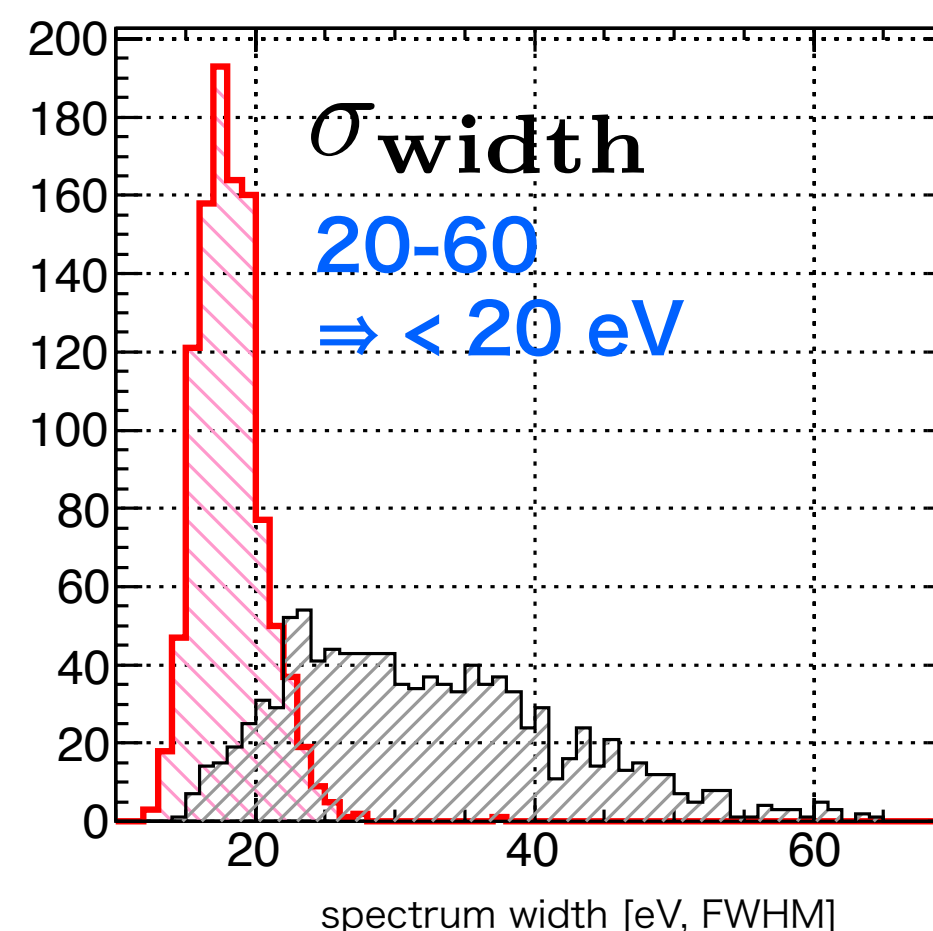
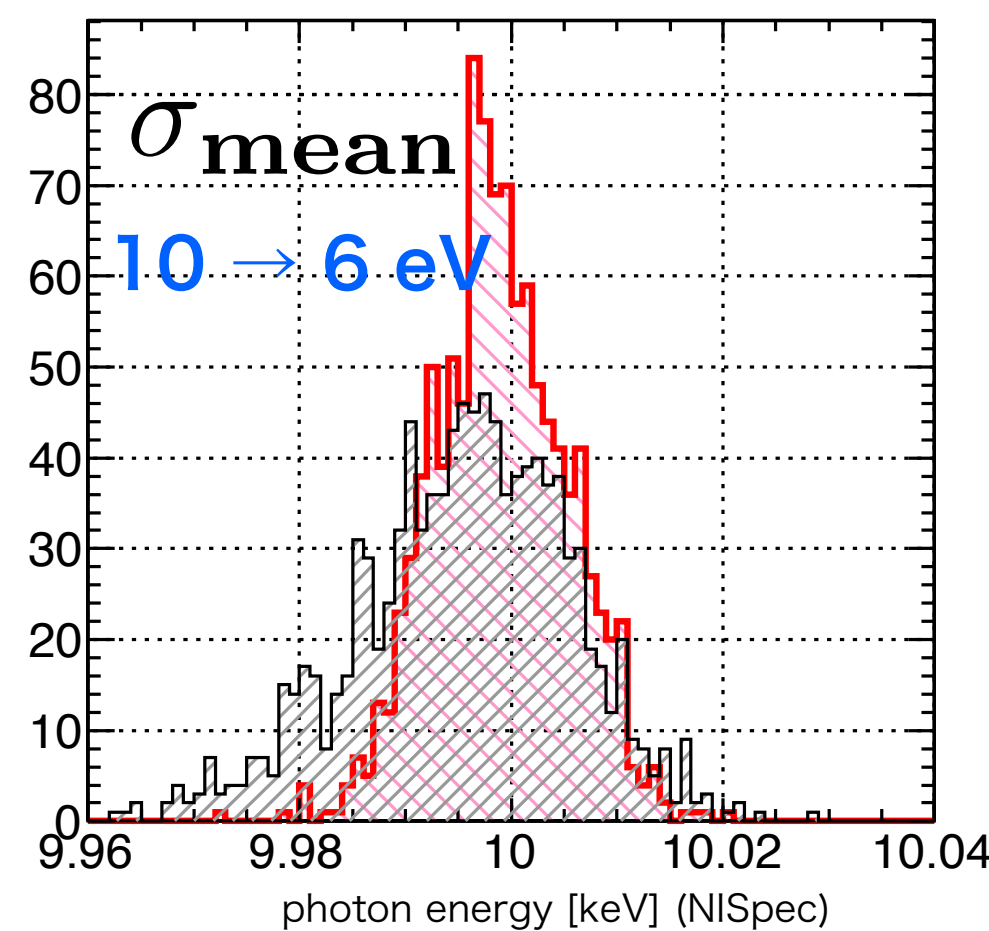

Various optimization - Spectral Shape

- ▶ Specific request from user: "Suppress peak height in side-band less than 3% of one of central wavelength"
 - A "shoulder" often remains in spectrum even after the spectral brightness optimization
 - Apply "weight" as a function of sub-peak height to suppress the shoulder and reshape the spectrum

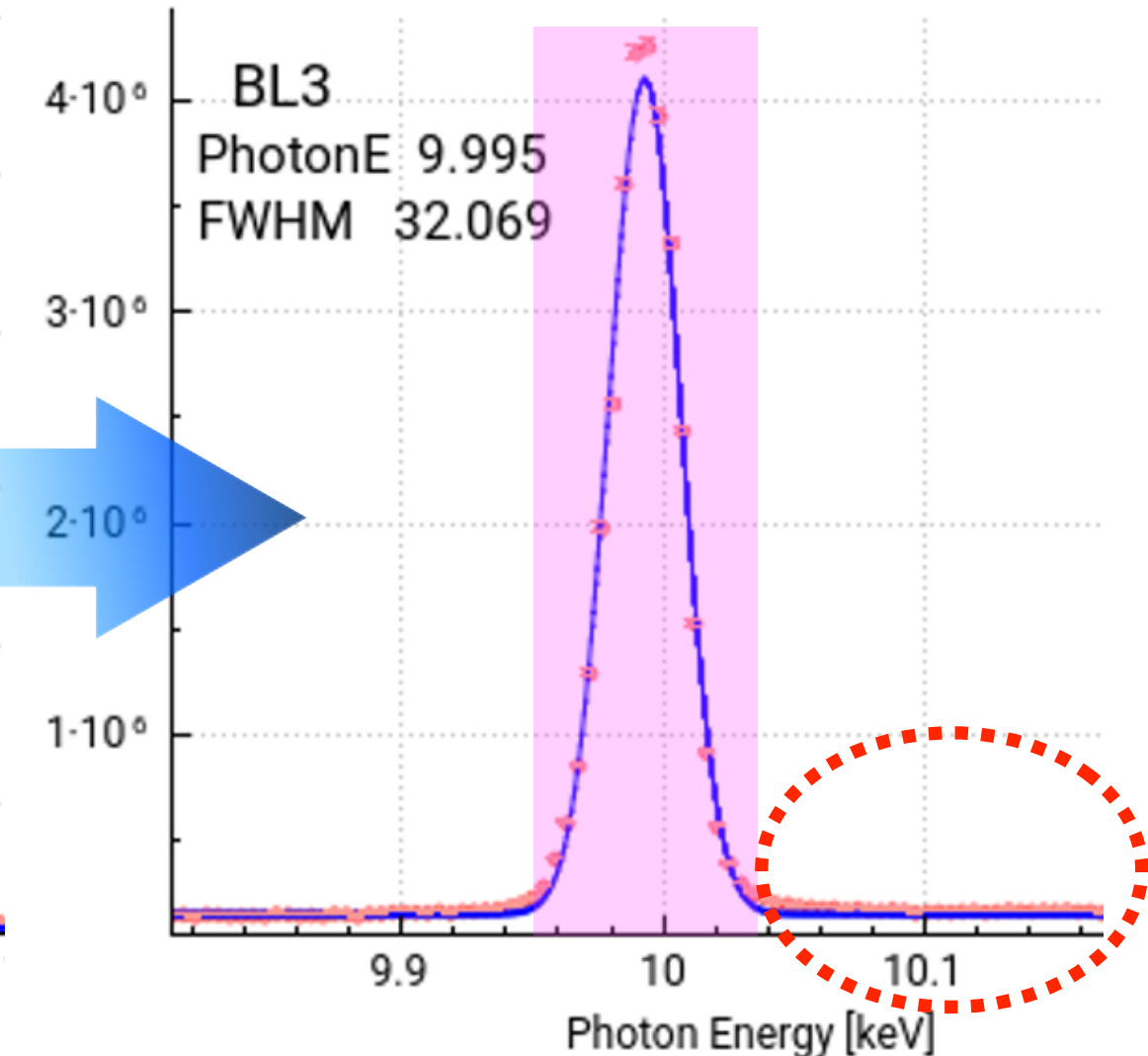
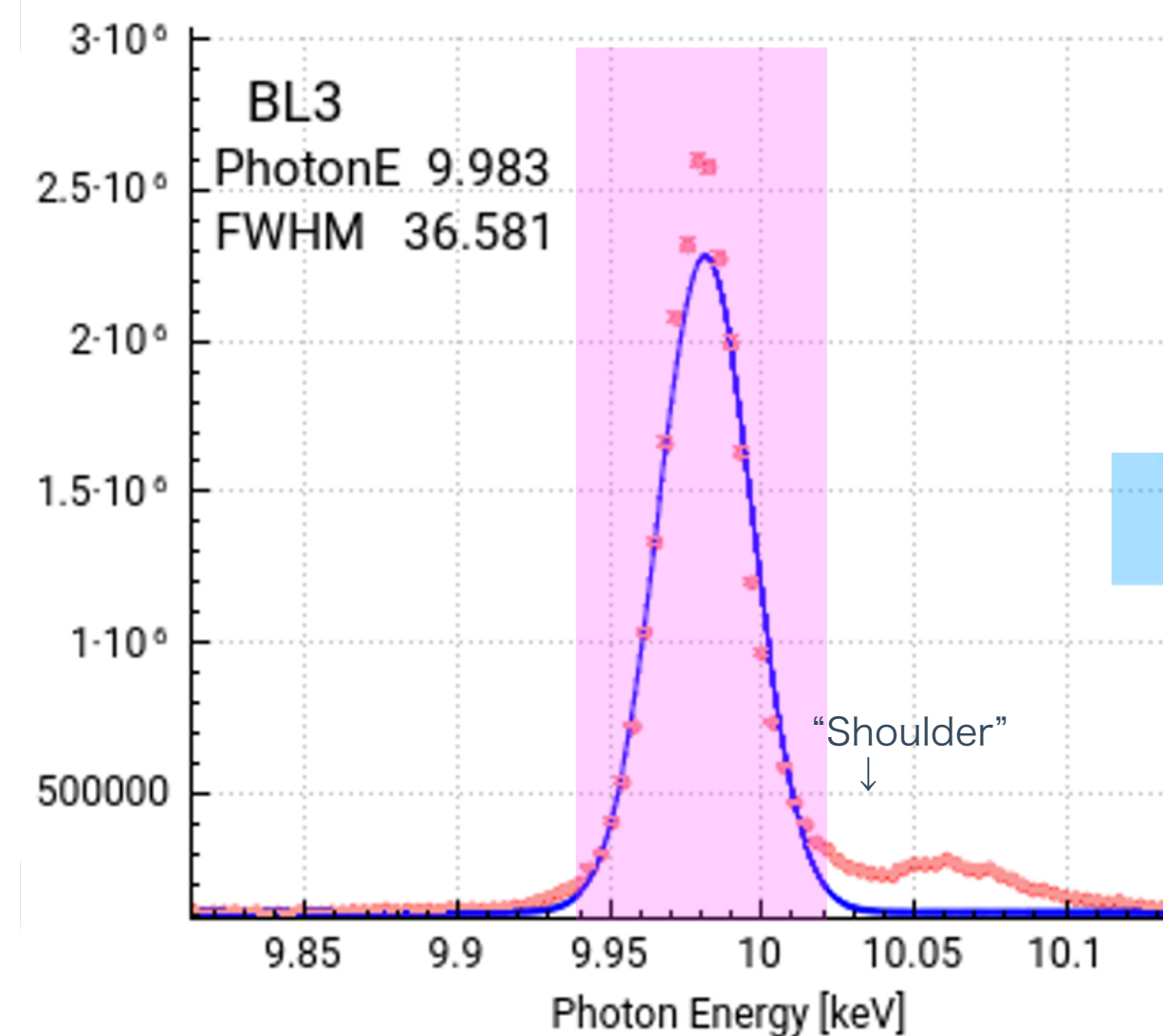
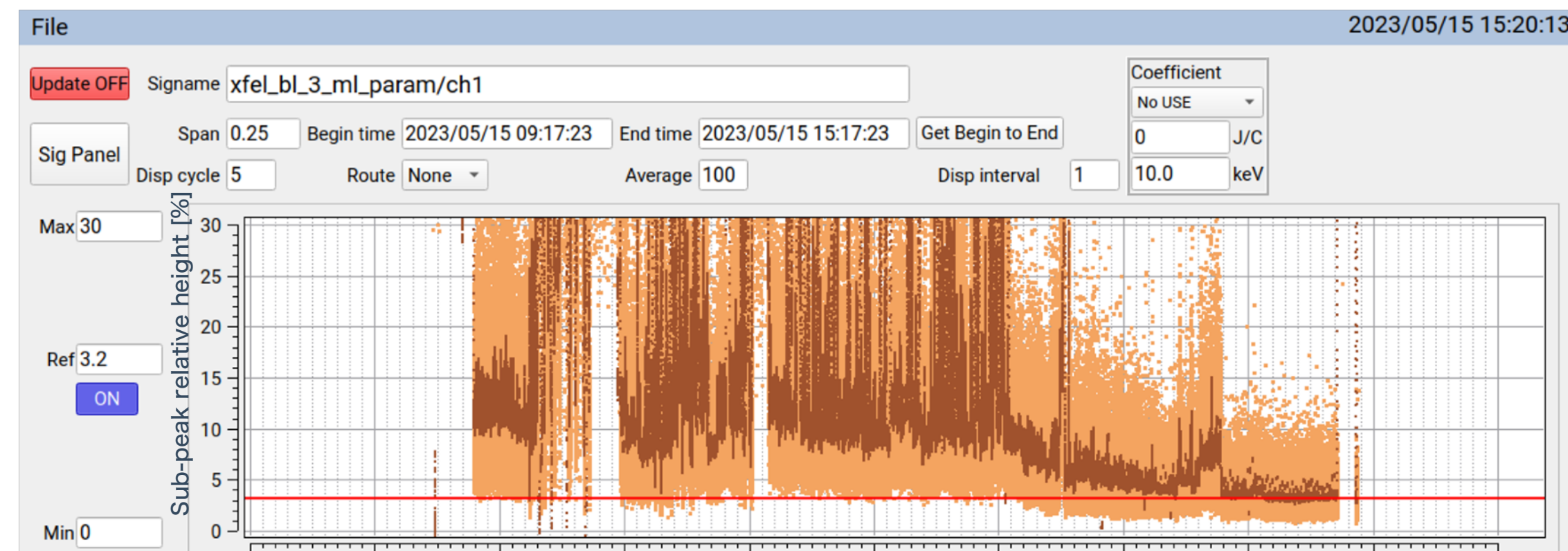
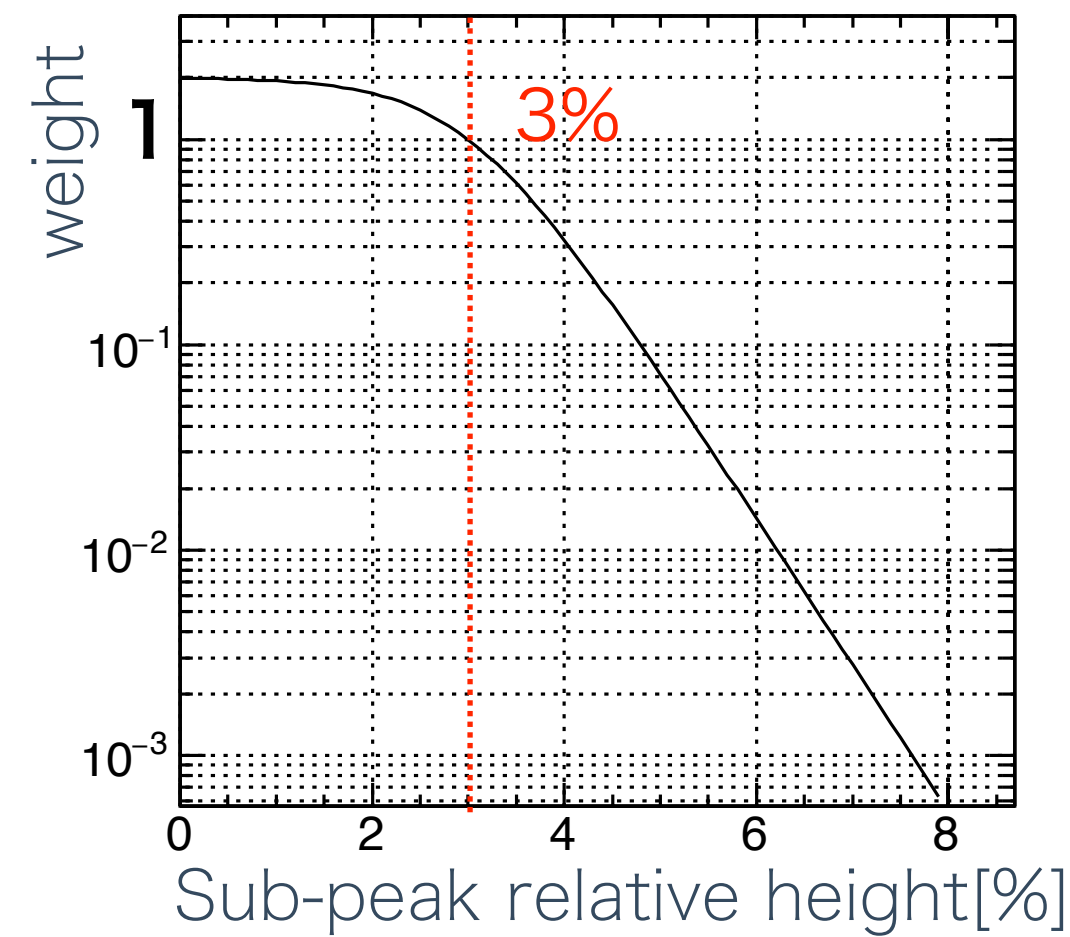

→ Tailor-made XFEL

Various optimization - XFEL spatial profile

- ▶ Another request from user: "Round spatial profile with single 'core'"
 - Double (or sometimes multiple-) "cores" often appear in spatial profile
 - Fit spatial profile with 2D gaussian (with single width; σ), and normalize the existing performance index with the (reduced) chi-square

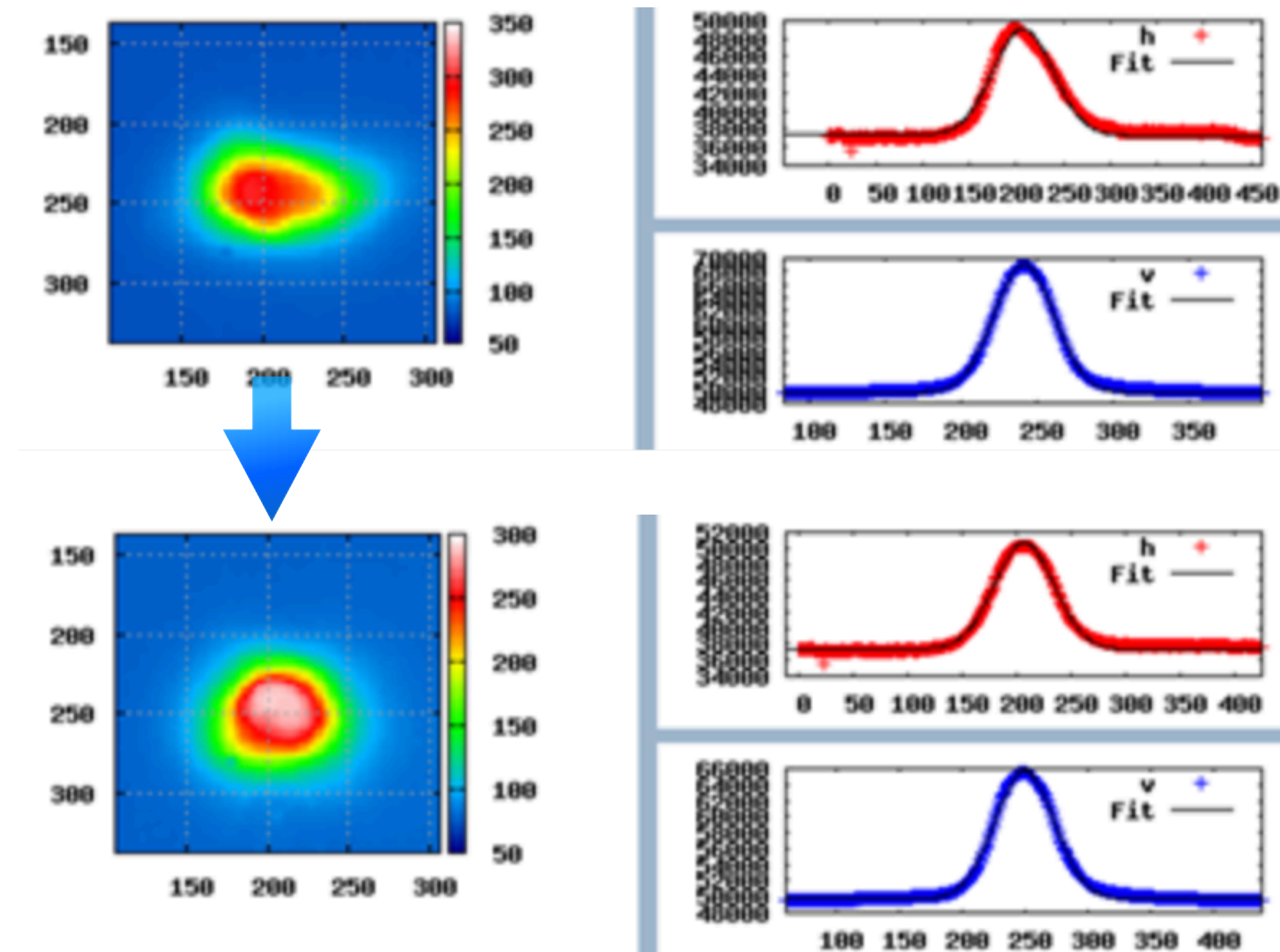
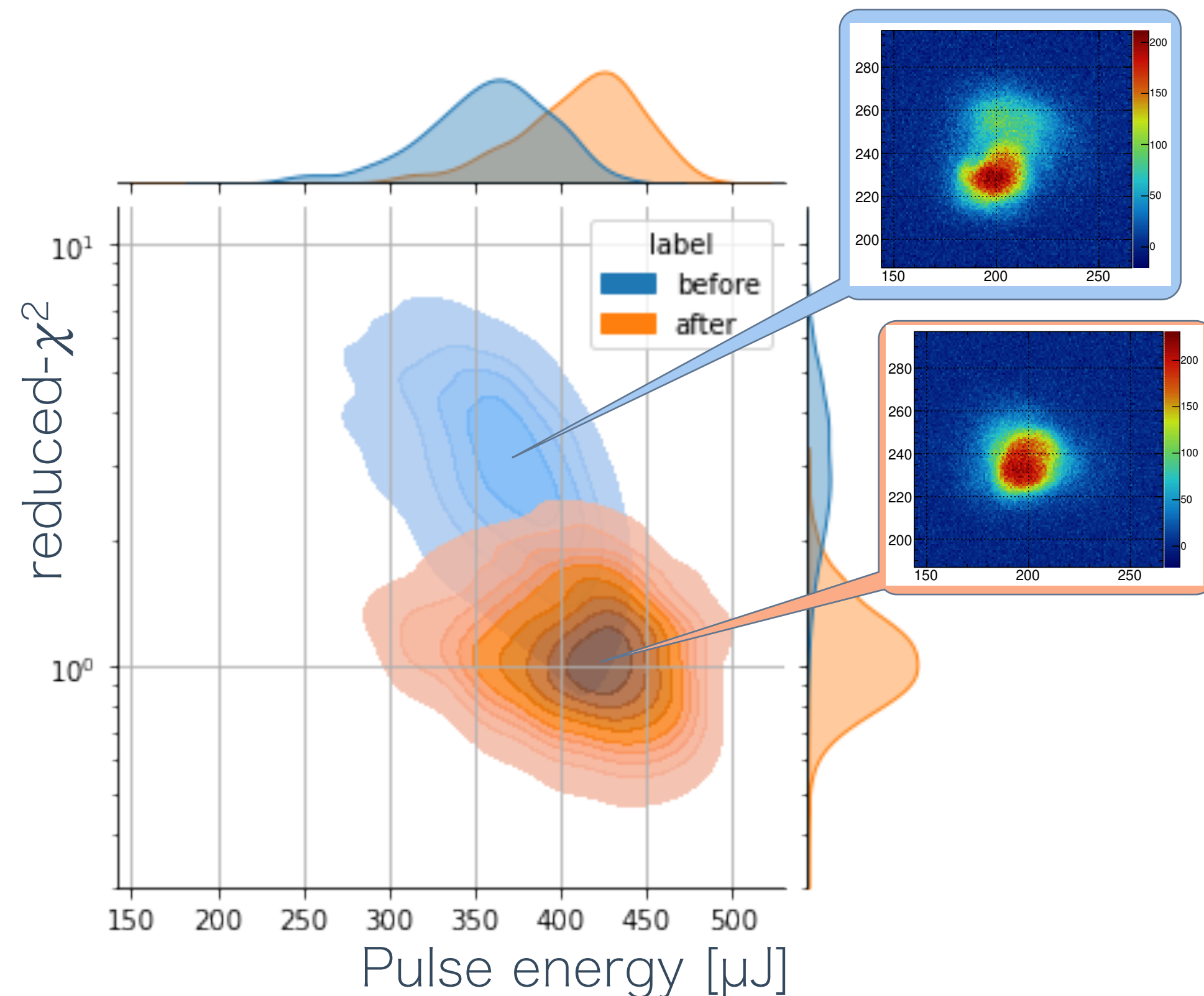

Various optimization - beam spatial profile

- ▶ Goal: Reproduce 6-D phase space in injection part
 - Rigorous and efficient reproduction of electron beam become even more critical especially after replacing thermionic gun cathode (e.g., velocity bunching w/ thermionic gun)
 - Existing method: 2D-profile or its projected image: manually checked by human eyes
- Evaluate multiple screens (+ wall current monitor) at a time to access to 6-D phase space information
- ➔ Begin with a spatial profile with a single screen-monitor
 - Test to restore parameters with given offsets at injection part
 - ✓ Successfully reproduce the initial profile; it seems to be more sensitive than the human eye

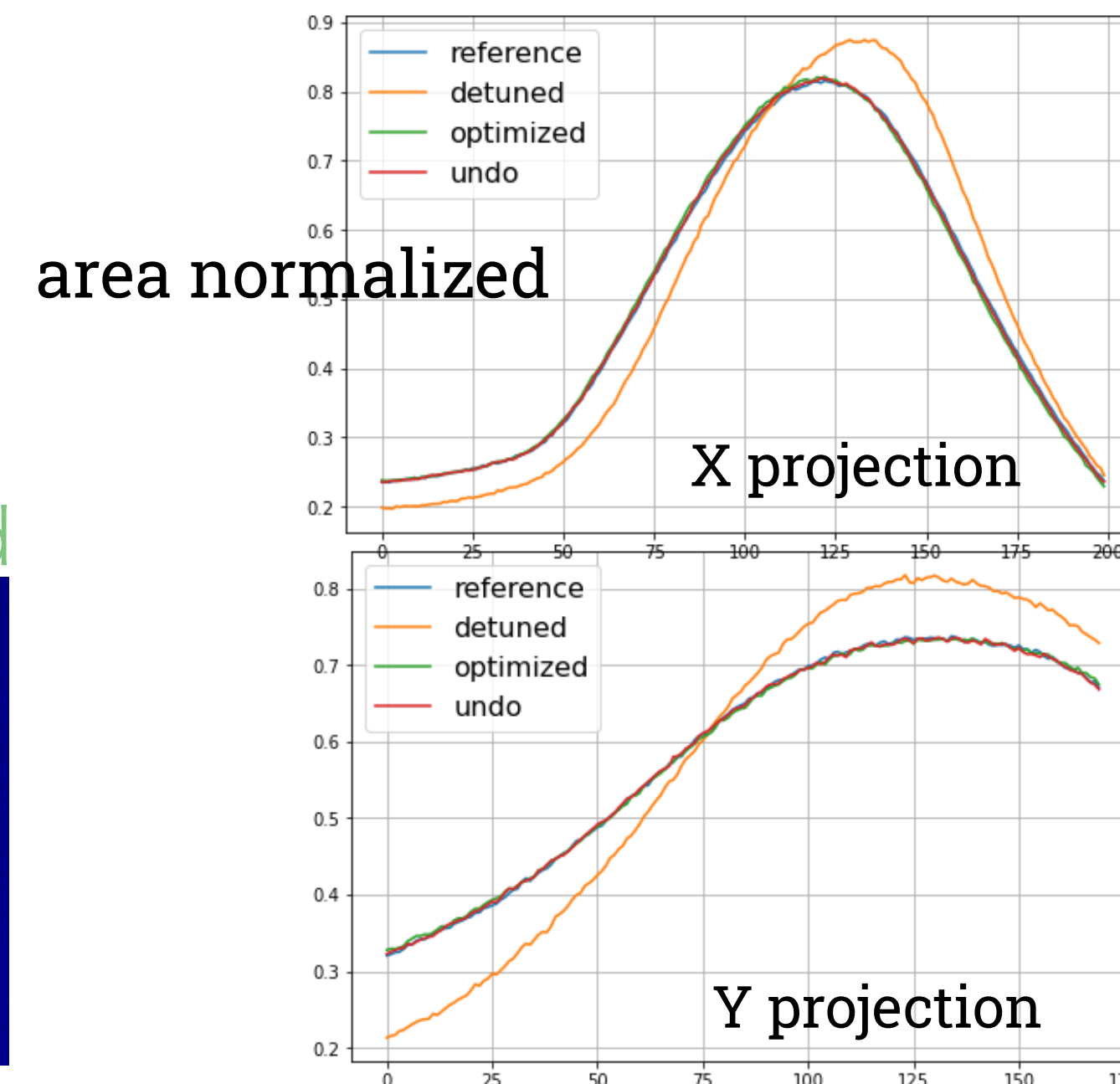
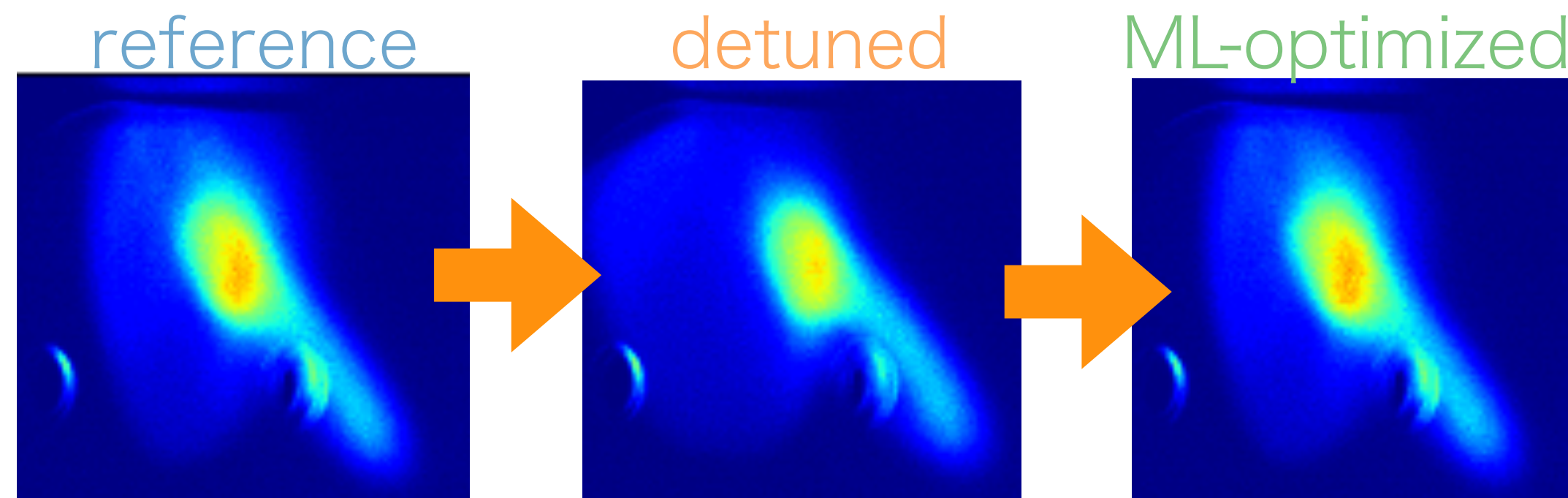
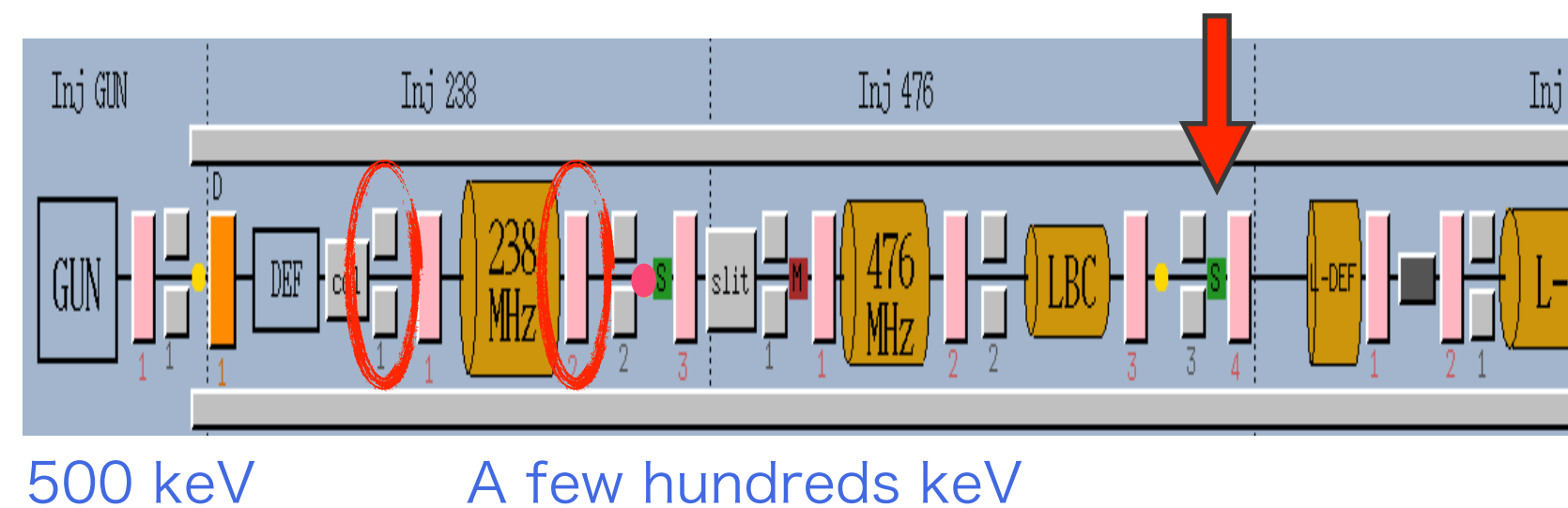

On-going efforts

N (Dimension)	V_Sphere / V_Cube	Center-to-Vertex
2	0.7854	1.41
3	0.5236	1.73
...
10	0.0025	3.16

Efficient initial sampling

- Range of each parameter is defined to have some sensitivity with just a single param
- As N increases, the distance to the vertices of the hyper-cube grows, and the volume ratio of hyper sphere/cube decreases rapidly
- Previous (2N+1): Cross-polytope vertices (2N) with $\pm 50\%$ on each axis + origin
 → New (N+2): Simplex vertices in a hyper sphere (N+1) + origin

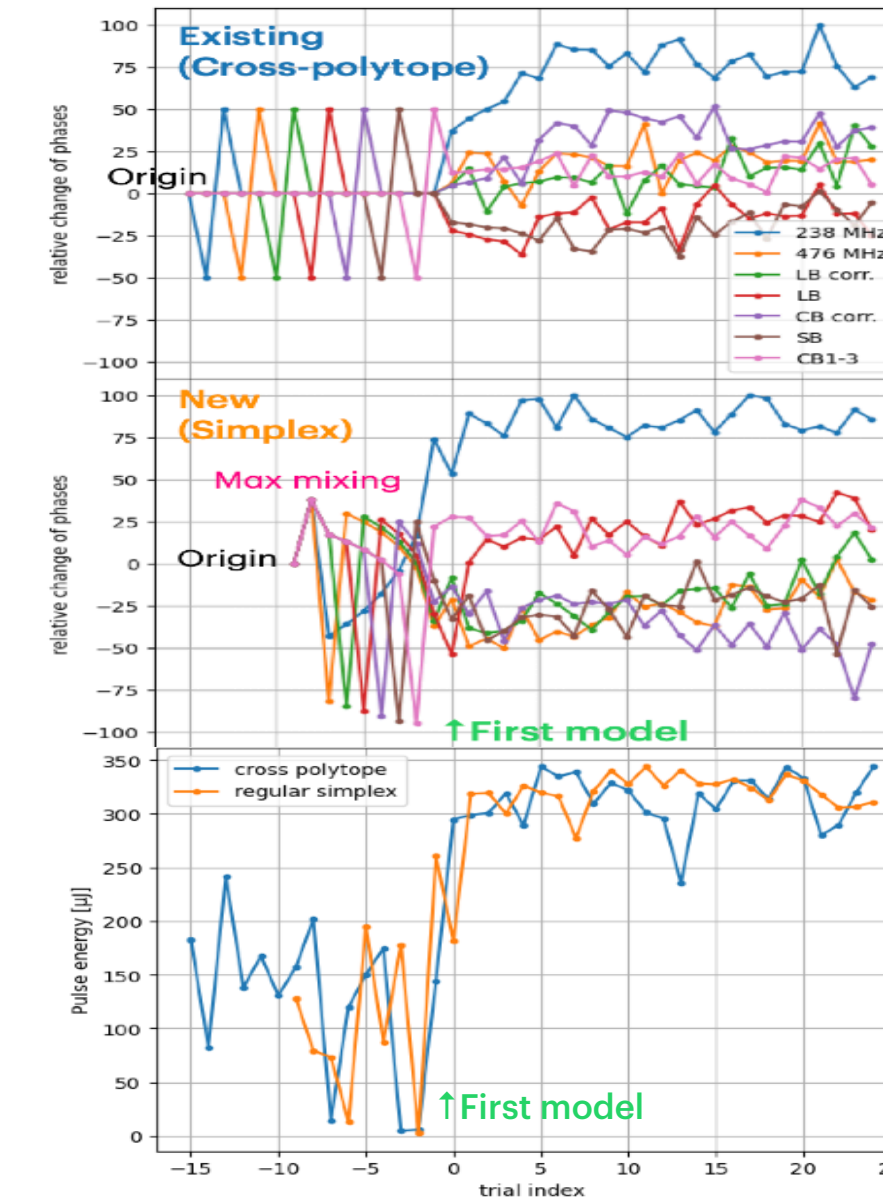
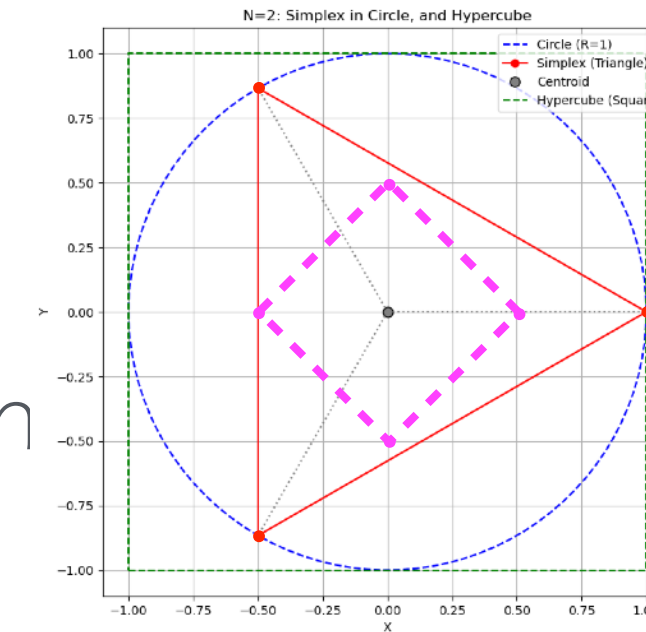

Introducing Time-varying (Non-stationary) BO to compensate for mid/long term drifts

- GP-BO with adding time axis as (N+1)th parameter
- Demo: 1D-gauss /w time varying mean + dummy parameter

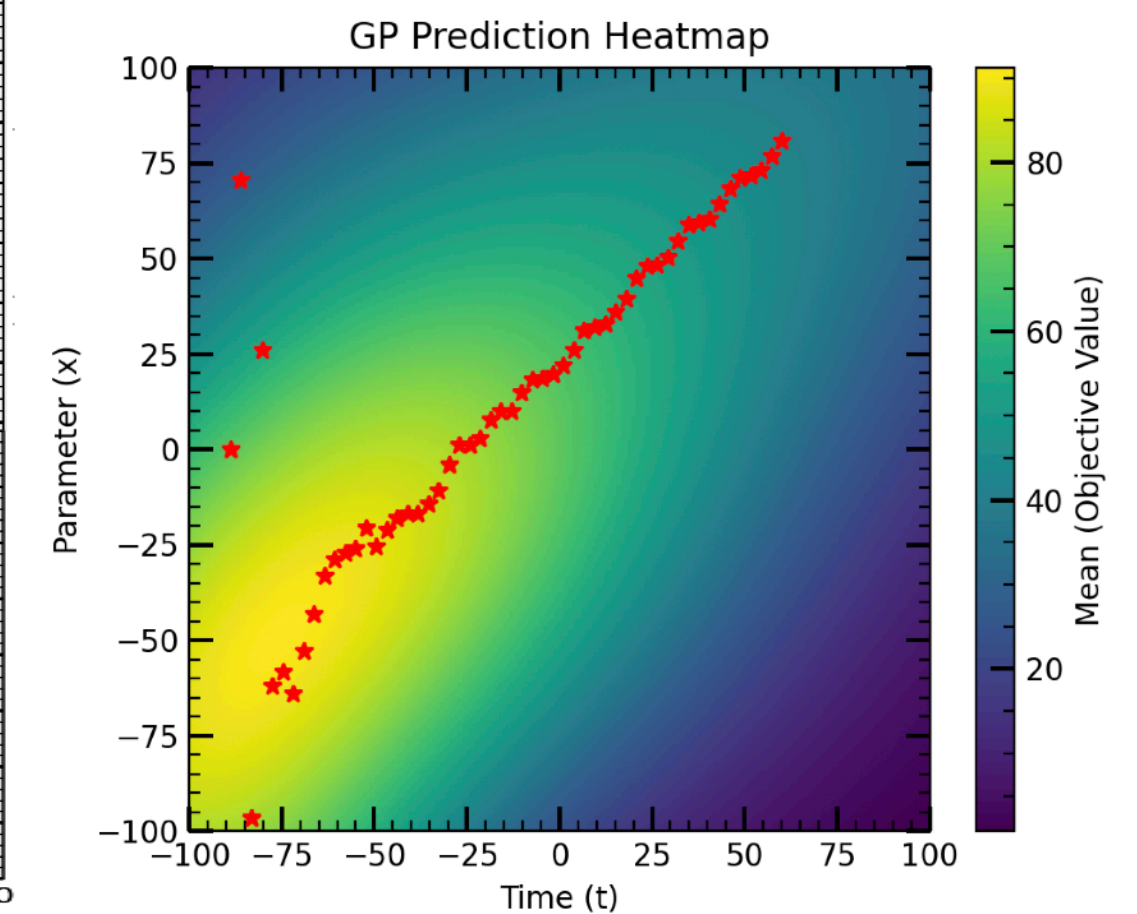
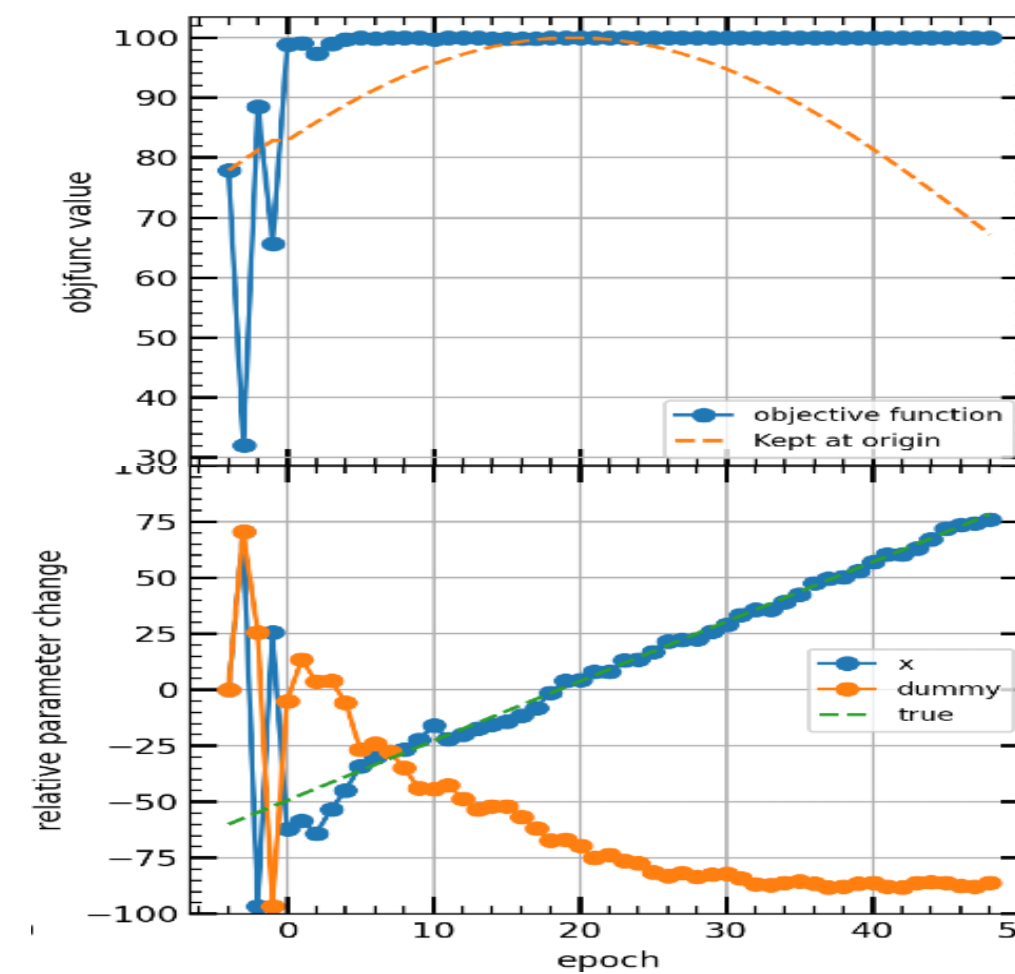
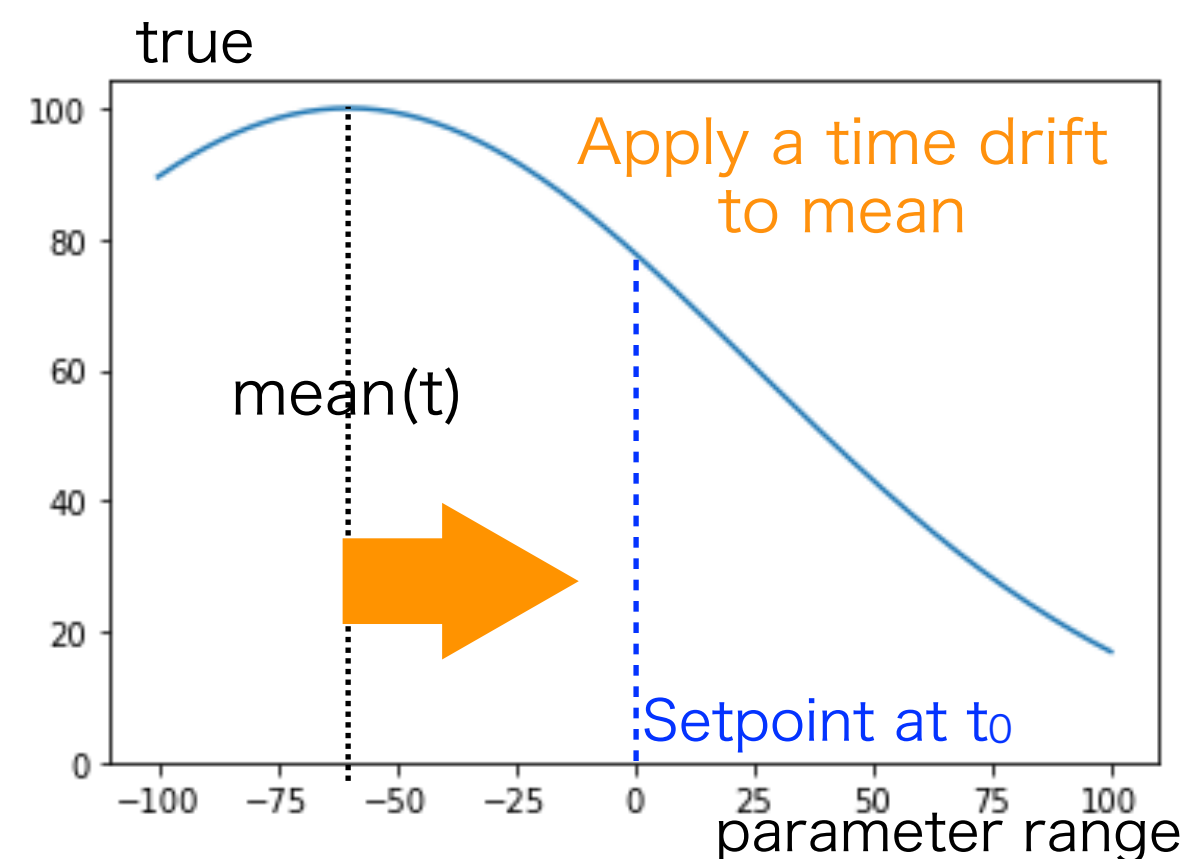

System implementation

▶ Stabilizing XFEL

- By newly introduced FB for bunch current after the collimator, getting more stable
 - FB for cathode emission current had already existed, and now drift on beam focussing is corrected by adjusting magnetic-lens before the collimator
 - Surface of the gun cathode keeps slightly changing as emitting the current
 - By keeping the bunch current constant, and suppressing the effect on CSR monitor, the bunch compression at each chicane can be compensated correctly.

➔ Well-tuned XFEL can be delivered to user's experiments (even with tiny sweet-spot)

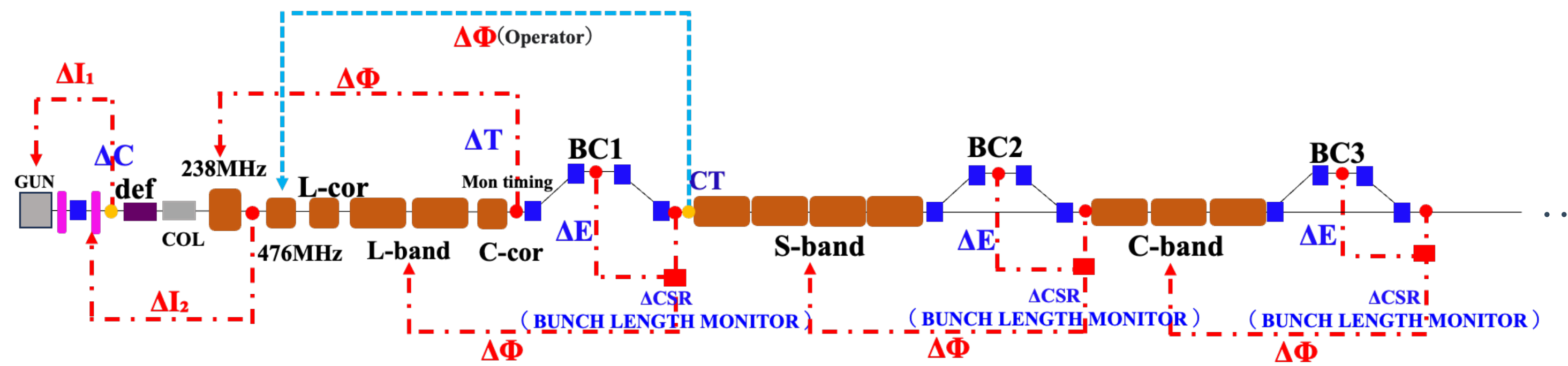
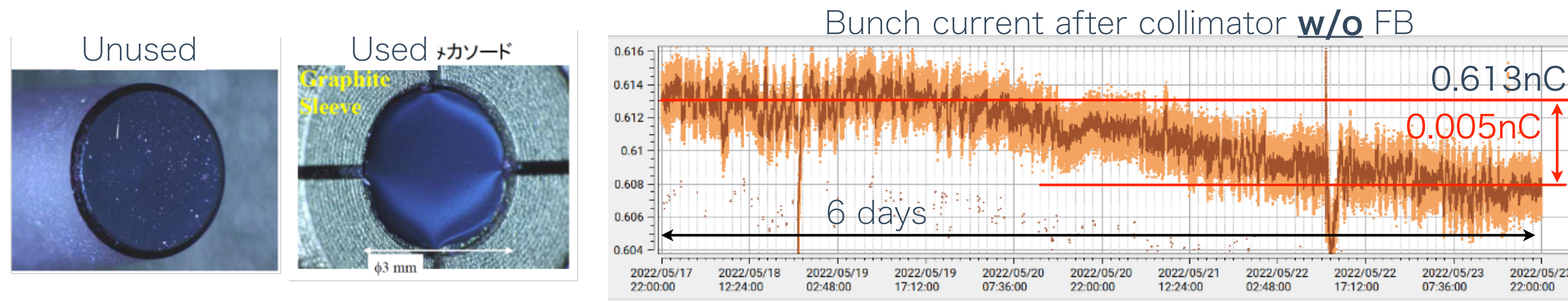

System implementation

▶ Stabilizing XFEL

- By newly introduced FB for bunch current after the collimator, getting more stable
 - FB for cathode emission current had already existed, and now drift on beam focussing is corrected by adjusting magnetic-lens before the collimator
 - Surface of the gun cathode keeps slightly changing as emitting the current
 - By keeping the bunch current constant, and suppressing the effect on CSR monitor, the bunch compression at each chicane can be compensated correctly.

➔ Well-tuned XFEL can be delivered to user's experiments (even with tiny sweet-spot)

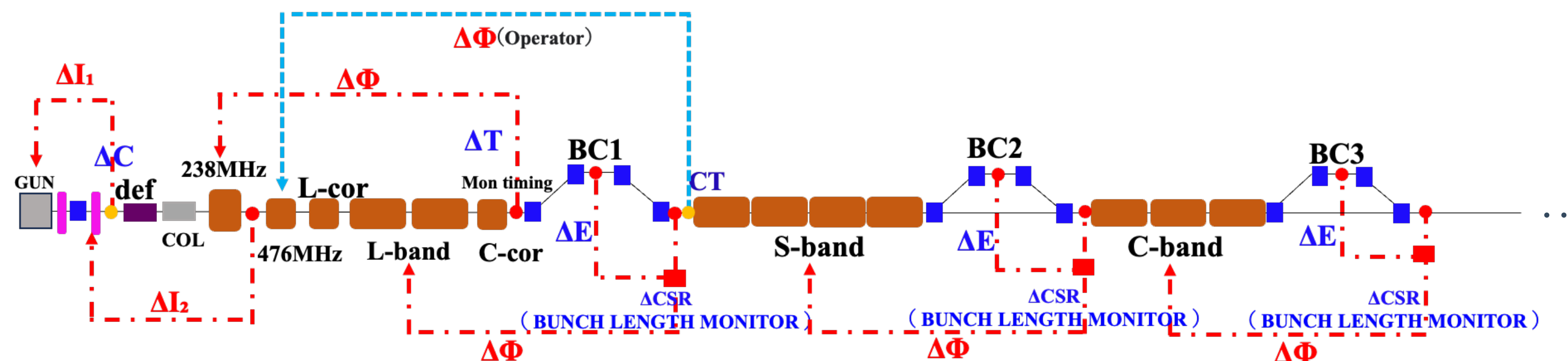
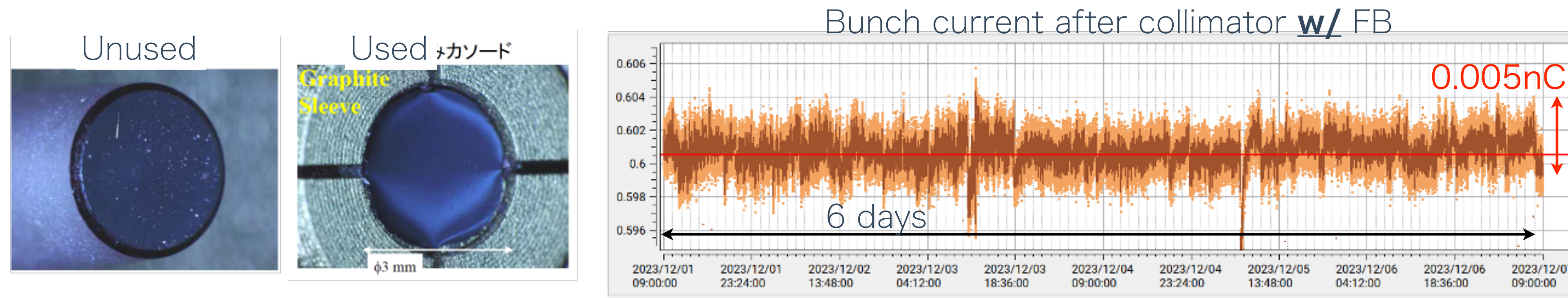

System implementation

▶ Stabilizing XFEL

- By newly introduced FB for bunch current after the collimator, getting more stable
 - FB for cathode emission current had already existed, and now drift on beam focussing is corrected by adjusting magnetic-lens before the collimator
 - Surface of the gun cathode keeps slightly changing as emitting the current
 - By keeping the bunch current constant, and suppressing the effect on CSR monitor, the bunch compression at each chicane can be compensated correctly.

➔ Well-tuned XFEL can be delivered to user's experiments (even with tiny sweet-spot)

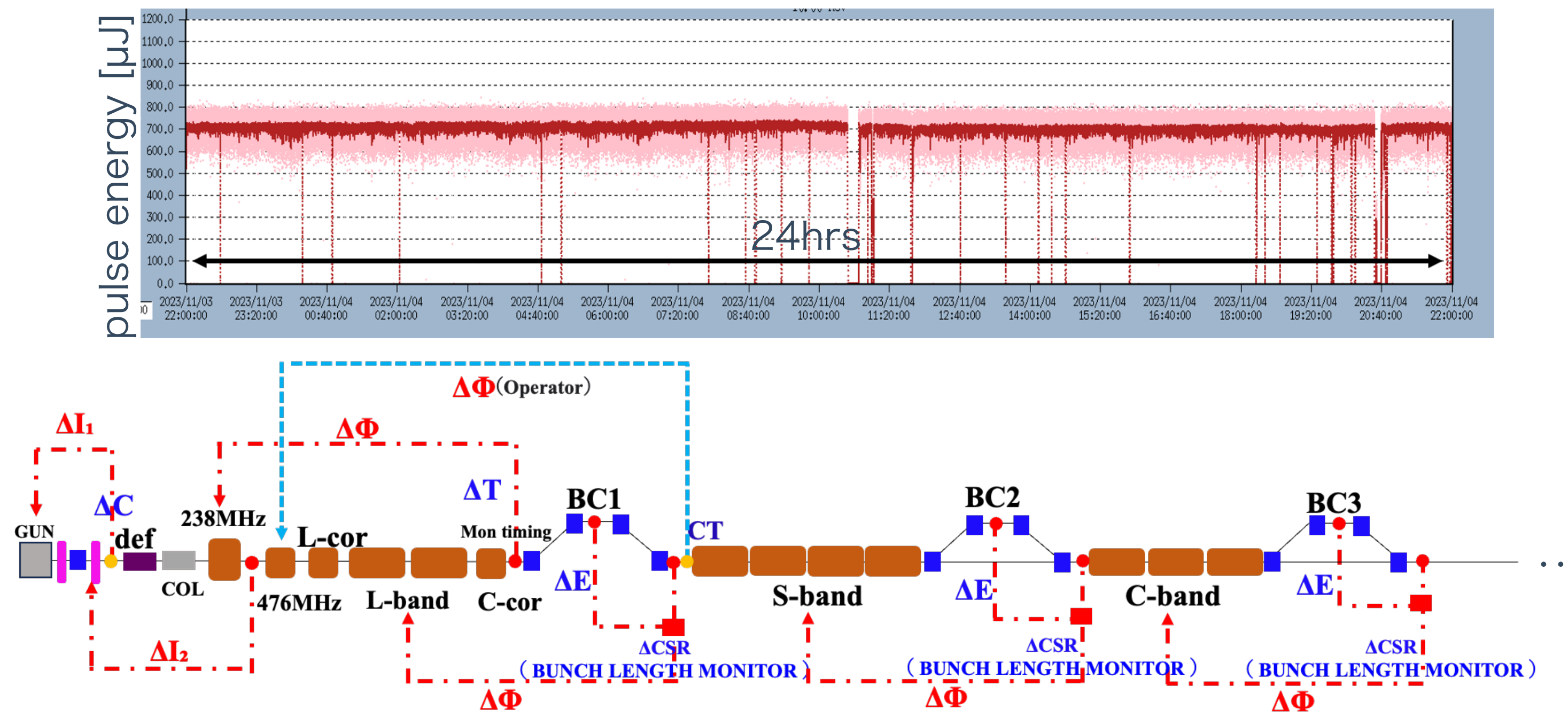

System implementation

- ▶ Loosely coupled design and implementation
 - Synergy of Object-Oriented and Layered-Architecture
- ➔ Tailor-made dedicated GUI implemented by the operators

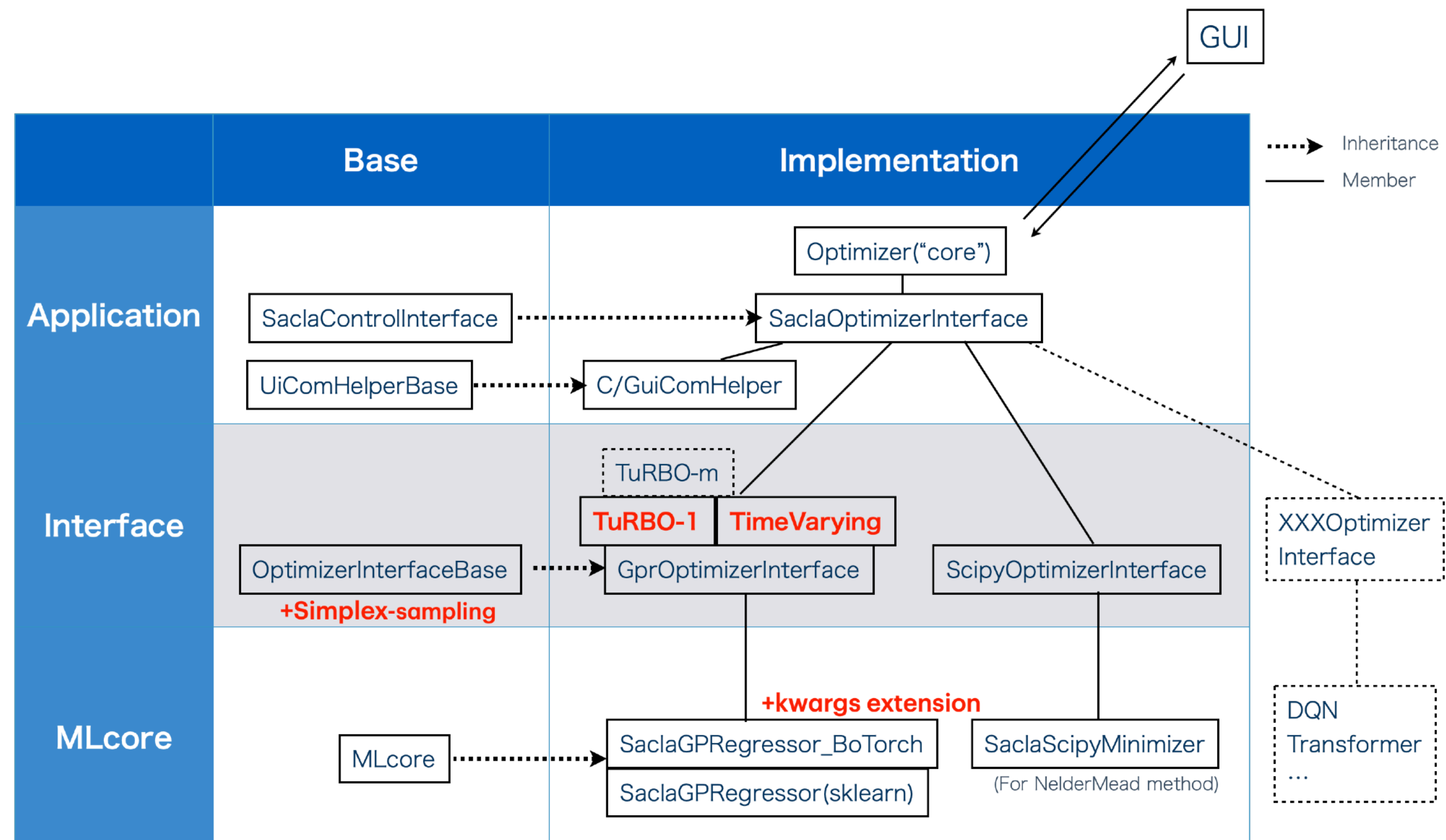

Schematic of GP-optimizer implementation

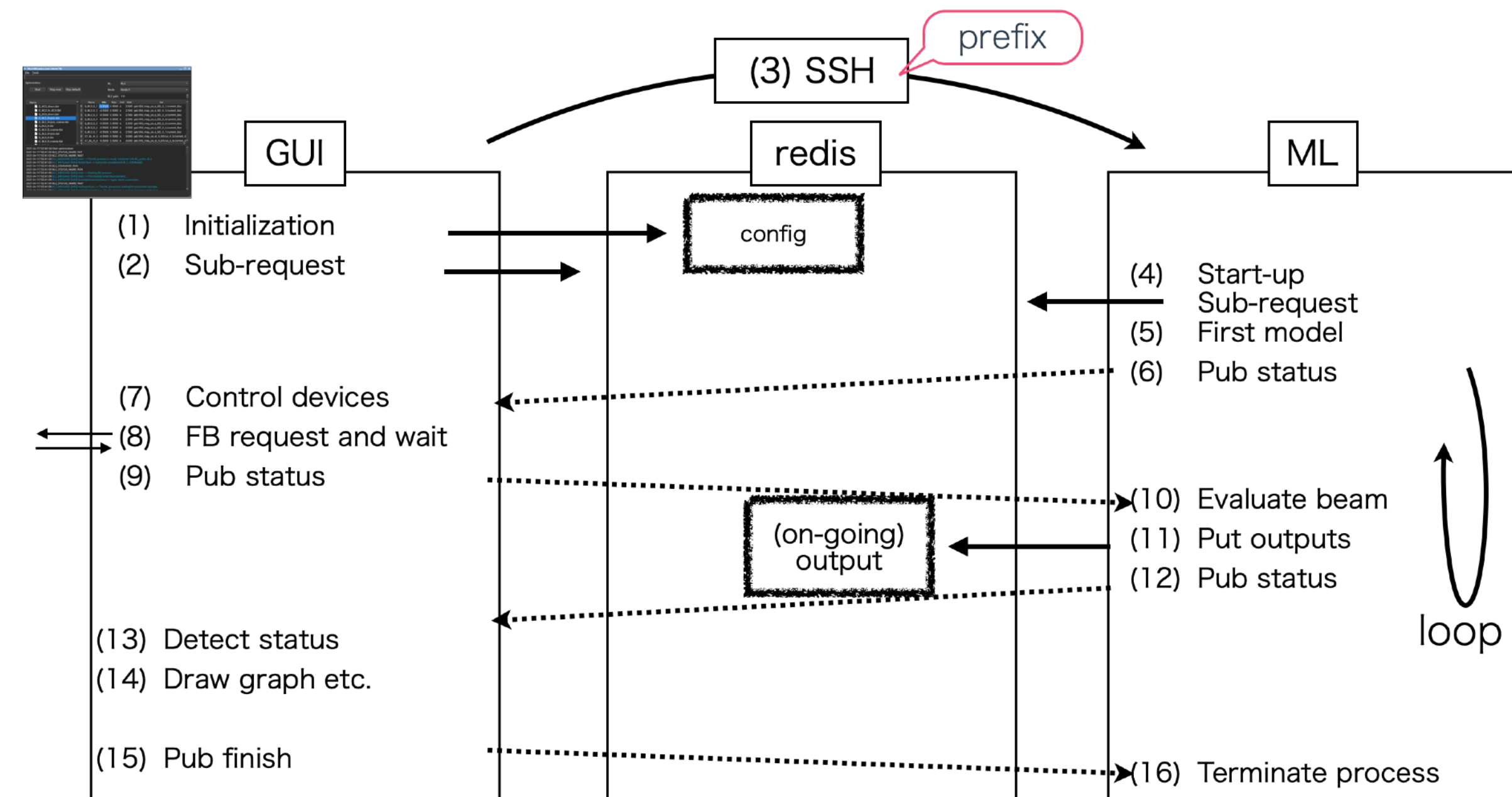

Schematic of GUI-ML communication

System implementation

- ▶ Tightly coupled user collaboration
 - Ex: spectral brightness or shape optimization
 - A new spectrometer with enough resolution to measure s-by-s pulse-width online

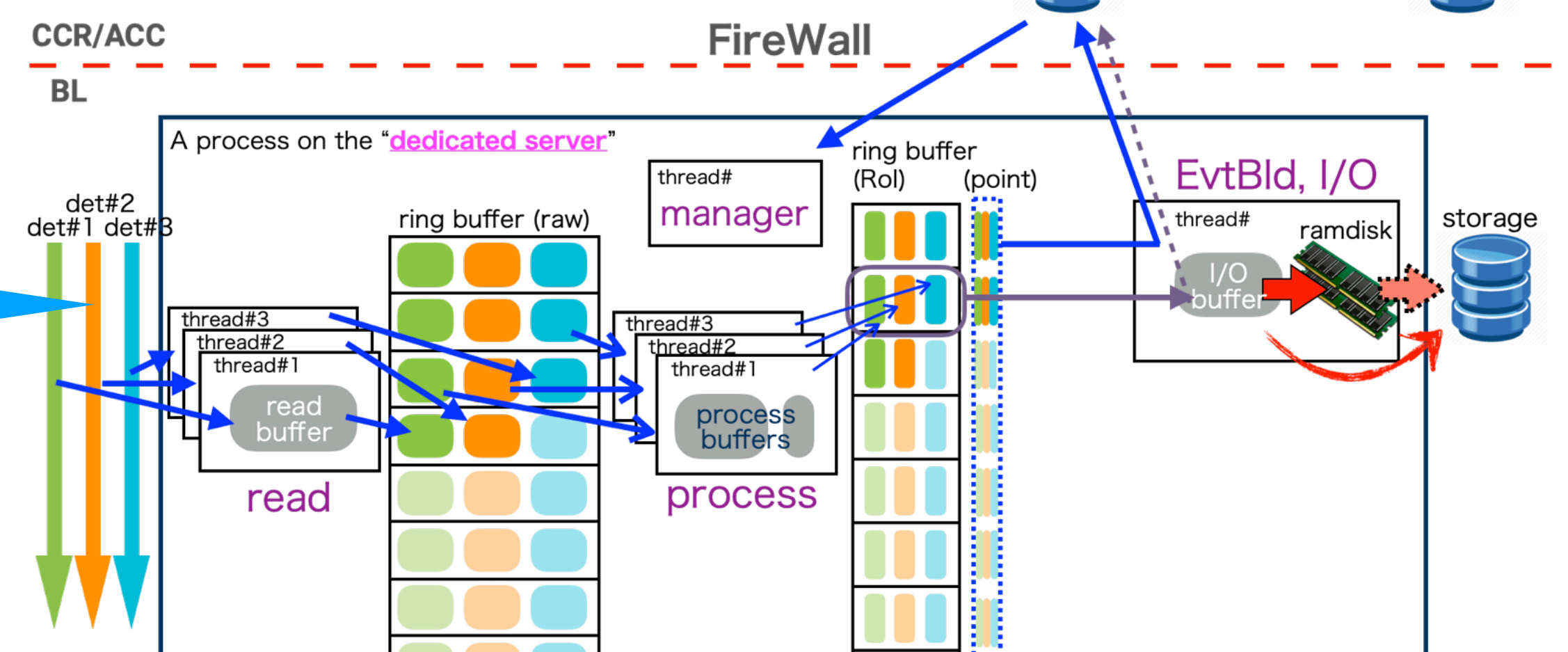
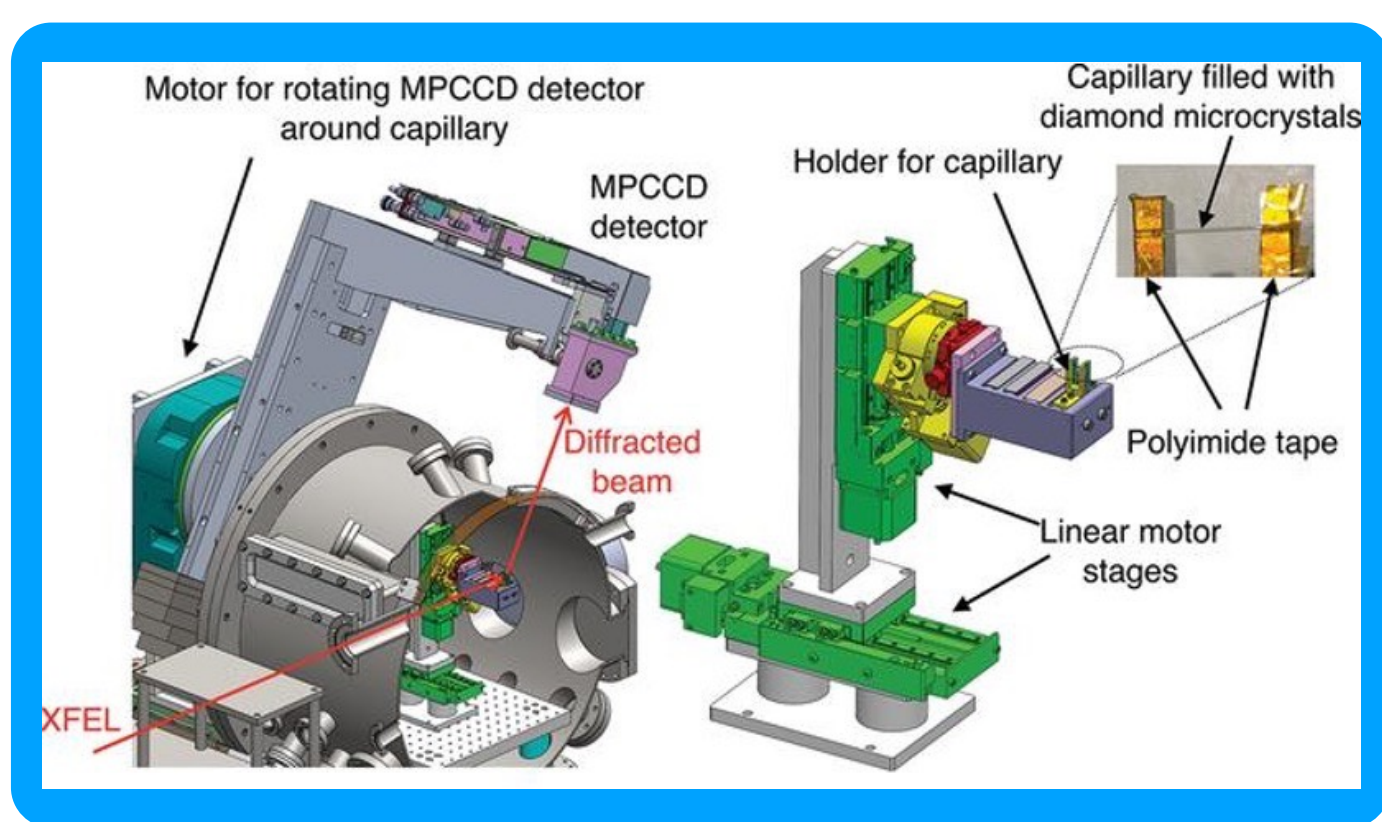
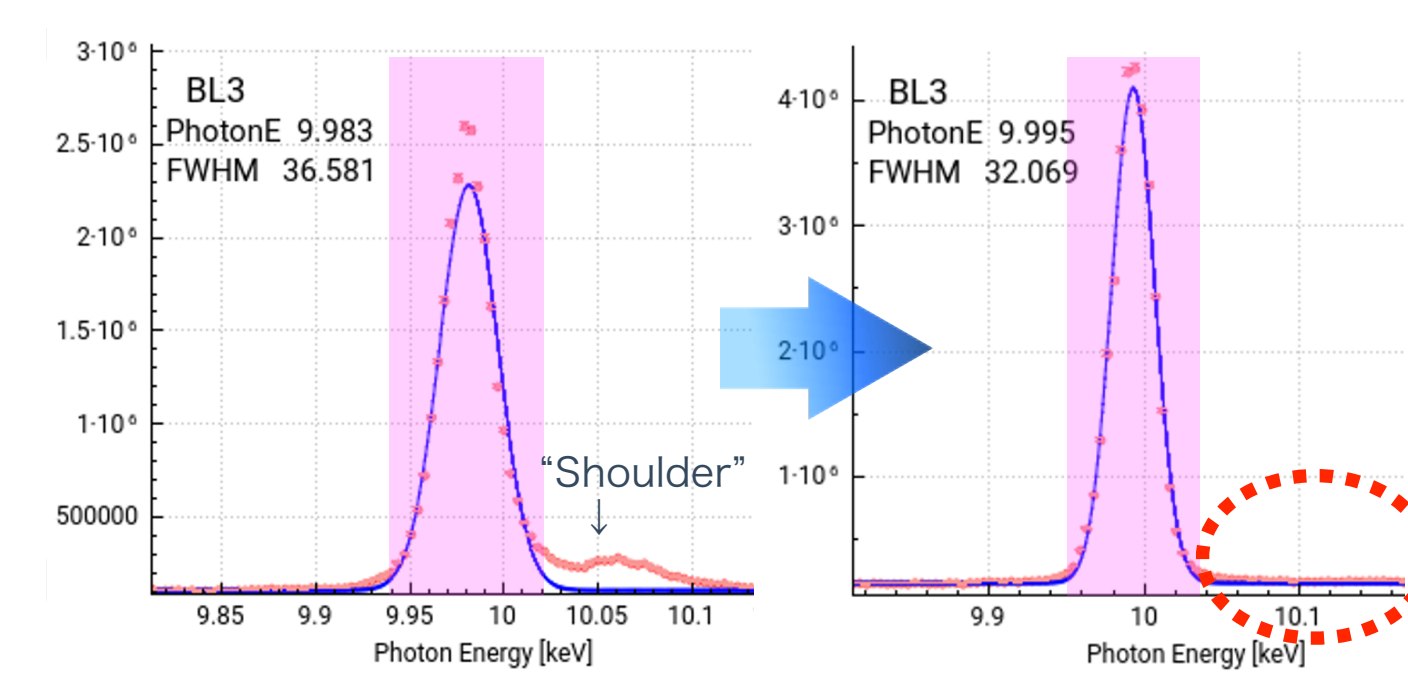
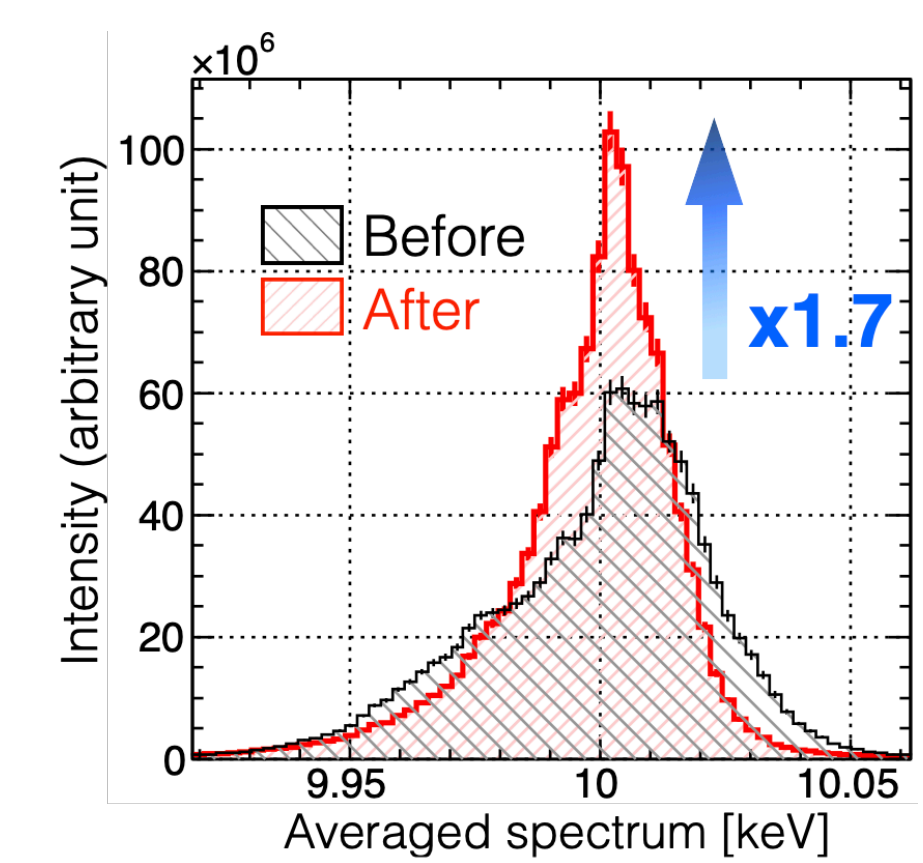
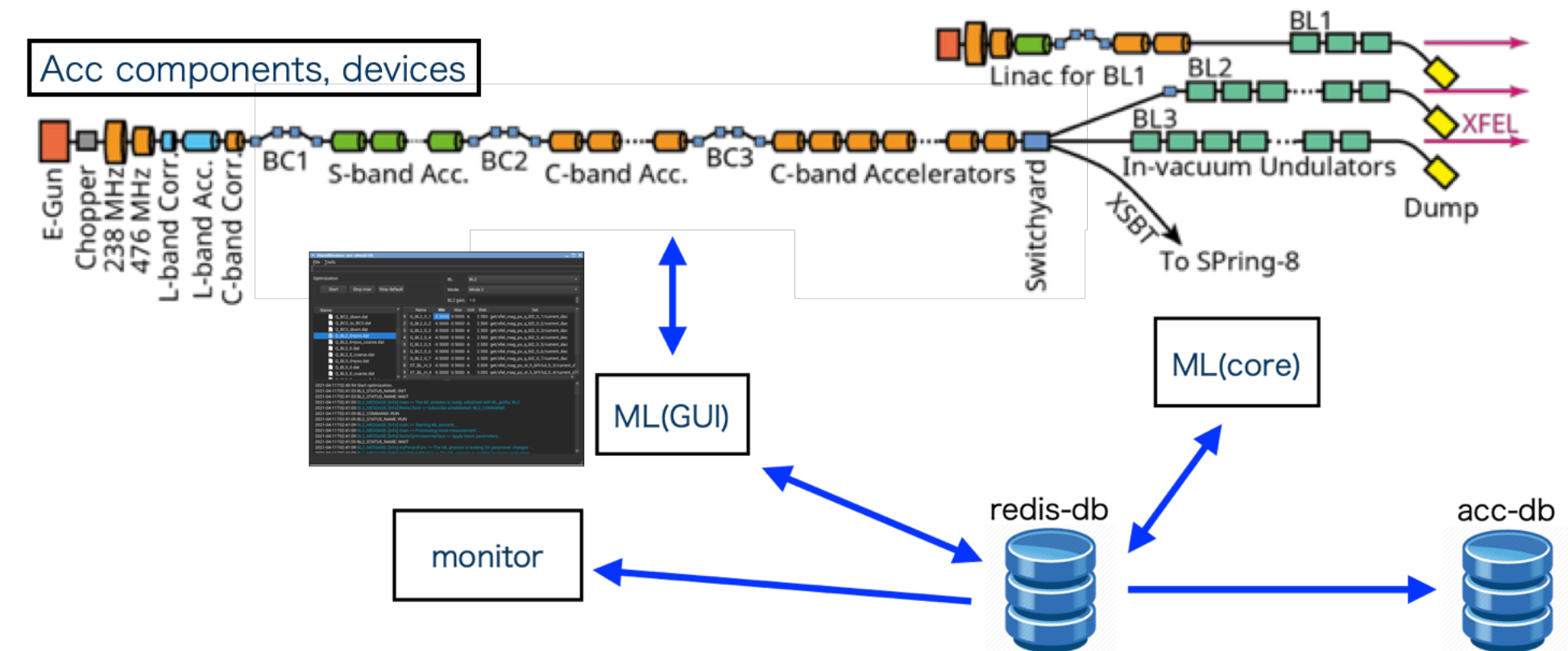

System implementation

- ▶ Stabilizing XFEL; Focus on Hardware Stability and Physical Understanding
 - To have better consistency and reproducibility during optimization

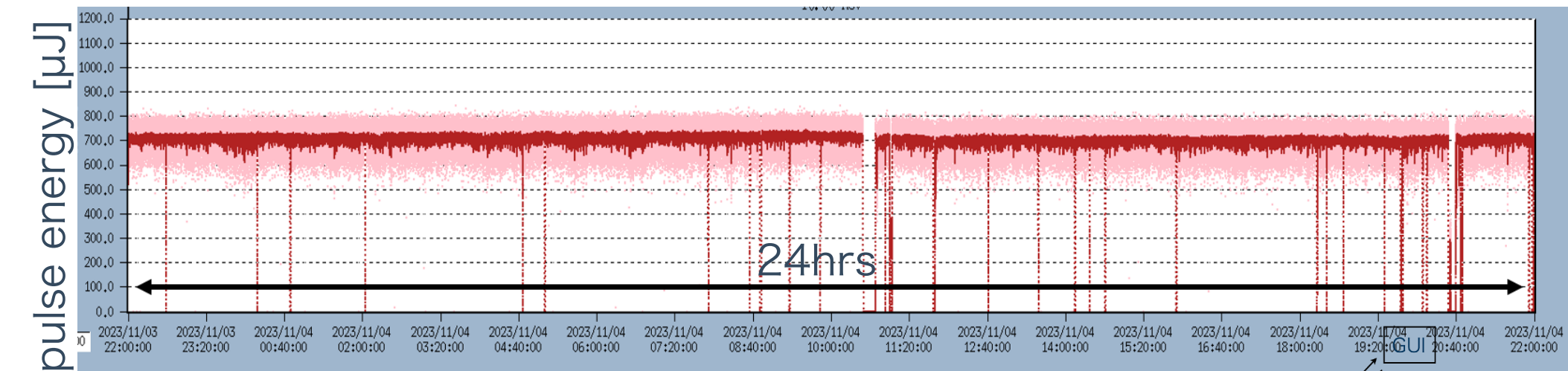

- ▶ Loosely coupled design and implementation
 - Synergy of Object-Oriented and Layered-Architecture
 - To have better scalability and flexibility

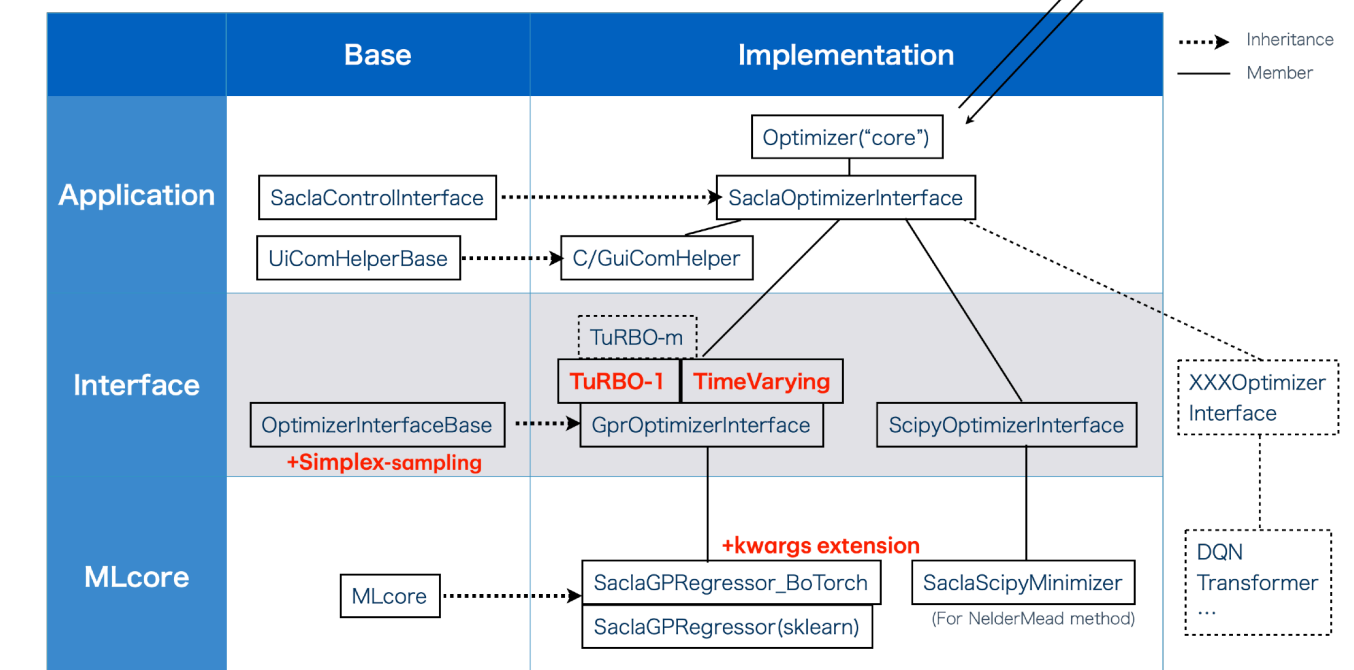

- ▶ Tightly coupled user collaboration
 - To maximize science output as a user facility

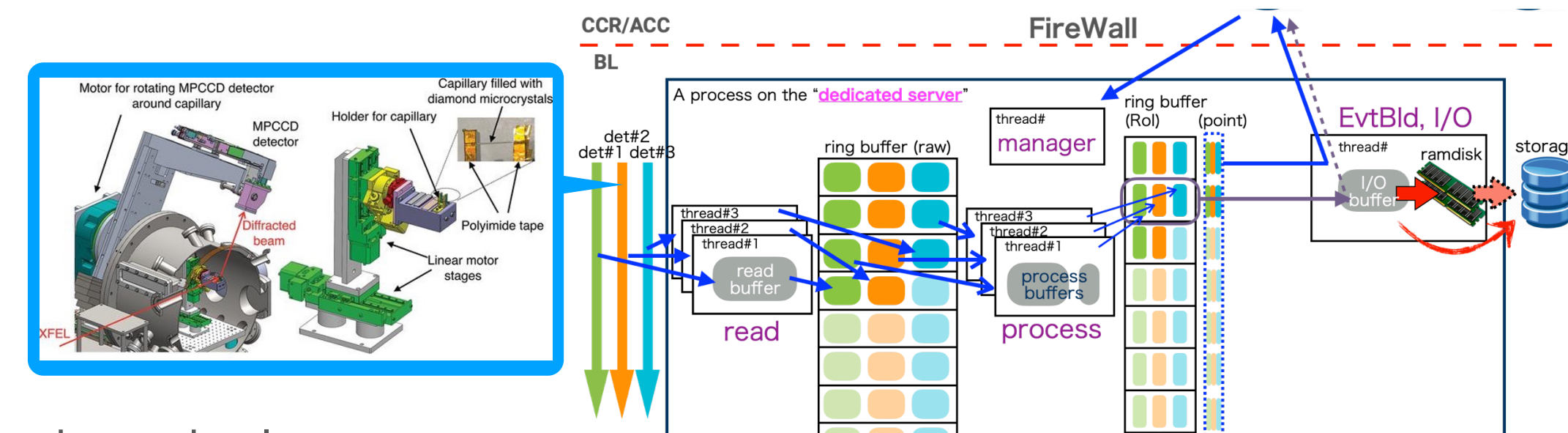

➔ A 'must-have' tool for operators, deeply integrated into the daily operations

"Simplicity is the ultimate sophistication."

— Leonardo da Vinci

Prospects

- ▶ Research and development on X-band deflector and its related components are on-going.
 - To get information of bunch length and compression as input
 - 1 fs resolution
- ➔ Access to longitudinal info by fully utilizing AI/ML

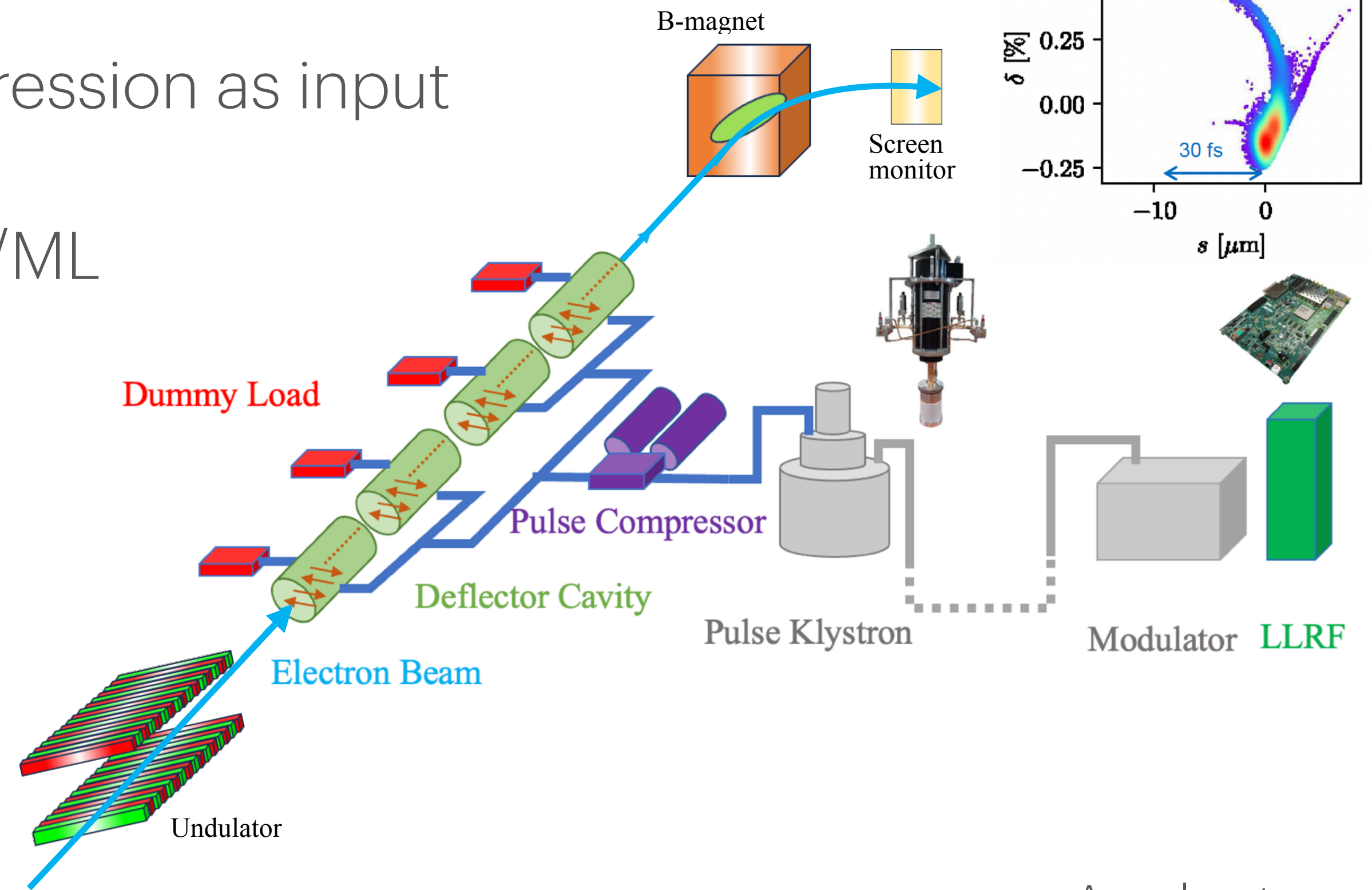

H. Maesaka, et.al., PRAB 21, 050703 (2018)

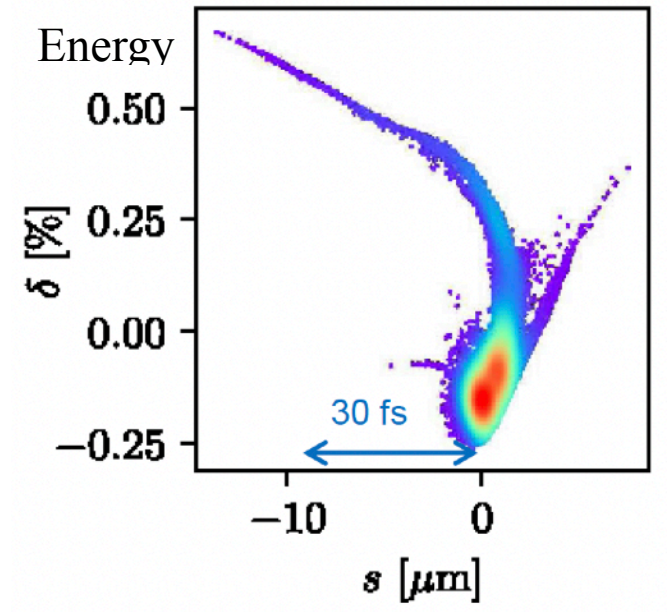

- ▶ Also start considering of introducing Agent-AI to machine tuning and operation



Summary

- * Introduce ML-driven beam tuning to get better XFEL performance and rationalize accelerator operation at SACLA/SPring-8
 - Pulse-by-pulse operation and beam injection to SPring-8 SR
 - Bayesian optimization based on Gaussian Process Regression
 - Deeply integrated into practical use for the daily operations
- * Optimization for various experiments and requirements
 - XFEL monitor data to accelerator side (raw, pulse-by-pulse)
 - SASE, self-seeding, two-colored ...
 - Spectral brightness
 - Spectral shape (suppress shoulder/sub-peak)
 - XFEL spatial profile
 - Reproduction of electron beam spatial profile → 6-D phase space in injector part
- * Prospect
 - Introduce X-band deflector to tune bunch length and compression
 - Preparing the Ground for Autonomous Intelligence; start considering of introducing Agent-AI to machine operation

Thank you for your attention!

- ▶ Special thanks to ...
 - SACLA beamline group: Daily stable operations and development of related GUIs
 - SPring-8 Service Co., Ltd.: Introducing permanent, high-precision online diagnostics
 - My colleagues in RF team: Invaluable support in daily research