



**UNIVERSITY
OF OSLO**

MOI1T02 Linear collider studies and prospects

Outline

- LC physics programme and technology options
- Linear Collider with NCRF or SCRF technologies; CLIC, ILC Japan, SCRF version at CERN
- Implementation at CERN: civil engineering, cost and schedule
- R&D programmes and upgrade paths
- Next steps and a conclusion

Steinar Stapnes – University of Oslo
IPAC 2026

A physics-driven, polarised operating scenario for a Linear Collider

Stage 1: 250-380 GeV

- precision Higgs mass and total $\sigma(\text{ZH})$
- precision Higgs couplings and total width to % level
- resonance/compositeness search in $ff\text{bar}$, WW to 10's TeV
- 1-yr excursion to the Z pole - $\sin^2\theta_W$ to $3e-6$

Stage 2: 550 GeV

- precision Higgs couplings and total width to sub-% level
- top quark Yukawa to 3%, Higgs self-coupling to 11%
- top quark electroweak couplings to 0.1%
- resonance/compositeness search in $ff\text{bar}$, WW to 50 TeV
- 1-yr excursion to the $t\text{tbar}$ threshold - m_t to 40 MeV

Higher energies: 1000 GeV or above

- top quark Yukawa to 1%, Higgs self-coupling in WW fusion
- Higgsino search to 500 GeV
- follow up HL-LHC discoveries of new Higgs and electroweak states

Fixed target program: dark sector, nonlinear QED

The projections are supported by full-simulation studies with detailed detector designs and machine bkgds.

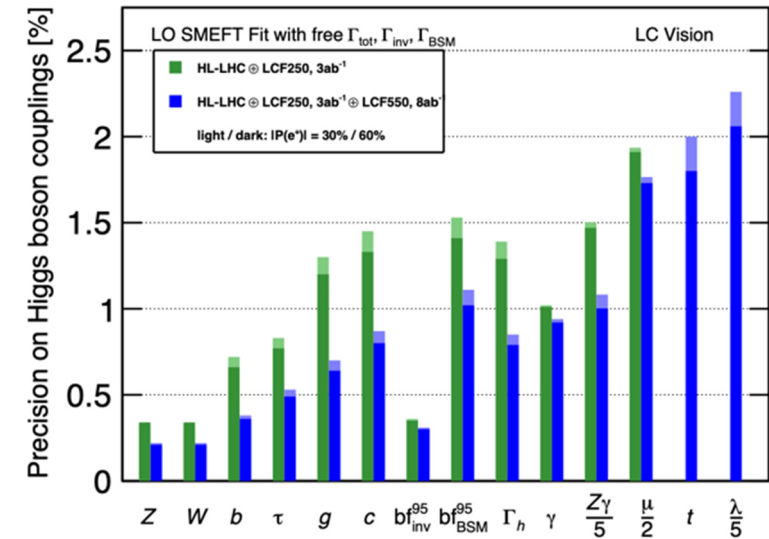

All discoveries of deviations from the SM can be verified in complementary reactions at higher energy, e.g. H self-coupling visible in two complementary HH production rxns.

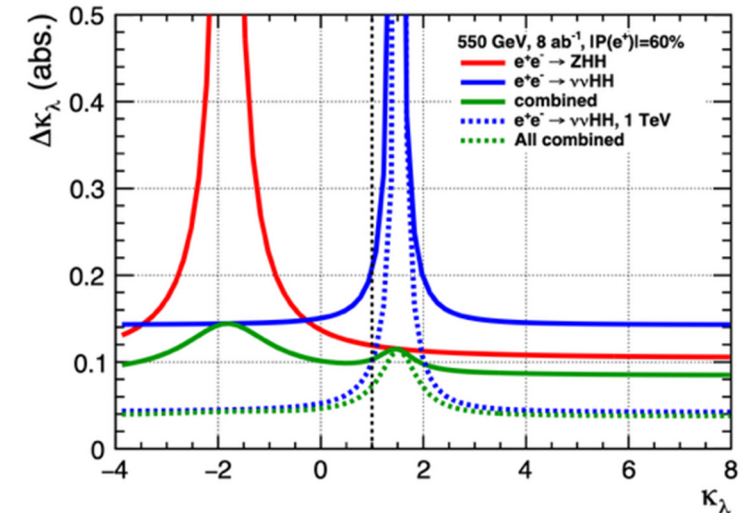

WW fusion
ZHH
Combined

Linear Colliders: from “construction-ready” to R&D

- **International Linear Collider (ILC)**
 - superconducting RF 31-35 MV/m
 - proven technology: Eu.XFEL, LCLS-II, SHINE, ...
 - up to 1 TeV, both beams polarised
 - since 2012 considered for construction in Japan
- **Compact Linear Collider (CLIC):**
 - beam-driven warm copper RF, 70-100 MV/m
 - up to 3 TeV, electrons polarized
- A vast number of other ideas / R&D programs
 - Improved SCRF or NCRF
 - C3: cool copper collider up 150 MV/m
 - HELEN: advanced SCRF up to 70 MV/m
 - ReLiC / ERLC: energy & particle recovery
 - HALHF: hybrid asymmetric linear Higgs factory
 - ALEGRO: 10 TeV PWA $ee / \gamma\gamma$
 - XCC: XFEL-driven $\gamma\gamma$ collider
 -

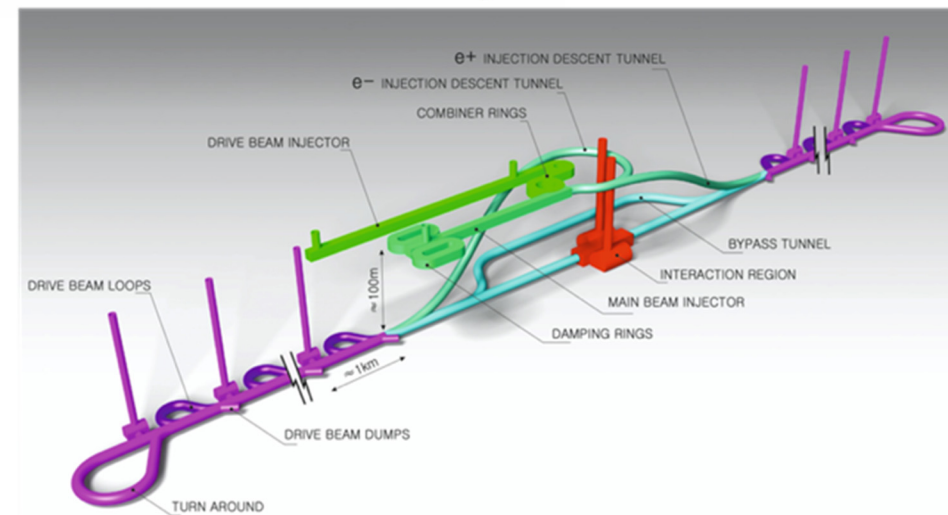
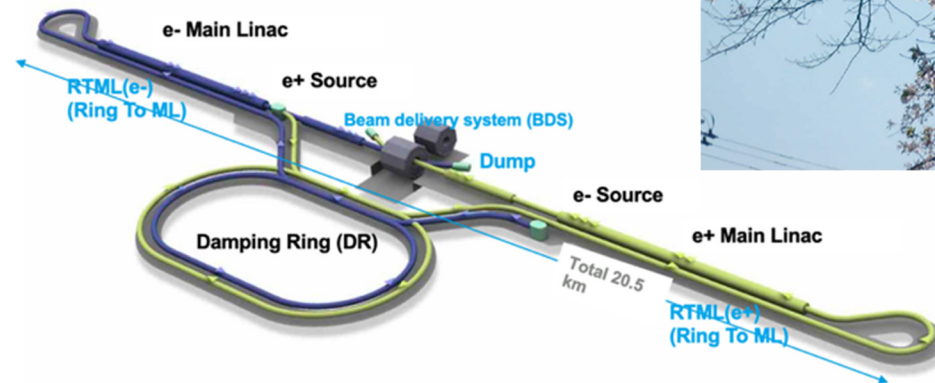

The Compact Linear Collider (CLIC)

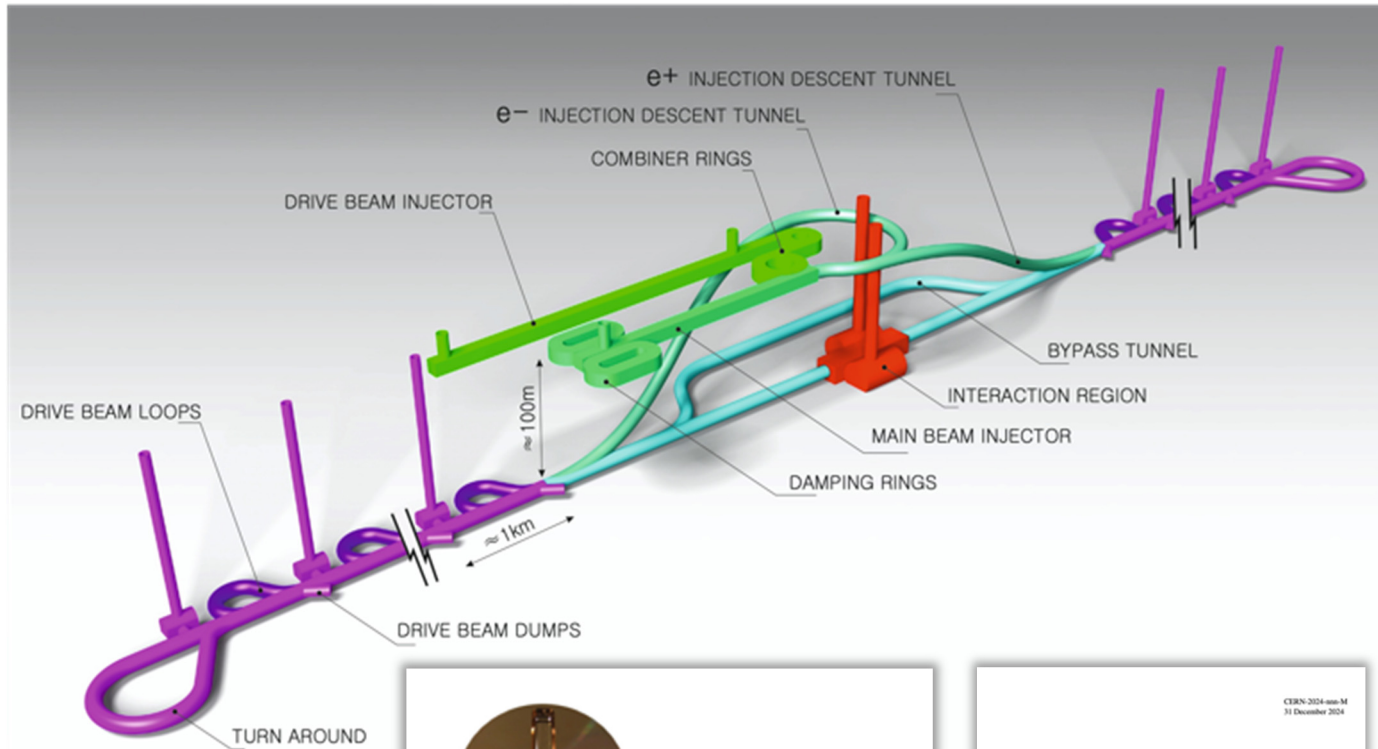

Accelerating structure prototype for CLIC: 12 GHz ($L \sim 25$ cm), 100 MV/m

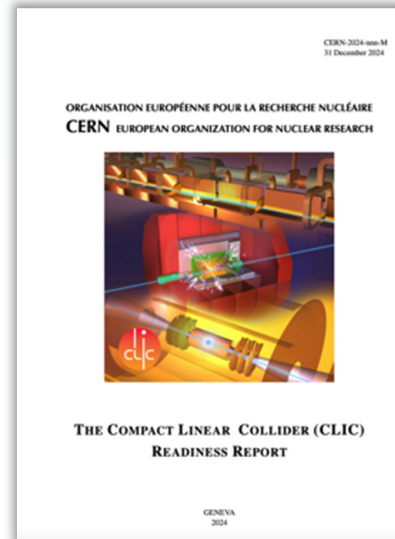

- Timeline: Electron-positron linear collider at CERN for the era beyond HL-LHC
- Compact: Novel and unique two-beam accelerating technique with high-gradient room temperature RF cavities ($\sim 20'500$ structures at 380 GeV), ~ 11.5 km in its initial phase
- Expandable: Staged programme with collision energies from 380 GeV (Higgs/top) up to 1.5 TeV
- CDR in 2012 had focus on 3 TeV. Project Implementation Plan in 2018 with focus in 380 GeV
- Readiness Report submitted for the ESPP with focus 380 GeV for Higgs and top, upgradable to 1.5 TeV
- Running at 100 Hz with two beam-delivery systems and two IP

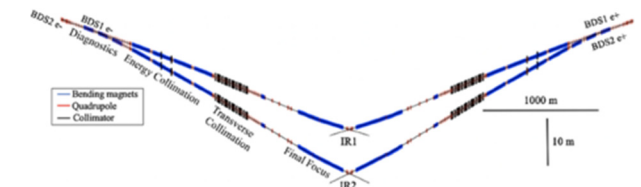
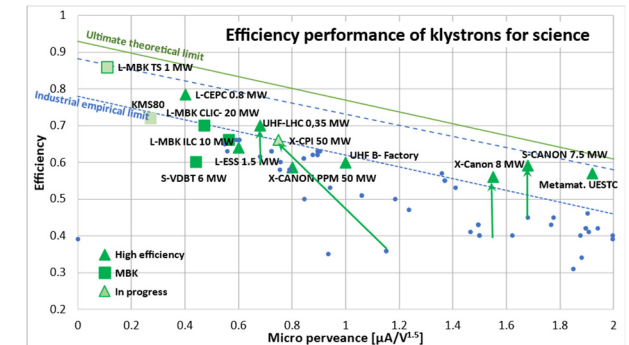
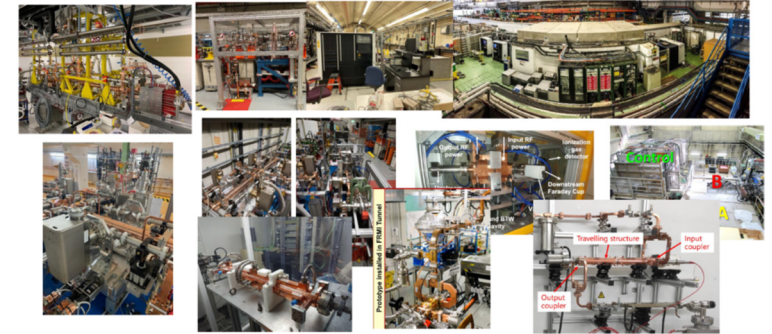
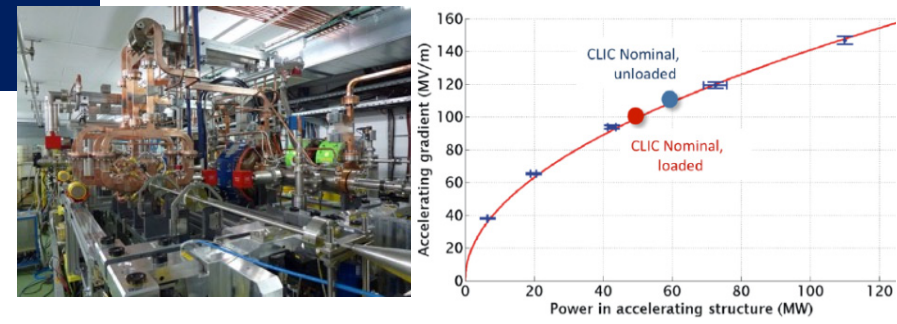

Figure 3: Schematic layout of CLIC operating with two detectors. From [16].

CLIC RF

CLIC baseline - a drive-beam based machine with initial stage of 380 GeV

- RF challenges
 - High-current drive beam bunched at 12 GHz
 - Power transfer and main-beam acceleration, efficient RF power
 - Towards 100 MV/m gradient in main-beam X-band cavities
- The CTF3 (CLIC Test Facility at CERN) addressed all two-beam issues
- X-band technology developed and verified with prototyping, test-stands, and use in smaller systems and linacs
- Two C-band XFELS (SACLA and SwissFEL – the latter particularly relevant) now operational: large-scale demonstrations of normal-conducting, high-frequency, low-emittance linacs. Also ongoing, 1 GeV X-band linac at LNF (EUPRAXIA)
- High efficiency power sources



See much more in ESPP Venice talk by Walter Wuensch: [LINK](#)

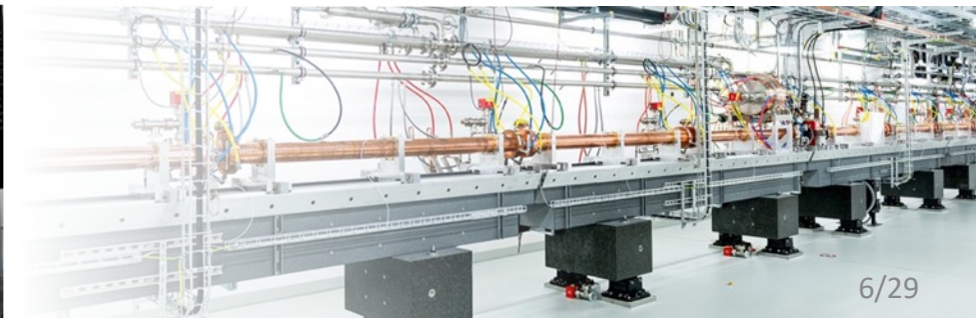
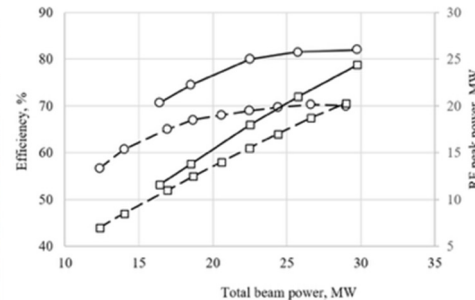

The CLIC ESPP parameters

Key parameters for 380 GeV and 1.5 TeV stages of CLIC. Parameters for energy options at 250 GeV and 550 GeV are also given; for these options the power and luminosity are scaled, based on the 380 GeV and 1.5 TeV designs.

**The luminosity for the 1.5 TeV machine has not been updated to reflect recent alignment studies [15]. If the same method is applied, the luminosity at 1.5 TeV is expected to reach $5.6 \times 10^{34} \text{ cm}^{-2} \text{ s}^{-1}$*

Parameter	Unit	380 GeV	1.5 TeV	250 GeV	550 GeV
Centre-of-mass energy	GeV	380	1500	250	550
Repetition frequency	Hz	100	50	100	100
Nb. of bunches per train		352	312	352	352
Bunch separation	ns	0.5	0.5	0.5	0.5
Pulse length	ns	244	244	244	244
Accelerating gradient	MV/m	72	72/100	72	72
Total luminosity	$10^{34} \text{ cm}^{-2} \text{ s}^{-1}$	4.5	3.7*	~3.0	~6.5
Lum. above 99% of \sqrt{s}	$10^{34} \text{ cm}^{-2} \text{ s}^{-1}$	2.7	1.4	~2.1	~3.2
Total int. lum. per year	fb^{-1}	540	444	~350	~780
Power consumption	MW	166	287	~130	~210
Main linac tunnel length	km	11.4	29.0	11.4	~15
Nb. of particles per bunch	10^9	5.2	3.7	5.2	5.2
Bunch length	μm	70	44	70	70
IP beam size	nm	149/2.0	60/1.5	~184/2.5	~124/1.7

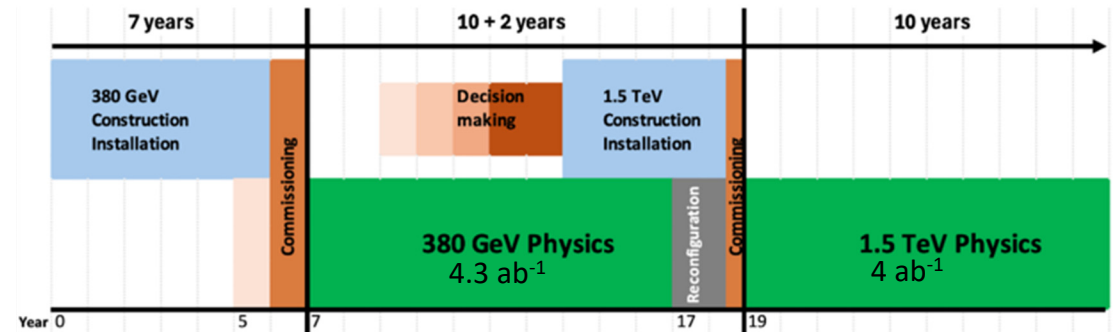

- Z pole performance, $6.3 \times 10^{32} - 1.2 \times 10^{34} \text{ cm}^{-2} \text{ s}^{-1}$
 - The latter number when accelerator configured for Z running (e.g. early or at the end of the first stage)
- An alternative upgrade to 550 GeV, maintaining the repetition rate at 100 Hz and two IPs, is also considered. A possible implementation would be to start with a longer tunnel by 5 km from the beginning adding about 25 % to the initial cost of the CE of the baseline 380 GeV machine.

From the ILC250 accelerator facility to the CERN SCRF LCF

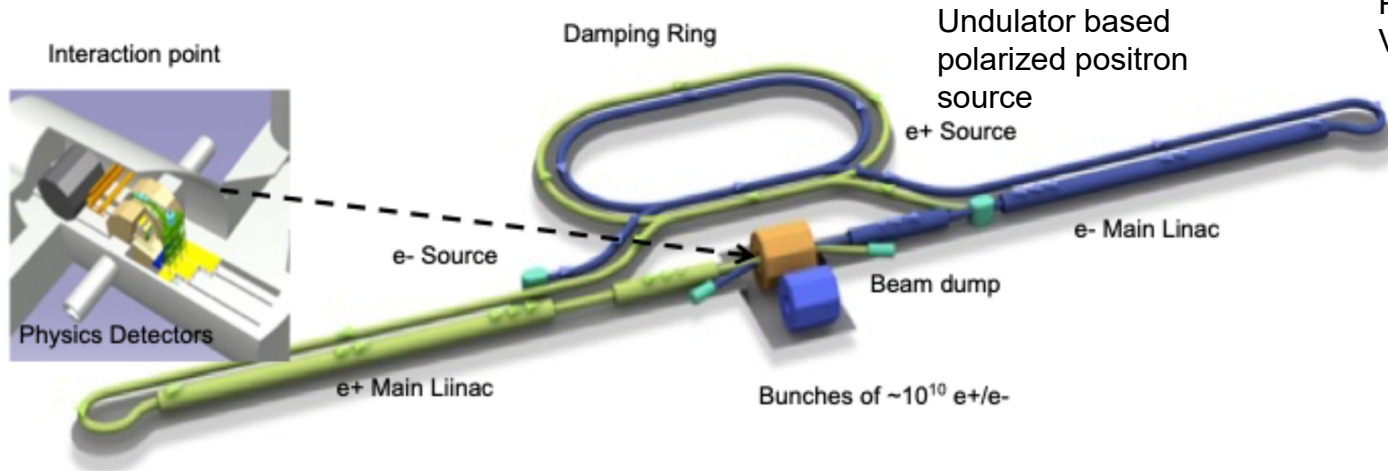

See more details in the presentation of Peter McIntosh in Venice ([LINK](#))



The ILC implementation is extensively studied in Japan, civil engineering, integration locally, environmental impacts, etc

How would we implement a SCRF based LC at CERN:

- Consider implementation of energies above 250 GeV (even initially), similar to the ILC TDR, specifically 550 GeV
- Increase luminosity wrt to parameters used recently (ILC@Japan) and share on two IPs
 - Key changes: Bunch trains 5 Hz to 10 Hz, double numbers of bunches per train
- Set more ambitious goals for energy efficiencies (cavities, klystrons)
- Consider if such a facility can use improved or other RF technologies in the future (a true LC facility) – stimulate wide R&D and open options for the future
- Combine with CLIC footprint/studies as much as possible.
- Cost estimate as for CERN projects in CHF, with CE costs from CERN

LCF – SCRF – ESPP parameters

Quantity Name	Symbol	Unit LCF	Upgrades			Upgrade	
			Initial-250 250 LP	250 FP	550 FP	Initial-550 550 LP	550 FP
Centre-of-mass energy	\sqrt{s}	GeV	250	250	550	550	550
Inst. luminosity	\mathcal{L} ($10^{34} \text{ cm}^{-2} \text{ s}^{-1}$)		2.7	5.4	7.7	3.9	7.7
Polarisation	$ P(e^-) / P(e^+) $ (%)		80 / 30	80 / 30	80 / 60	80 / 30	80 / 60
Repetition frequency	f_{rep}	Hz	10	10	10	10	10
Bunches per pulse	n_{bunch}		1312	2625	2625	1312	2625
Bunch population	N_b	10^{10}	2	2	2	2	2
Linac bunch interval	Δt_b	ns	554	366	366	554	366
Beam current in pulse	I_{pulse}	mA	5.8	8.8	8.8	5.8	8.8
Beam pulse duration	t_{pulse}	μs	727	897	897	727	897
Average beam power	P_{ave}	MW	10.5	21	46	23	46
Norm. hor. emitt. at IP	$\gamma \epsilon_x$	μm	5	5	10	10	10
Norm. vert. emitt. at IP	$\gamma \epsilon_y$	nm	35	35	35	35	35
RMS hor. beam size at IP	σ_x^*	nm	516	516	452	452	452
RMS vert. beam size at IP	σ_y^*	nm	7.7	7.7	5.6	5.6	5.6
Lumi frac. in top 1 %	$\mathcal{L}_{0.01}/\mathcal{L}$	%	73	73	58	58	58
Lumi in top 1 %	$\mathcal{L}_{0.01}$ ($10^{34} \text{ cm}^{-2} \text{ s}^{-1}$)		2.0	4.0	4.5	2.2	4.5
Site AC power	P_{site}	MW	143	182	322	250	322
Annual energy consumption		TWh	0.8	1.0	1.8	1.4	1.8
Site length	L_{site}	km	33.5	33.5	33.5	33.5	33.5
Average gradient	g	MV/m	31.5	31.5	31.5	31.5	31.5
Quality factor	Q_0	10^{10}	2	2	2	2	2
Construction cost		BCHF	8.29	+0.77	+5.46	13.13	+1.40
Construction labour		kFTE y	10.12		+3.65	13.77	
Operation and maintenance		MCHF/y	156	182	322	273	322
Electricity		MCHF/y	66	77	142	115	142
Operating personnel		FTE	640	640	850	850	850

Baseline (10Hz rate)

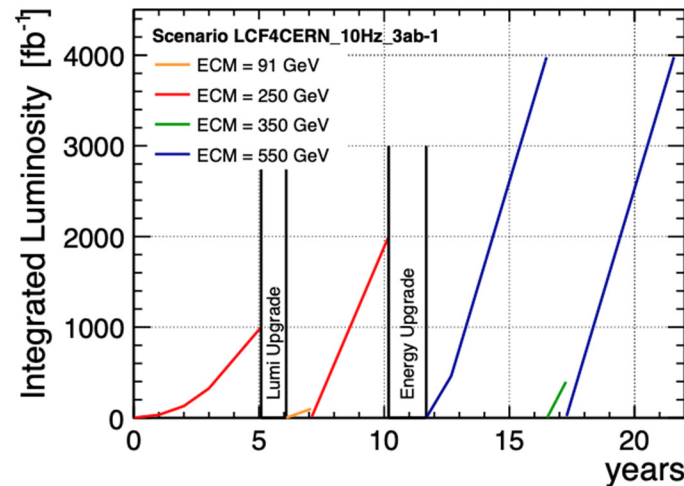

Start immediately with full power (1316->2625 bunches in train)

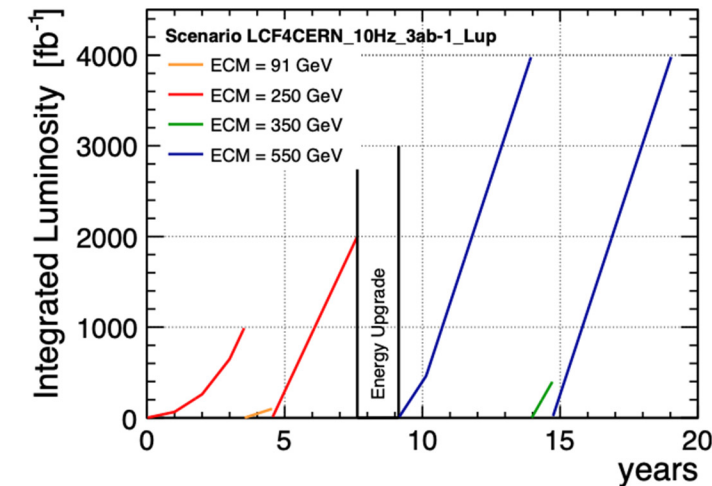

Summary table of the LCF accelerator parameters in the initial 250 GeV configuration and possible upgrades, as well as in an initial 550 GeV configuration and its luminosity upgrade

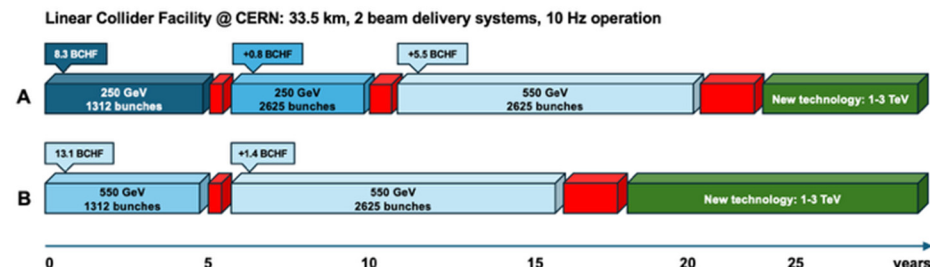

Note: the tunnel length to allow a 550 GeV upgrade is included in the initial programme

LCF with SCRF

SCRF features:

- Very detailed and mature technical design and industrialisation, several FEL linacs build and being operated
- Can be upgraded in Energy and Luminosity
- Worldwide interest in technology

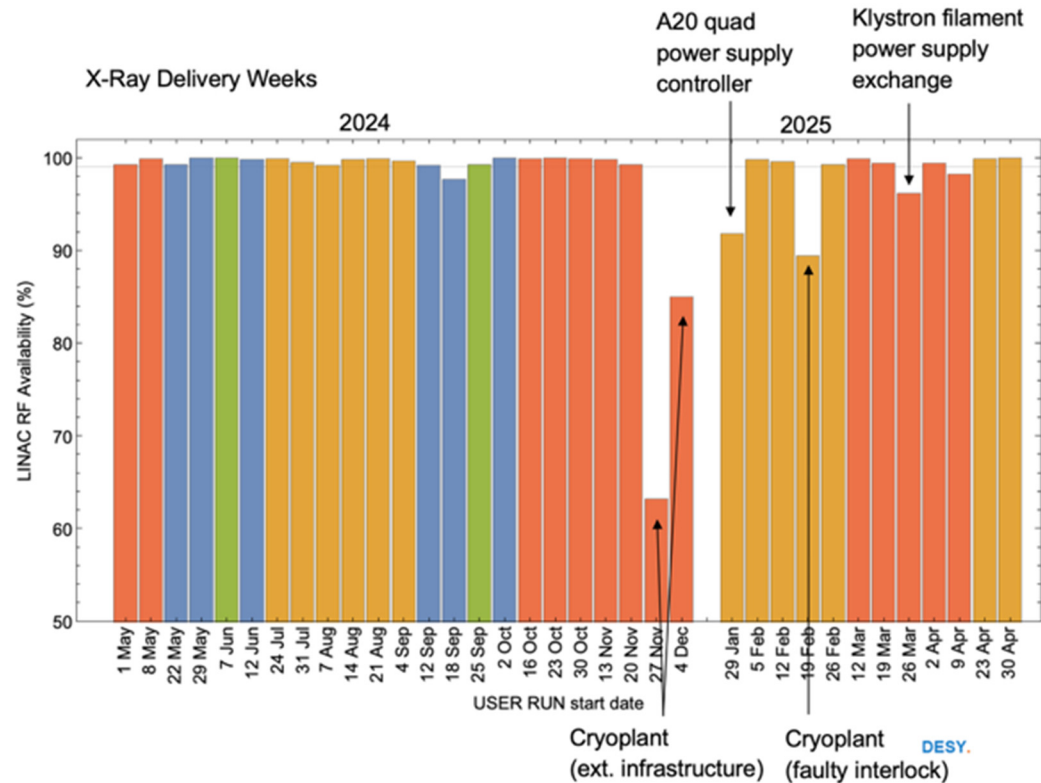

EU-XFEL performance 2024-25

The ILC technology network (ITN)

ITN related studies (dedicated funding from Japan combined resources in participating labs) are distributed over the main technology challenges (see midterm report: [LINK](#)):

ML related tasks

- SRF and ML elements: Cavities and Cryo Module, Crab-cavities, Main Linac quads and cold BPMs

Sources

- Pulsed magnet and wheel/target for undulator scheme
- Conventional source

Damping Ring including kickers

- Low Emittance Rings

ATF3 activities, final focus and nanobeams

- ATF collaboration studies and MDI

And also implementation

- Civil Engineering, Cryogenics, Sustainability, Life Cycle Assessments
- EAJADE (EU funding) for training of young scientists (linear and circular machines)

Studies in many labs: KEK, Korea, Australia, CERN, UK, Germany, France, Italy, Spain, US (limited)

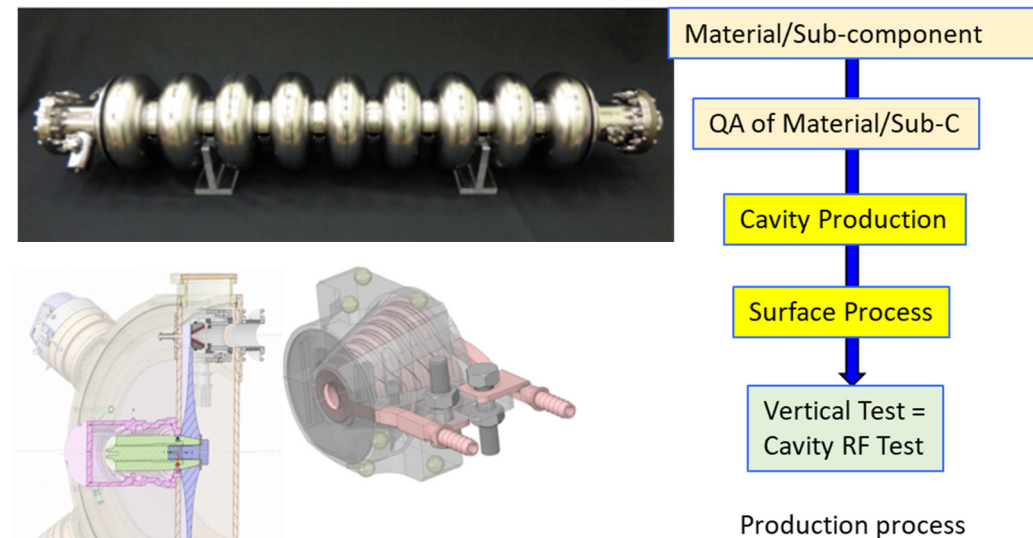

See more details in the Venice presentation of Peter McIntosh ([LINK](#)) and Angeles Faus-Golfe on ATF2-3 ([LINK](#))

Results from FG 9-cell cavity using 2-step baking **KEK and FNAL**

Possible to achieve > 40 MV/m with high Q_0

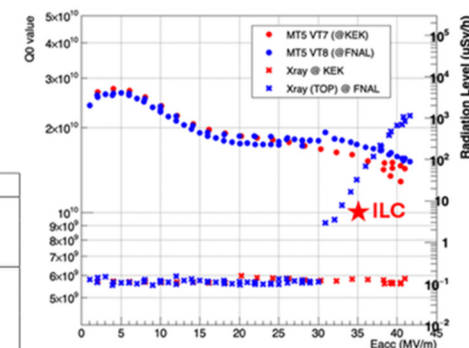

Area	WPP	Name
Superconductivity	1	Cavity production
	2	Cryomodule design
	3	Crab cavity
Sources	4	E-source
	6	Undulator target
	7	Undulator focusing
	8	Electron-driven target
	9	Electron-driven focusing
	10	E-driven capture
	11	Target replacement
	Nano-beam	12
14		Dmping Ring Injection/extraction
15		Final focus
16		Final doublet
17		Main dump

Luminosity related studies – examples

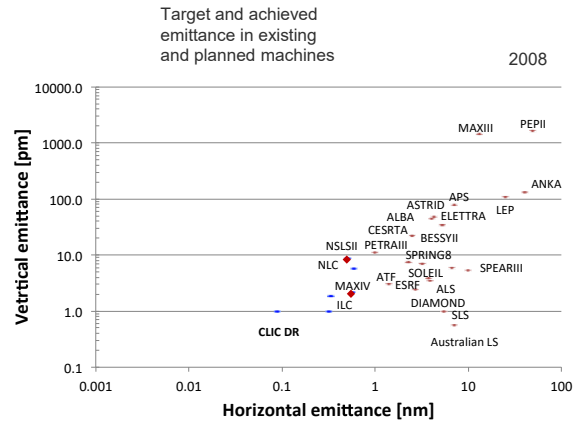

Low emittance damping rings, preservation to the IP, final focus

- Align components (10 μm over 200 m)
- Control/damp vibrations (from ground to accelerator)
- Beam based measurements – allow to steer beam and optimize positions
- Algorithms for measurements, beam and component optimization, feedbacks
- Experimental tests in existing accelerators of equipment and algorithms (FACET at Stanford, ATF2 at KEK, CTF3, Light-sources)
- Final focus optimization, components, instrumentation and test (ATF the central facility)



Longitudinal variable magnet for CLIC damping rings, wiggler prototype in KARA, extraction kicker in ALBA

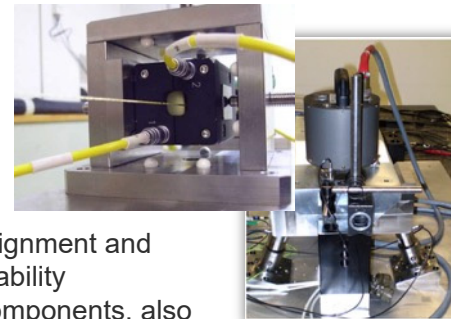
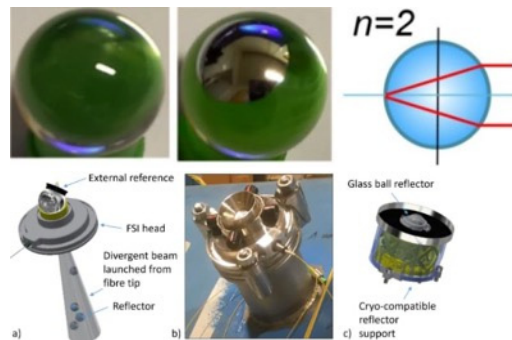
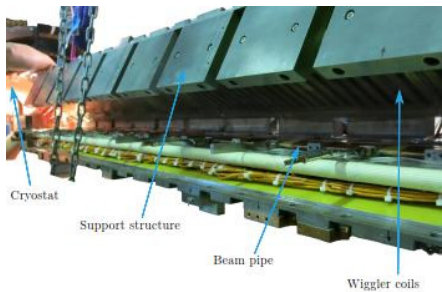

Alignment and stability components, also used in HL LHC

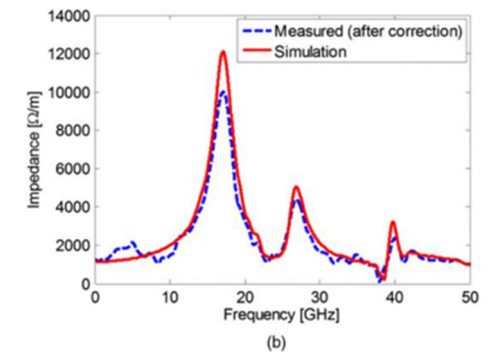
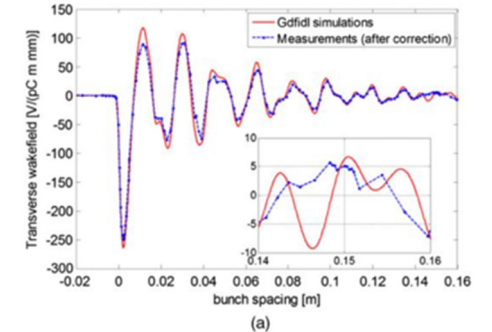

Wake-field measurements in FACET

- (a) Wakefield plots compared with numerical simulations.
- (b) Spectrum of measured data versus numerical simulation.

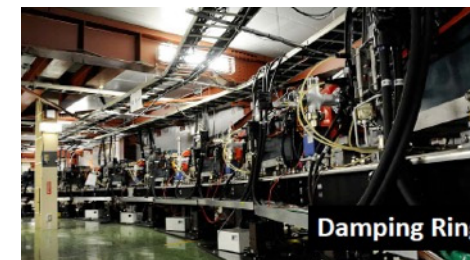
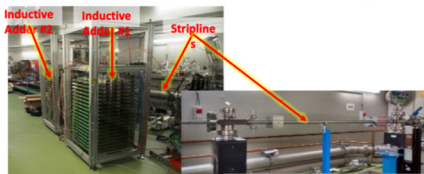

ATF2-3 at KEK: Damping Ring and Final Focus beamline

Luminosity related studies – examples

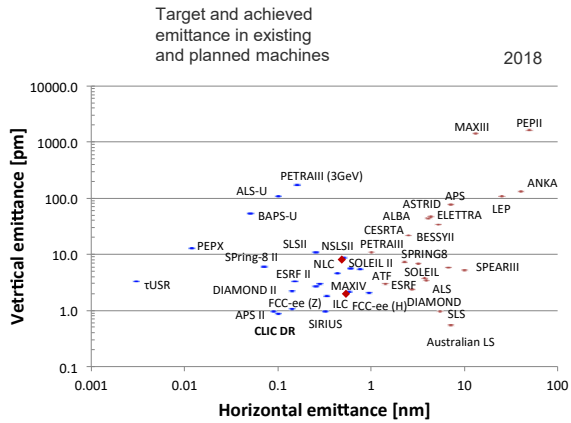

Longitudinal variable magnet for CLIC damping rings, wiggler prototype in KARA, extraction kicker in ALBA

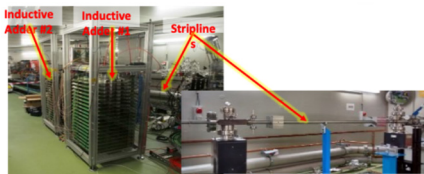
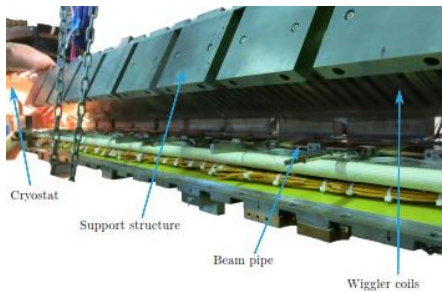

Low emittance damping rings, preservation to the IP, final focus

- Align components (10 μm over 200 m)
- Control/damp vibrations (from ground to accelerator)
- Beam based measurements – allow to steer beam and optimize positions
- Algorithms for measurements, beam and component optimization, feedbacks
- Experimental tests in existing accelerators of equipment and algorithms (FACET at Stanford, ATF2 at KEK, CTF3, Light-sources)
- Final focus optimization, components, instrumentation and test (ATF the central facility)

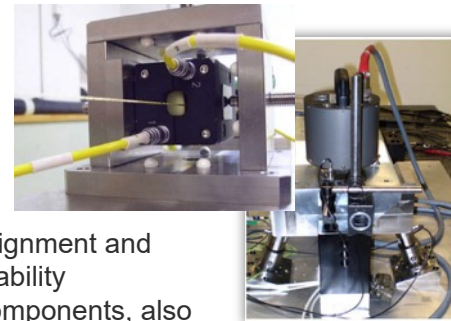
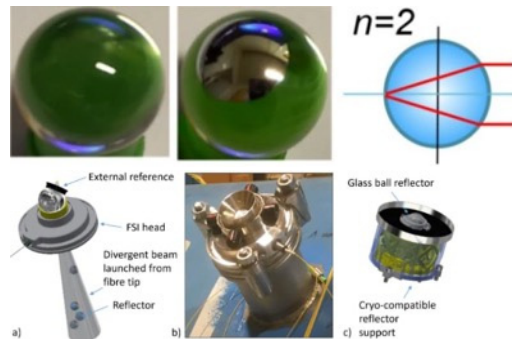

Alignment and stability components, also used in HL LHC

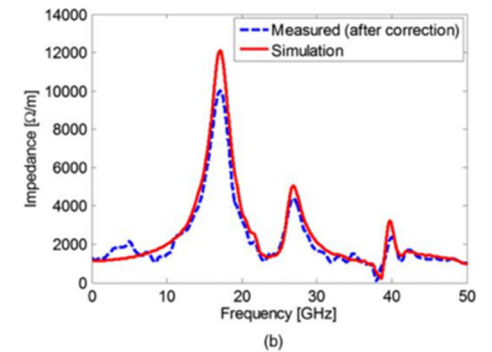
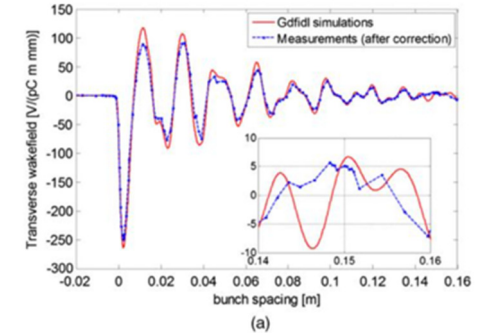

Wake-field measurements in FACET

- (a) Wakefield plots compared with numerical simulations.
- (b) Spectrum of measured data versus numerical simulation.

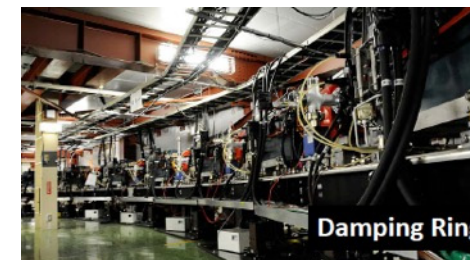

ATF2-3 at KEK: Damping Ring and Final Focus beamline

Linear Collider @ CERN – Civil Engineering

Layout used for costing and drawings. Not final, can be translated, rotated and shafts can be moved.

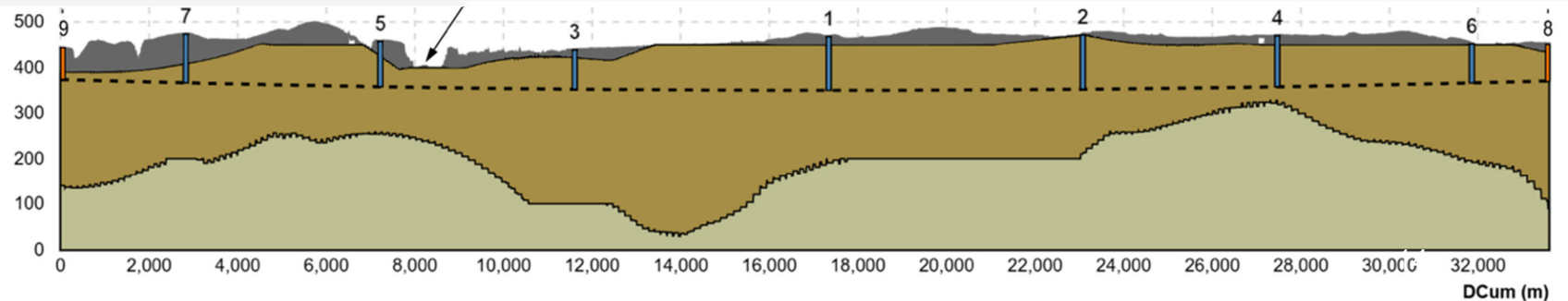
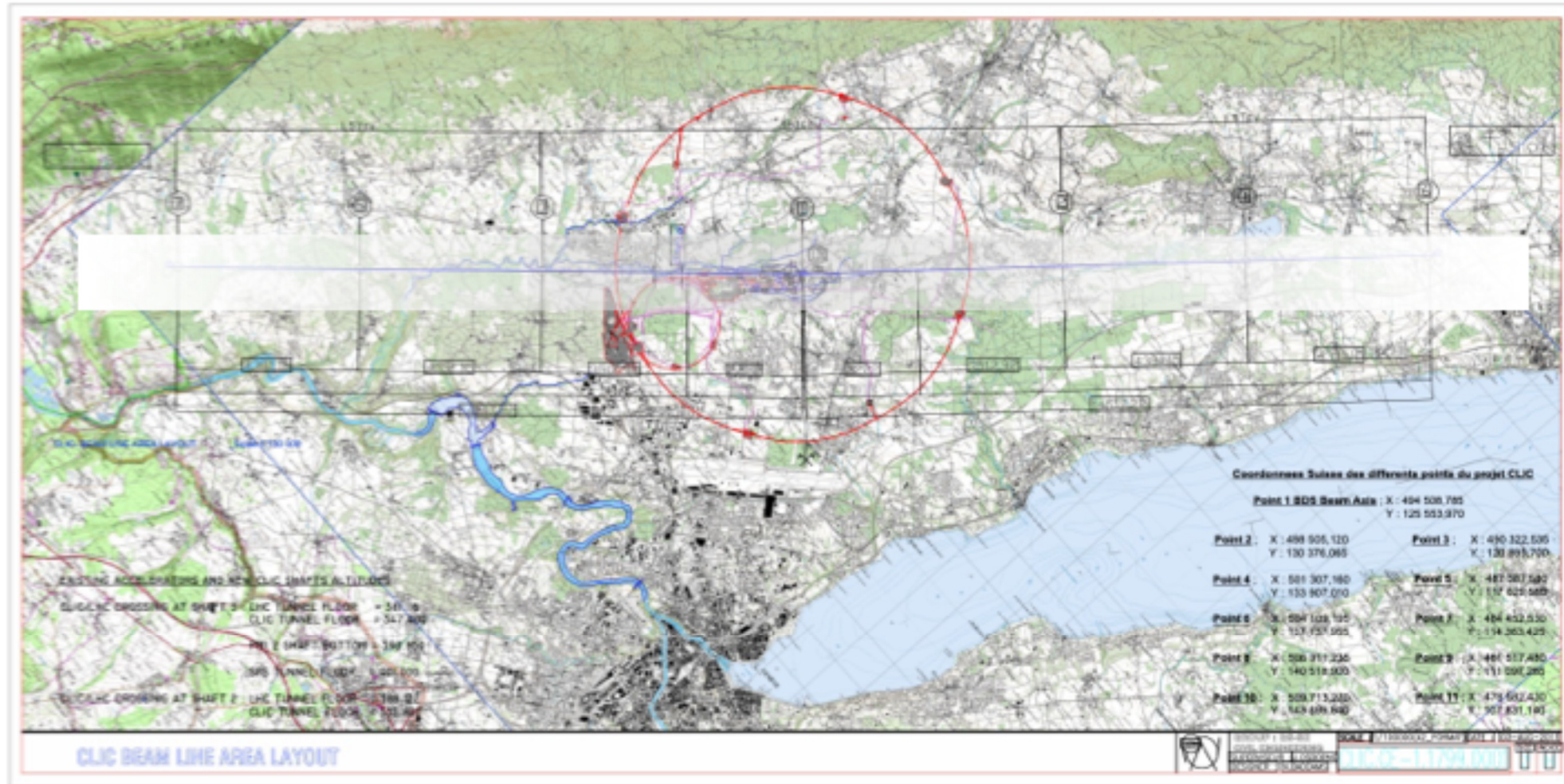
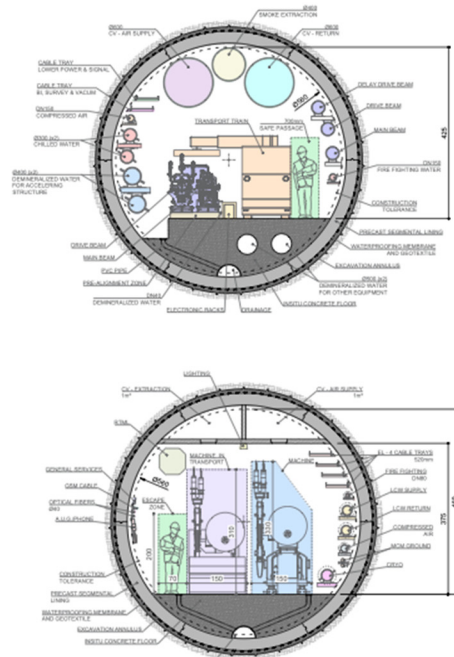

Layout and Placement Study

- CERN placement optimisation tool with several scenarios under evaluation.
- The collider may be rotated to determine the most practical alignment.
- Assessment Criteria:
 - Feasibility of land acquisition based on land classification
 - Accessibility for construction
 - Accessibility for long term operation
 - Suitability of local geology for Shaft & Cavern construction
- Two IP locations possible for LC

Note, to do an improved Civil Engineering study we need to study and baseline:

StoE for lattice/layout, BDS with two IP, dumps, klystron/modulators, cryo, services and infrastructure (CV, EL, access, safety, alignment, installation, etc), injectors including e+, DRs, running and upgrade scenarios, etc.

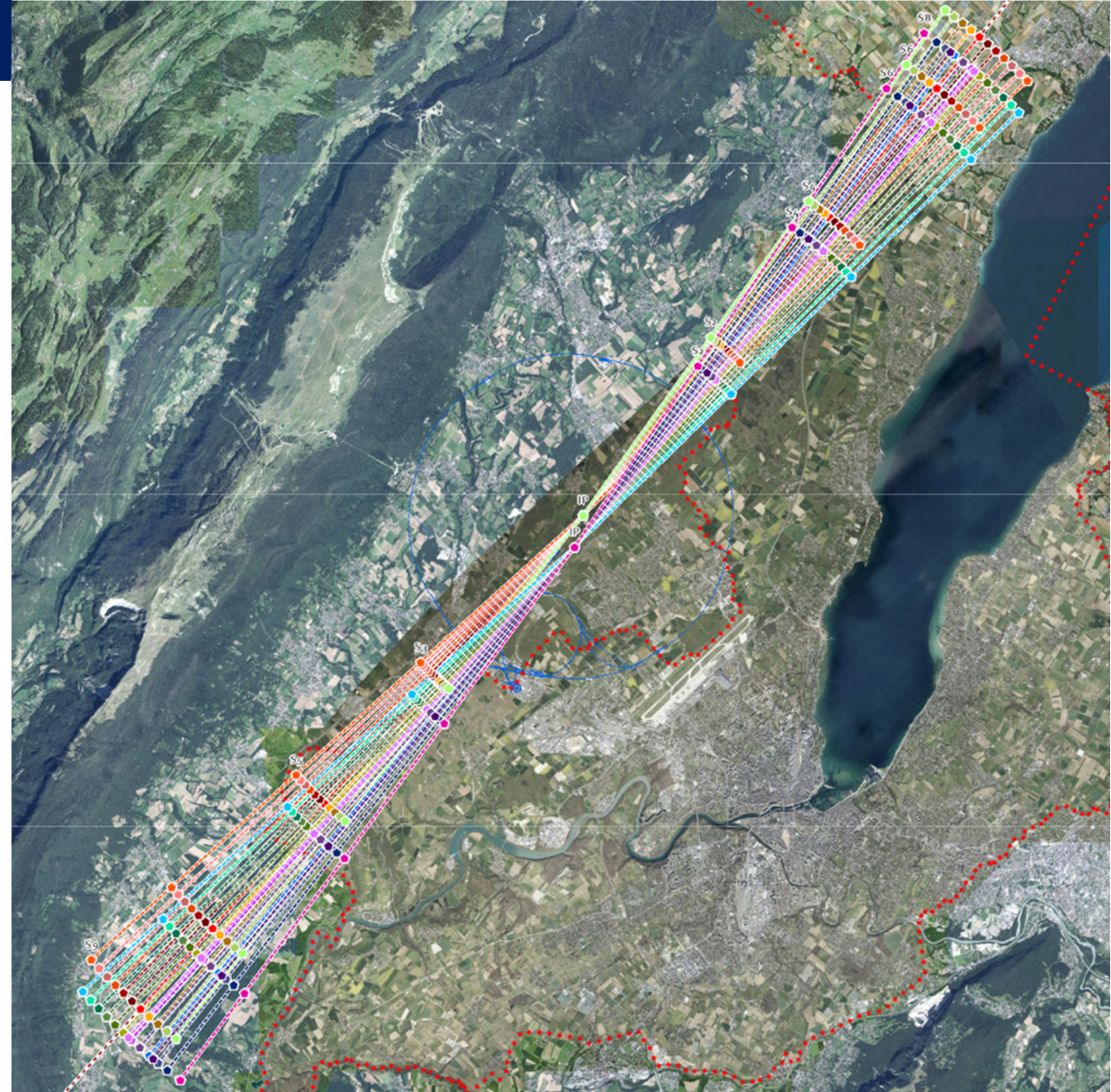

Linear Collider @ CERN – Civil Engineering

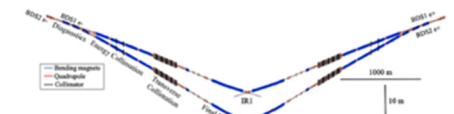
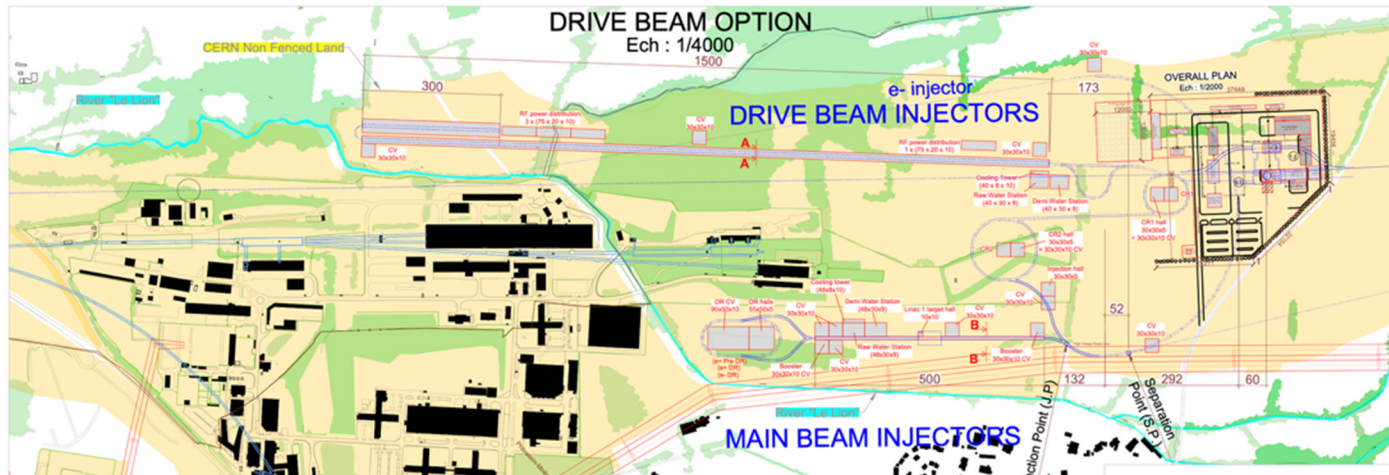
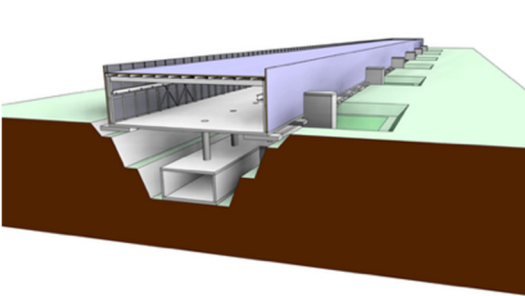
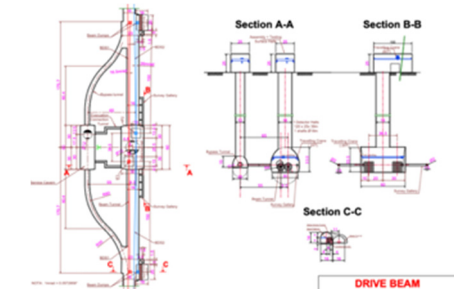

Figure 3: Schematic layout of CLIC operating with two detectors. From [16].



CE studies for LC at CERN over the last ~15 years:

- CLIC, up to 3 TeV. Contract with Amberg Engineering for CDR in 2012-2013.
- ILC up to 1 TeV. Contract with Amberg Engineering for the TDR in 2012-13.
- CLIC up to 3 TeV, TOT (layout tool) with ARUP (engineering/consulting company), for the Project Implementation Report 2018
- For the ESPP 2025, LCF/ILC up to 550 GeV, CLIC NCRF to 1.5 TeV, in both cases ~30km (29.5 and 33.5), using Geoprofiler layout tool
- Injectors and experimental areas on Preveessin site (“CERN attributed land”)

Costs – for construction

Unit: MCHF	LCF 250 (LP)	Δ LCF 550 (FP)	CLIC 380	Δ CLIC 1500	Cost Class
Collider	3864	4204	2471	4684	3/3-4
Main Beam inj./transfer	1181	86	1046	23	3/3-4
Drivebeam inj./transfer	-	-	1060	302	3/3-4
Civil Engineering	2338	0	1403	703	4
Technical Infrastructure	1109	1174	1361	1404	4
Sum	8292	5464	7241	7116	

From “comparative report” ([LINK](#)):

- Low Power (1312 bunches per train),
- Full Power (2625 bunches per train)
- CLIC 550 GeV is 30% higher than CLIC 380
- In the report two experiments (not in table on the right) are estimated to 795 MCHF
- Spoil removal of 100/200M (LCF/CLIC) to be added beyond the collider CE

ILC/LCF Cost exercises – and international reviews:

- ILC TDR 2012-13, 500 GeV primarily ([LINK](#))
- ILC in Japan 2017-18, 250 GeV, reviewed by LCC ([LINK](#))
- Updates and review recently done for ILC Japan 19-20.12.2024 ([LINK](#))

CLIC cost exercises – and international reviews:

- CLIC CDR 2012-13, 3 TeV primarily and 500 GeV ([LINK](#))
- CLIC PiP 2018, 380 GeV primarily ([LINK](#))
- Updated 2024-25

For “ILC like” implementation at CERN:

- Redid Civil Engineering (CE) costing (previous slide); CE costs based on CLIC and other CERN projects, based on ILC layout with same linac footprint as for CLIC
- Redid CF costing (EL, CV, etc)
- Use 2024 costing for all components in their respective currencies, and change to CHF with exchange rate

Power and energy

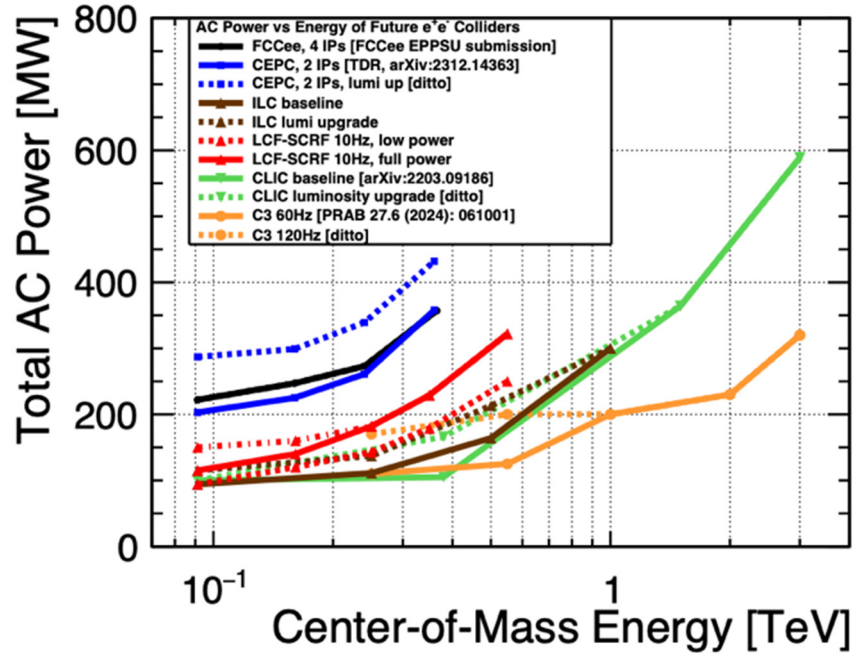

Power at 250-550 GeV in the 140-320 MW range for the LC projects above

Depends on energy AND luminosity (as shown earlier)

With a running scenario on the right this corresponds to 0.8 - 1.8 TWh annually

CERN is currently consuming 1.2 – 1.3 TWh annually

CERN “standard” running scenario used to convert to annual energy use, specify power for each state → energy

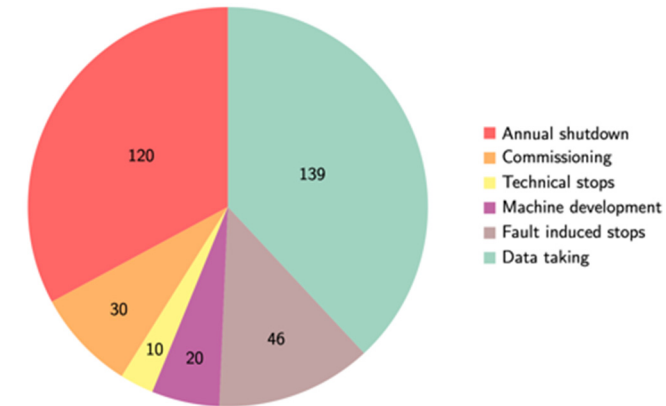

A decade of studies to reduce power:

Designs optimisations, SRF cavities (grad,Q), cryo efficiency, RF power system (klystrons, modulators, components), RF to beam efficiencies, improved magnets, operation when power is abundant, heat recovery, nanobeams and more.

	LCF 250 (LP)	LCF 550 (FP)	CLIC 380	CLIC 1500
Power (MW)	144	320	166	287
Energy annually (TWh)	0.8	1.8	0.8	1.4

ESPP LC documentation – input

CLIC@CERN, Linear Collider Facility starting with NCRF technology:
<https://indico.cern.ch/event/1439855/contributions/6461475/>



CLIC Readiness Report in EPJ:
<https://link.springer.com/article/10.1140/epjs/s11734-025-02016-w>

LCF@CERN, Linear Collider Facility starting with SCRF technology:
<https://indico.cern.ch/event/1439855/contributions/6461433/>
<https://indico.cern.ch/event/1439855/contributions/6461548/>



Long linear collider vision document:
<https://arxiv.org/abs/2503.19983>



The screenshot shows the arXiv preprint page for the document "Future Colliders Comparative Evaluation - Working Group Report". The page includes the title, authors (G. Arduini, M. Benedikt, F. Gianotti, K. Jakobs, M. Lamont, R. Losito, M. Meddahi, J. Mnich, N. Mounet, D. Schulte, F. Sonnemann, S. Staples, F. Zimmermann), a submission date of 25 Nov 2025, and a detailed abstract. The abstract discusses the completion of the High-Luminosity Large Hadron Collider (HL-LHC) programme and the preparation for a new major facility in the mid-2040s. It mentions the European Strategy for Particle Physics (ESPP) and the Future Colliders Comparative Evaluation working group. The page also features a "Comments" section, a "Subjects" list (Accelerator Physics, High Energy Physics - Experiment), and a "Submission history" section.

Comparative report:
<https://arxiv.org/pdf/2511.20417>

ESPP review documents and results



Physics Preparatory Group:

<https://cds.cern.ch/record/2944678>

Report from the ESG WG2a (Comparative Analysis): Specific written input provided, included follow up meetings with the committee, for both LCF/SCRF and CLIC in September/early October.

- Topics: Scope, Schedule, Costs, Risks and risk management, TRLs and R&D, Civil Engineering, some specific questions

Report: https://cds.cern.ch/record/2947728/files/ESG_WG2a_Final.pdf



Deliberation Document: [LINK](#)

Recommendation Document: [LINK](#)

The evaluation of LCF in each criteria in the form of a traffic light table is given in Table 9. A comparison across projects is given in the Appendix in Tables A.1 to A.8.

Project	Scope	TRL	R&D	Test facilities	Performance	Site preparation	Schedule	Cost	Risk
LCF 250-550GeV	Green	5 - 7 / 5.5	Green	Green	Green	Yellow	Yellow	Yellow	Yellow

Table 9: Traffic light summary table for LCF.

comparison across projects is given in the Appendix in Tables A.1 to A.8.

Project	Scope	TRL	R&D	Test facilities	Performance	Site preparation	Schedule	Cost	Risk
CLIC 380GeV 1.5TeV	Green	4 - 6 / 5.2	Yellow	Yellow	Yellow	Yellow	Yellow	Yellow	Yellow

Table 3: Traffic light summary table for CLIC.

Linear Colliders: from “construction-ready” to R&D

- International Linear Collider (ILC)
 - superconducting RF 31-35 MV/m
 - proven technology: Eu.XFEL, LCLS-II, SHINE, ...
 - up to 1 TeV, both beams polarised
 - since 2012 considered for construction in Japan
- Compact Linear Collider (CLIC):
 - beam-driven warm copper RF, 70-100 MV/m
 - up to 3 TeV, electrons polarised
- **A vast number of other ideas / R&D programs***
 - Improved SCRF and NCRF
 - C3: cool copper collider up 150 MV/m
 - HELEN: advanced SCRF up to 70 MV/m
 - ReLiC / ERLC: energy & particle recovery
 - HALHF: hybrid asymmetric linear Higgs factory
 - ALEGRO: 10 TeV PWA $ee / \gamma\gamma$
 - XCC: XFEL-driven $\gamma\gamma$ collider
 - ...

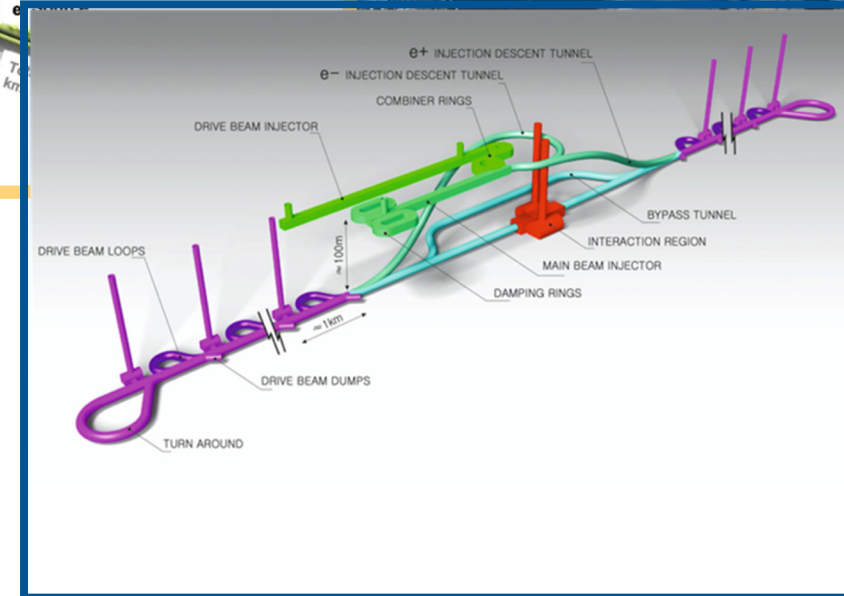
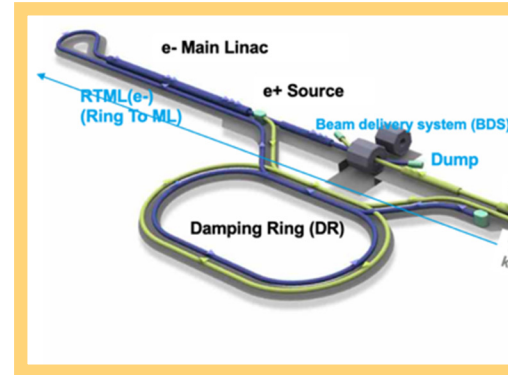

*the following slides are compiled from the talk of J.List at ESPP Venice ([link](#)) and the studies documented in [link](#); and the original slides are in the backup section at the end

Linear Colliders: from “construction-ready” to R&D

- International Linear Collider (ILC)
 - superconducting RF 31-35 MV/m
 - proven technology: Eu.XFEL, LCLS-II, SHINE, ...
 - up to 1 TeV, both beams polarised
 - since 2012 considered for construction in Japan
- Compact Linear Collider (CLIC):
 - beam-driven warm copper RF, 70-100 MV/m
 - up to 3 TeV, electrons polarised
- A vast number of other ideas / R&D programs*
 - Improved SCRF and NCRF
 - C3: cool copper collider up 150 MV/m
 - HELEN: advanced SCRF up to 70 MV/m
 - ReLiC / ERLC: energy & particle recovery
 - HALHF: hybrid asymmetric linear Higgs factory
 - ALEGRO: 10 TeV PWA $ee / \gamma\gamma$
 - XCC: XFEL-driven $\gamma\gamma$ collider
 - ...

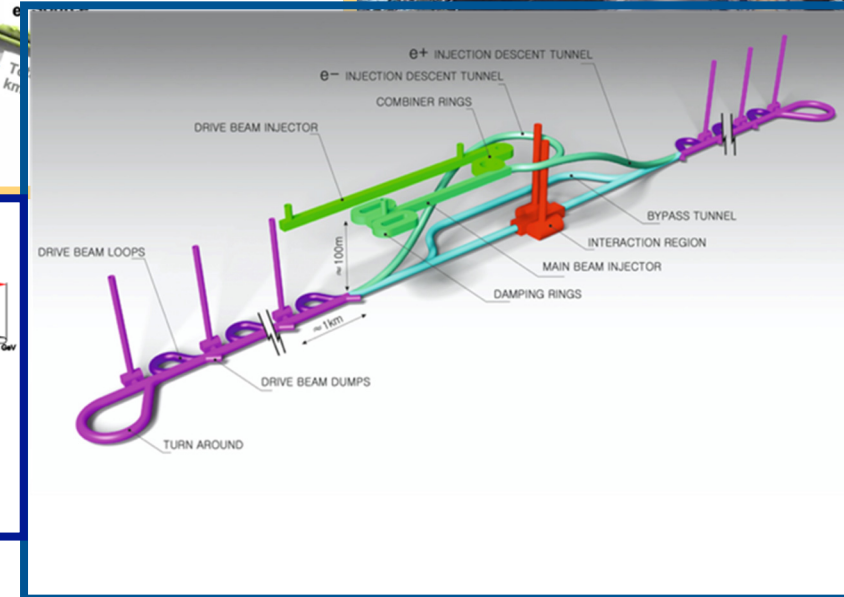
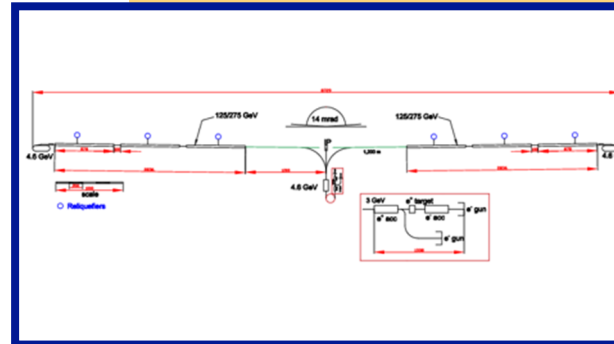
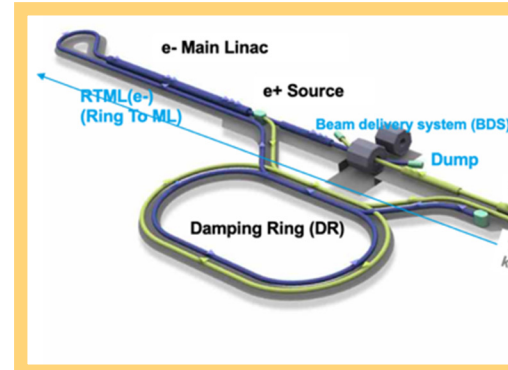

*the following slides are compiled from the talk of J.List at ESPP Venice ([link](#)) and the studies documented in [link](#); and the original slides are in the backup section at the end

Linear Colliders: from “construction-ready” to R&D

- **International Linear Collider (ILC)**
 - superconducting RF 31-35 MV/m
 - proven technology: Eu.XFEL, LCLS-II, SHINE, ...
 - up to 1 TeV, both beams polarised
 - since 2012 considered for construction in Japan
- **Compact Linear Collider (CLIC):**
 - beam-driven warm copper RF, 70-100 MV/m
 - up to 3 TeV, electrons polarised
- **A vast number of other ideas / R&D programs***
 - Improved SCRF and NCRF
 - C3: cool copper collider up 150 MV/m
 - HELEN: advanced SCRF up to 70 MV/m
 - ReLiC / ERLC: energy & particle recovery
 - HALHF: hybrid asymmetric linear Higgs factory
 - ALEGRO: 10 TeV PWA $ee / \gamma\gamma$
 - XCC: XFEL-driven $\gamma\gamma$ collider
 - ...

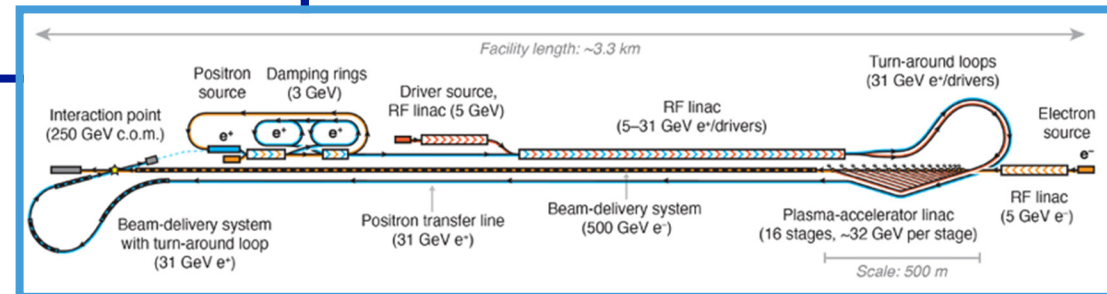
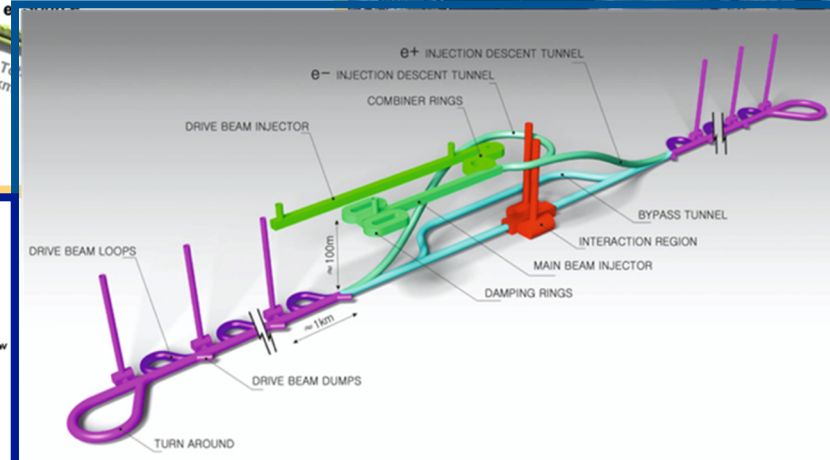
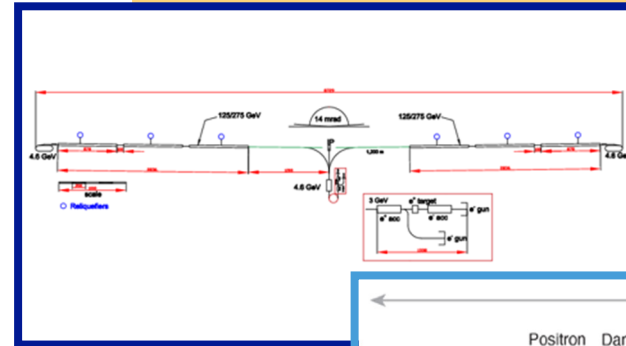
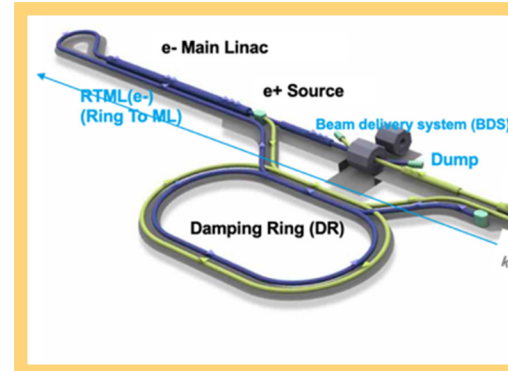

*the following slides are compiled from the talk of J.List at ESPP Venice ([link](#)) and the studies documented in [link](#); and the original slides are in the backup section at the end

Beam-dump / fixed-target / R&D / irradiation

Ample opportunities to include beam extraction / dump instrumentation / far detectors

- extraction of bunches before IP -> mono-energetic, extremely stable, few 10^{10} @ 1-10 Hz => super-LUXE (SF-QED $\chi = O(\text{few hundred})$ & BSM search), super-LDMX, ...
- disrupted beam after IP -> broad energy and highly divergent, but up to 10^{15} eot / s super-SHIP, generic dark photon and ALP searches => together with e+e- cover all Dark Sector portals

Low-emittance, mono-energetic beams ideal for

- high-rate detector and beam instrumentation tests
- creating low-emittance beams of photons / muons / neutrons for various applications (hadron spectroscopy, material science, irradiation, tomography, radioactive isotope production, ...)
- accelerator development:
 - high-gradient accelerating structures, new final focus schemes, deceleration (for ERLs), beam and laser driven plasma, ...
 - from extracted beam to test small setups - to large-scale demonstrators for upgrades of the main facility

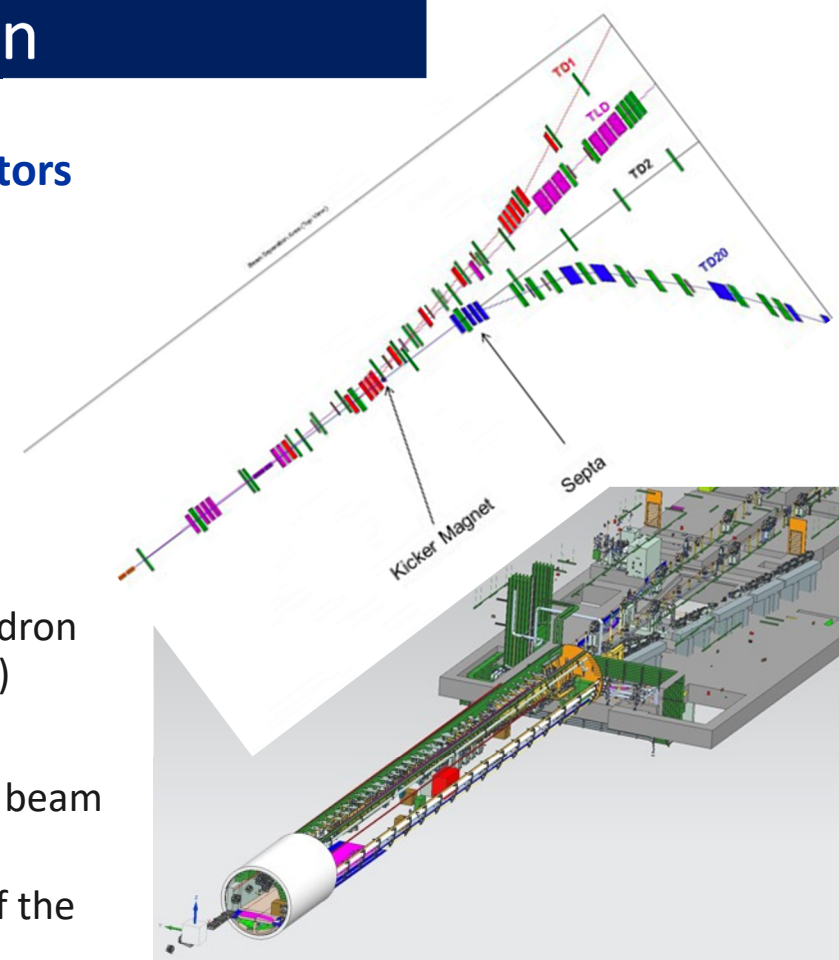

main dump
particle
spectra

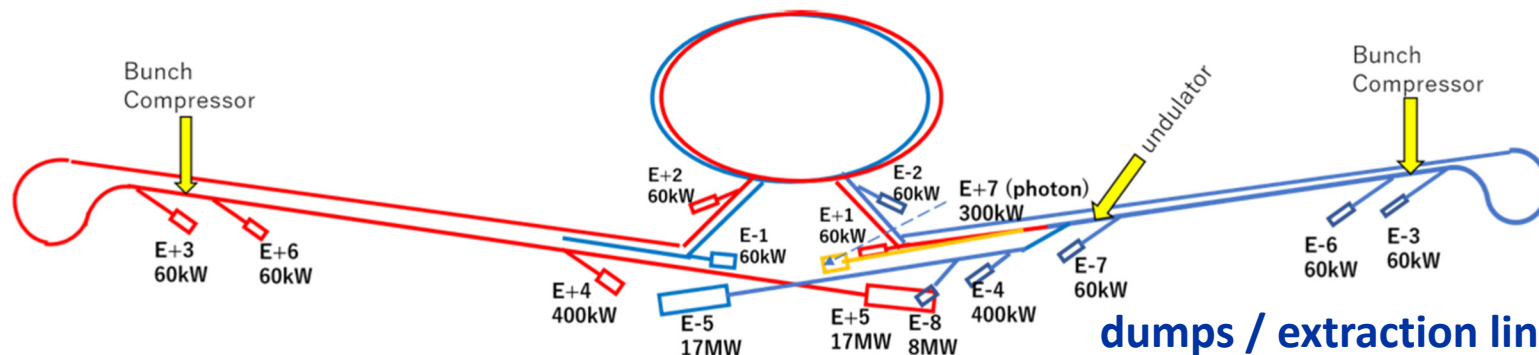

dumps / extraction lines at ILC

Super-conducting RF Upgrades

Need ~60 MV/m to reach 1 TeV in LCF tunnel

- SCRF is one of the key directions of Accelerator R&D Roadmap
 - significant synergies with ERL needs
 - needs to be accompanied by R&D on high-efficiency klystrons, couplers, He refrigerators...
 - progress is funding limited
- **5-year horizon: standing-wave, bulk niobium cavities: 50-60 MV/m**
 - new baking: 2-step (75°/120°) or mid-T followed by low-T
 - new shapes
- **10-year horizon: traveling-wave cavities 60-70 MV/m “HELEN”**
 - substantially lower $k_M \Rightarrow$ higher gradients for same magnetic quench limit
 - 2x higher R/Q \Rightarrow lower losses
 - higher stability of field distribution \rightarrow longer structures
- **>10-year or break-through: Nb₃Sn or multilayer cavities 100 MV/m**
 - ~2x higher transition T than Nb: 2K \rightarrow 4K
 - ~2x higher DC superheating field than Nb
 - to-date only reached gradients up to 24MV/m with Nb₃Sn

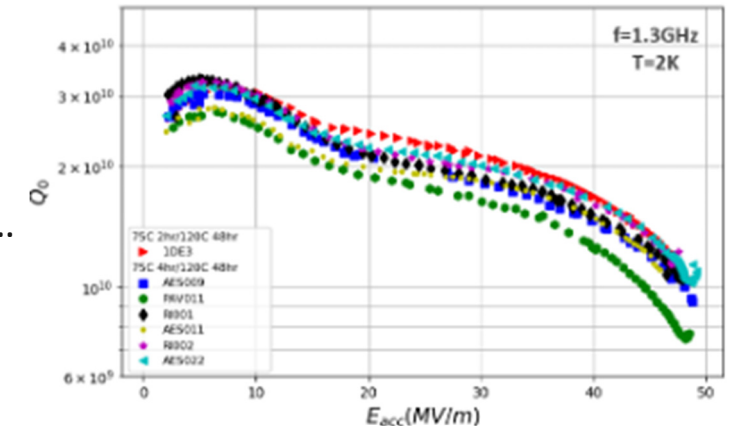

ILC (TESLA) 9-cell standing wave cavity

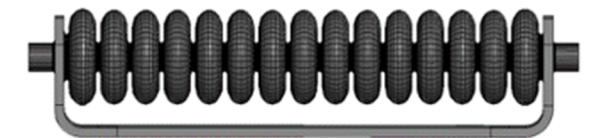

Traveling wave 15-cell SRF cavity

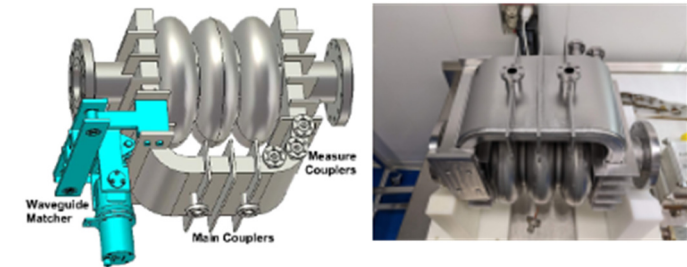

Proof-of-principle 3-cell cavity

Cool Copper Collider and Technology

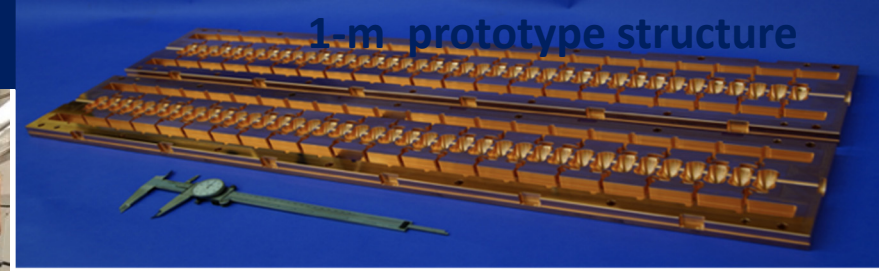

Idea and R&D

• C3 technology:

- normal-conducting C-band copper cavities
- operated at cryogenic temperatures (LN₂ ~80K)
- gradients demonstrated up to 155 MV/m

• R&D:

- plan towards demonstrator established during Snowmass
- since then significant progress on system design, accelerator structure design, high gradient testing, vibration measurements, damping materials, alignment system, low-level rf & klystrons, ... and cryo-module design

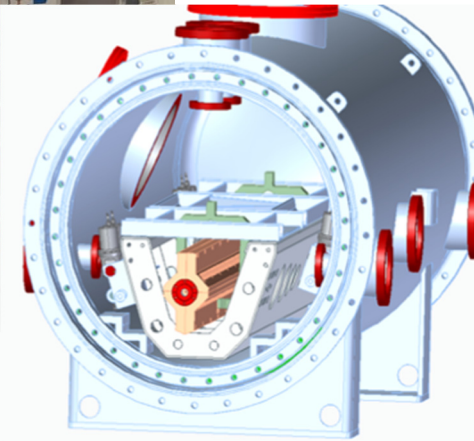
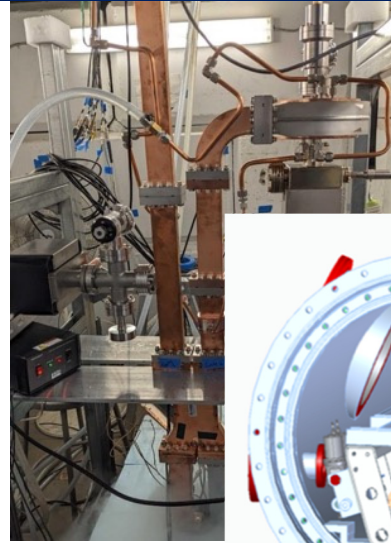

• Stand-alone facility 8km: 250 /550 GeV (70 /120 MV/m)

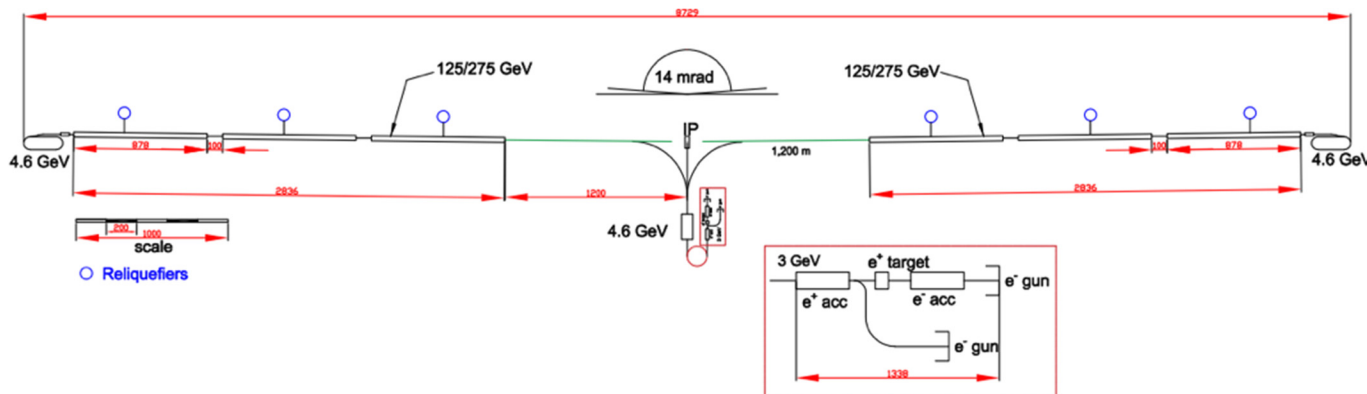

Parameter	Unit	Value	Value	Value
Centre-of-Mass Energy	GeV	1000	2000	3000
Site Length	km	20	20	33
Main Linac Length (per side)	km	7.5	7	10.5
Accel. Grad.	MeV/m	75	155	155
Flat-Top Pulse Length	ns	500	195	195
Cryogenic Load at 77 K	MW	14	20	30
Est. AC Power for RF Sources	MW	68	65	100
Est. Electrical Power for Cryogenic Cooling	MW	81	116	175
Est. Site Power	MW	200	230	320
RF Pulse Compression		N/A	3X	3X
RF Source efficiency (AC line to linac)	%	50	80	80
Luminosity	$\times 10^{34} \text{ cm}^{-2} \text{ s}^{-1}$	~4.5	~9	~14
Single Beam Power	MW	5	9	14
Injection Energy Main Linac	GeV	10	10	10
Train Rep. Rate	Hz	60	60	60
Bunch Charge	nC	1	1	1
Bunch Spacing	ns	3	1.2	1.2

PWA - Hybrid-Asymmetric Linear Higgs Factory, and towards 10 TeV

An e+e- LC using e-beam-driven plasma wakefield acceleration for the e- beam and RF cavities for the e+ beam:

- => asymmetric collisions with $\gamma=1.67$ (HERA: $\gamma=3$), luminosity \sim ILC baseline
- site-length and cost - small & "cheap"
- 250 GeV: 4.9 km, 3.8 BCHF
- 550 GeV: 8.4 km, 6.3 BCHF

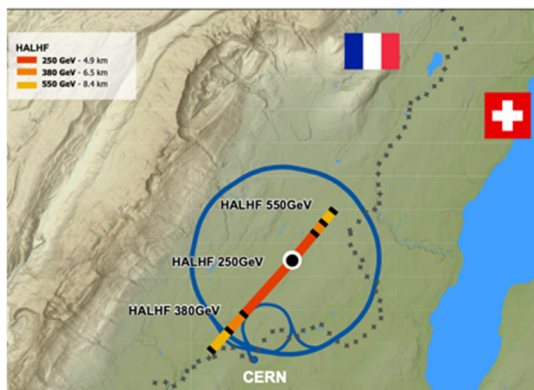

Study how to apply the HALHF-scheme to (asymmetrically) double the ECM of a symmetric e+e- LC:

- example: 250 GeV (125 GeV on 125 GeV) -> 550 GeV (550 GeV on 137.5 GeV, $\gamma=1.2$)
- e-: re-purpose main linac to produce drive-beams for plasma stages => low gradient - high current operation

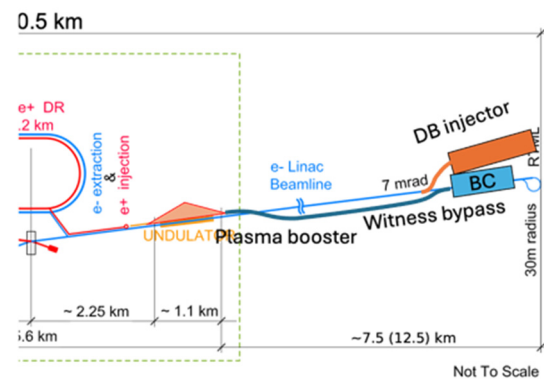

10 TeV Wakefield Collider Study:

- By 2028 produce a unified, self-consistent concept, including cost scales for a 10-TeV parton-center-of-mass (pCM) collider based on wakefield accelerator (WFA) technology
- HEP-wide community effort, involving theorists, experimentalists and Linear Collider experts (~100 participants at last collaboration meeting)

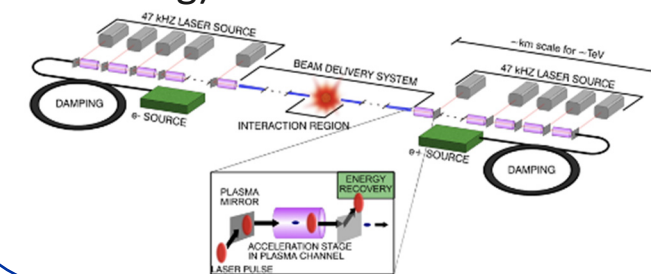

HALHF

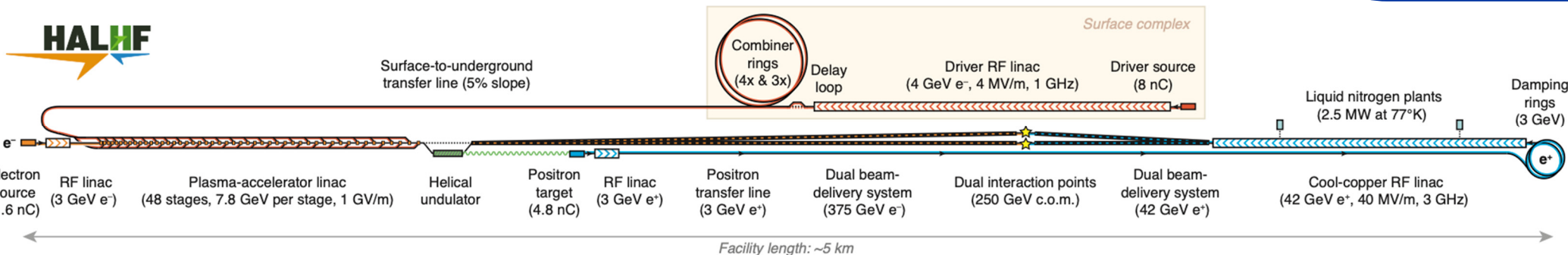

Energy- & Particle Recovery as path to High Luminosities / Photon Collider

- Energy and particle recovery:
 - boost luminosity up to $10^{36} / \text{cm}^2 / \text{s}$ and high e^+ polarisation
 - by re-using particles and energy => requires to limit beamstrahlung, far from disruption limit
 - several concepts - e.g. ReLiC, ERLC, ghost-collider ...
 - most measurements statistics limited => gain everywhere

	LCF	ReLiC ¹	ReLiC ²	ReLiC ³	ReLiC ³
Centre-of-mass energy [GeV]	250	250	250	250	550
Accel. Grad. [MeV/m]	31.5	12.55	12.55	12.55	27.6
Cavity Q ₀ [10 ¹⁰]	2	4	4	4	4
Liquid He temperature [K]	2	2	2	4.5	4.5
Bunch population [10 ¹⁰]	2	2.5	2.5	2.5	2.5
Collision frequency [MHz]	2.62	1.5	1.5	1.5	1.5
Duty cycle	0.0012	cw	cw	cw	cw
Beam current, all beams [mA]	0.042	12	12	12	12
Normalised emittance hor. [μm] / vert. [nm]	5/25	4/1	4/1	4/1	4/1
β _x / β _y [m] / [mm]	0.013/0.41	2.2/0.19	2.2/0.19	2.2/0.19	4/0.36
σ _x / σ _y at IP [μm] / [nm]	0.52/7.7	6/0.9	6/0.9	6/0.9	6/0.9
D _x / D _y	0.5/34.5	0.0187	0.0187	0.0187	0.0188
T _{max}	0.068	0.0028	0.0028	0.0028	0.0031
Luminosity [10 ³⁴ cm ⁻² s ⁻¹]	2.7	140	140	140	153
AC Site Power [MW]	111	~135	~105	~95	~250

¹ ReLiC based on current "conventional" Nb SW SCRF technology [512]. Cryogenics system: 80 MW, damping rings: 70 MW + others
² ReLiC based on Nb SW SCRF technology, but COP of 2 K LiHe refrigerators improved 2-fold. Cryogenics system: 45 MW, damping rings: 70 MW + others
³ ReLiC based on futuristic SCRF technology for Nb3Sn SW cavity with Q₀ = 4E10. 250 GeV: Cryogenics system: 35 MW, damping rings: 70 MW; 500 GeV: Cryogenics system: 95 MW, damping rings: 140 MW

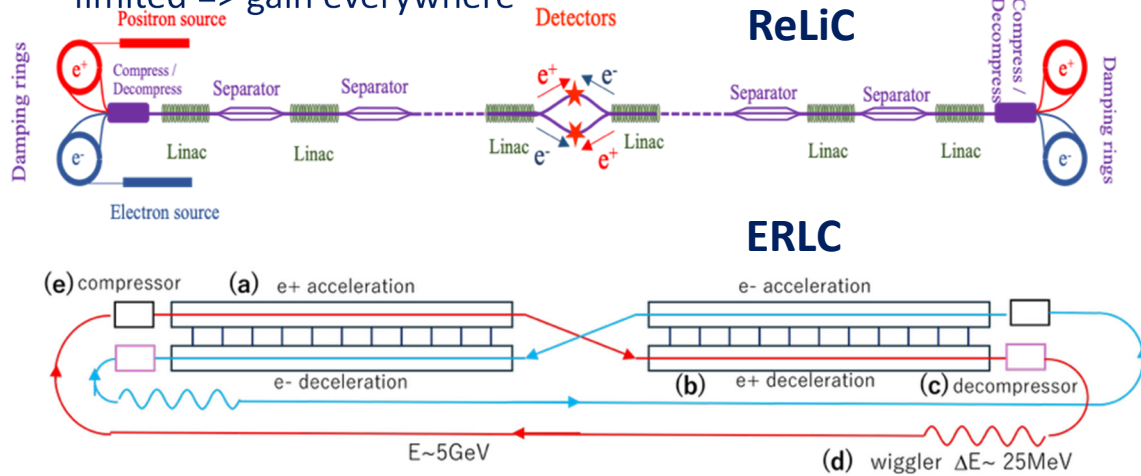

And see talk in the moment by R.Apsimon, MOO1T02
 "The Ghost Collider: An innovative Higgs Factory"

- $\gamma\gamma / e\gamma$ offers unique complementary physics opportunities e.g. self-coupling in $\gamma\gamma \rightarrow \text{HH}$ with different BSM behaviour than e^+e^- / pp
- High-intensity lasers convert e beam(s) into γ beam(s) directly at the IP => spin-0 luminosity spectrum sharply peaked
- Two methods:
 - optical lasers "classic" scheme
 - Recent: X-ray lasers from X-FELs integrated into the facility (XCC)

Final Focus parameters	SCRF + Optical Laser	C3 + XFEL
Electron energy [GeV]	250	190
Electron beam power [MW]	10.5	2.1
β _x / β _y [mm]	1.5/0.3	0.01/0.01
γE _x / γE _y [nm]	2500/30	60/60
σ _x / σ _y at e ⁻ e ⁻ IP [nm]	88/4.3	1.3/1.3
σ _z [μm]	300	10
Bunch charge [10 ¹⁰ e ⁻]	2	0.62
Bunches/train at IP	2625	93
Train Rep. Rate at IP [Hz]	5	120
Bunch spacing at IP [ns]	366	5.2
σ _x / σ _y at IPC [nm]	176/37.5	5.2/5.2
L _{geom} [10 ³⁴ cm ² s ⁻¹]	12	180
δE/E [%]	0.1	0.1
L* (QD0 exit to e ⁻ e ⁻ IP) [m]	3.8	1.5 or 3.0
d _{cp} (IPC to IP) [μm]	2600	40
crossing angle [mrad]	20	2 or 20

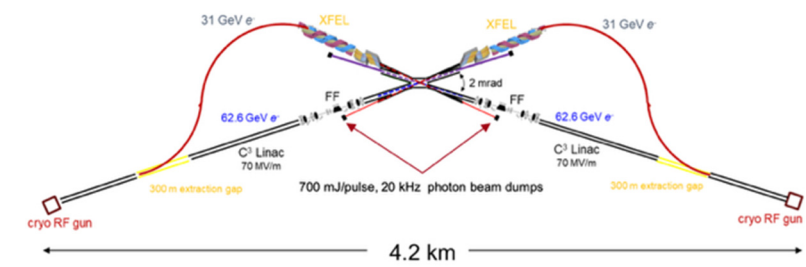
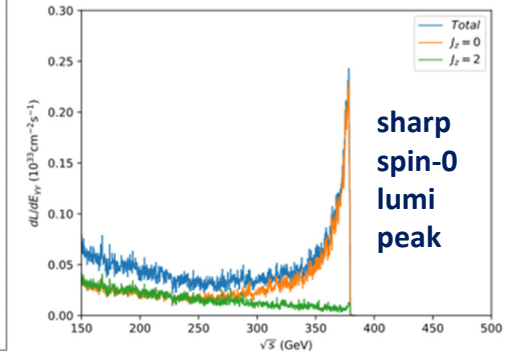

What comes next: Schedule towards a LC@CERN

Prep phase I:

Definition of the placement scenario
Design optimisation and finalization
Main technologies R&D conclusions
(Pre)Technical Design Report - two
IPs at CERN

Construction*:

Civil engineering
Construction of components
Installation and hardware commissioning

2026-28

T0, T0+5

T1, T1+10

T1+11

Prep phase II:

Site investigation and preparation
Implementation studies with the Host states
Environmental evaluation & project
authorisation processes
Industrialisation of key components
Engineering design completion

**Beam-
commissioning**
followed by physics

T0 is determined by a process in 2028-29 to validate the progress and promise of the project for a further development towards implementation.

T1 will be determined by the processes needed, by the CERN Council and with host-states, for project approval and to start construction

*The construction phase is extended with respect to the technically-limited schedules to allow a transfer time into construction, and to avoid the resource conflict between HL-LHC operation and initiating beam commissioning for a next collider

Next Steps – Priorities

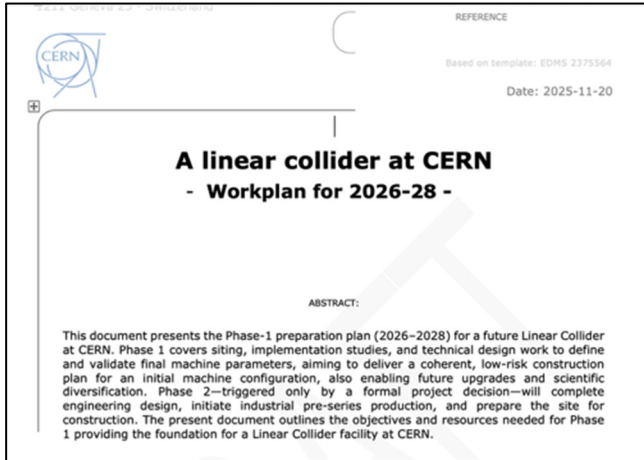

Document requested/drafted in November (CERN focus), being adapted wrt priorities, synergies, resources, collaborations ...

How much of this can be done is currently being discussed:

- A clear priority on HL LHC and corresponding shutdown activities, and preparing the FCC-ee option in the ESPP draft and CERN's planning

Accelerator Design and Parameters

- Define and validate final LC parameters for SCRF and NCRF options through updated start-to-end simulations. It delivers robust machine layouts, performance margins and validates upgrade scenarios, providing essential input to civil engineering, infrastructure, power and cost studies. Ensure/verify that the initial LC design remains compatible with future upgrades.

Implementation: Civil Engineering and Conventional Systems

- Tunnel and shaft layouts, and all conventional systems. It adapts existing CERN layouts to updated machine parameters and energy upgrades, delivering CE and infrastructure layouts fully consistent the accelerator design and parameters. Ensure/verify that the initial LC CE is compatible with future upgrades.

Technology Developments

- Address the main technical risks for the initial LC through targeted R&D on RF systems, drive-beam components, klystrons/modulators, positron sources, damping rings, crab cavities, beam dumps and key components. The objective is to reach TRL 6–7 via extensive international collaboration and shared funding. The ITN covers many of these studies.

Overall

- Deliver “CDR level (or beyond)” reviewable LC design including costing, power, LCA, updated schedule and planning for next Phase, at least 365 GeV (being discussed), cost for initial stage below 10B (also being discussed) ...

Main points

- A Linear Collider at CERN offers a broad physics programme from the Z pole to multi-TeV, with polarised beams and inherent upgradability.
- Two mature technologies presented to the ESPP update process: CLIC 380 (7.2 BCHF, 166 MW) and LCF 250 (8.3 BCHF, 143 MW), including many common studies wrt to implementation at CERN
- A two-phase preparation (2026–2028 and 2028–2034) is foreseen.
- Phase 1 builds on the ITN, CLIC R&D and LCF ESPP studies already made or in progress, and focusses on an improved LC implementation planning at CERN (revise and agree on collider design, parameters, with corresponding CE and infrastructure integration – and with an updated costing, power estimate etc resulting from this). The exact scope of the LC option studies is currently being discussed.
- R&D for the longer term future: Energy upgrades to 550 GeV and beyond 1 TeV achievable within the same/similar civil-engineering footprint feasible, e.g. using CLIC X-band, C³, HELEN, Nb₃Sn SCRF. Also higher luminosity solutions are being studied – e.g. energy recovery systems.



Many thanks to many.

Slides/plots/information from the documents mentioned on slides 18-19.
Several slides “extracted/shortened” from Jenny List’s LCF talk in Venice ESPP
symposium.