



HTS technology development for energy efficient magnets in PSI Large Research Facilities

Stéphane Sanfilippo – Paul Scherrer Institute

Co authors: B. Auchmann, A. Brem, C. Calzolaio, M. Casciello*, M. Duda, Q. Gorit, G. Montenero, J. Kosse, D. Martins, K. Puthran, R. Riccioli, D. Sotnikov, C. Zoller
All PSI members, M. Casciello belongs to the Polytechnico di Torino

Motivation and context
Projects and R&D programs
Technological bricks and infrastructure
Overview of the on-going R&D PSI activities

IPAC'26 – the 17th International Particle Accelerator Conference

Motivation and context



The energy transition of key components in large research infrastructure is essential : Future facilities = high performance, economically viable and environmentally sustainable

Several ambitious programs and events in Europe

- Innovation Fostering in Accelerator Science and Technology (**I.FAST**)
Work Package 11: Sustainable Concepts and Technologies
<https://www.psi.ch/en/scat>
- ESABLIM project, Energy Saving Accelerator and Beam Line Magnets
INFN- LASA (Laboratori Acceleratori e Superconduttività Applicata)- Milano
- SuperEML : HTS magnets for very high fields with energy reduction- EU project H2020-INFRADEV-01-2019-2020 with 10 partners, coordinated by the LNCMI.
- EPITA (Enabling Partnerships for Innovation & Accelerator Technology advancement) : Enabling + emerging technologies for accelerators including HTS , prototype systems, energy efficiency and sustainability- EU project consortium with 16 countries+ CERN+ESS, 43 beneficiaries.
- iRIS (Intelligent Research Infrastructure sustainability): Sustainability methodology + pilots in Research Infrastructure components with AI- HORIZON-INFRA-2025-01-TECH-01 (2026-2029)
- ESSRI : Series of workshops for Energy for Sustainable Science at Research Infrastructures workshops



Large Research facilities & CPT at PSI

Engines of discovery= *Machine generating "probes"*
to examine the matter structure



High Intensity Proton Accelerator Complex

590 MeV Proton
Cyclotron



Spallation Neutron
Source (SINQ)

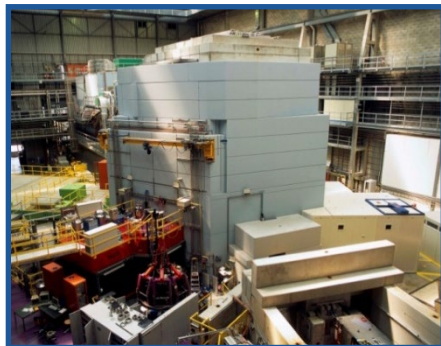

Swiss Muon
Source (SμS)



Swiss Light
Source (SLS 2.0)

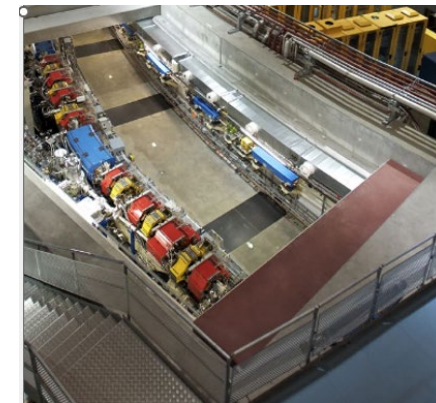
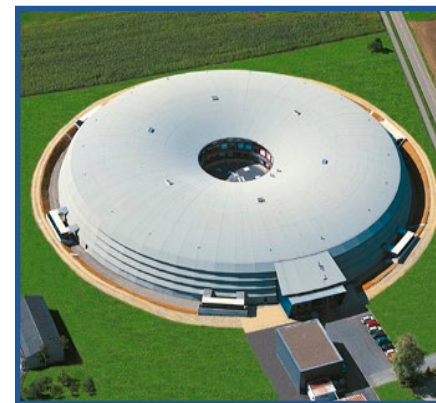

Swiss Free
Electron Laser (SwissFEL)



Protons beam
therapy



Photons
Protons
Neutrons
Muons

Microscopic insights
into materials

Energy Management in PSI Large Research Facilities

– Operation and Upgrade



High Energy Demand of PSI Large Research Facilities:

- High Intensity Proton Accelerator (HIPA)
- Swiss Free Electron Laser (SwissFEL)
- Swiss Light Source (till October 2023)
- PROSCAN- Tumor treatment facility using protons (2 beamlines with gantries)

Strong contribution from resistive magnets to power consumption (HIPA -2.6 MW, 26 %)

Trends

- Expected Increase in electricity cost
- Growing CO₂ Footprint

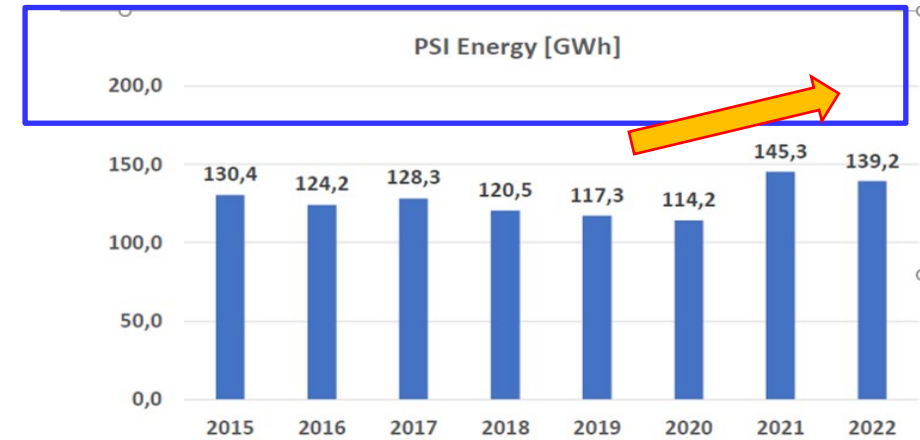

PSI peak power: 22.5 MW

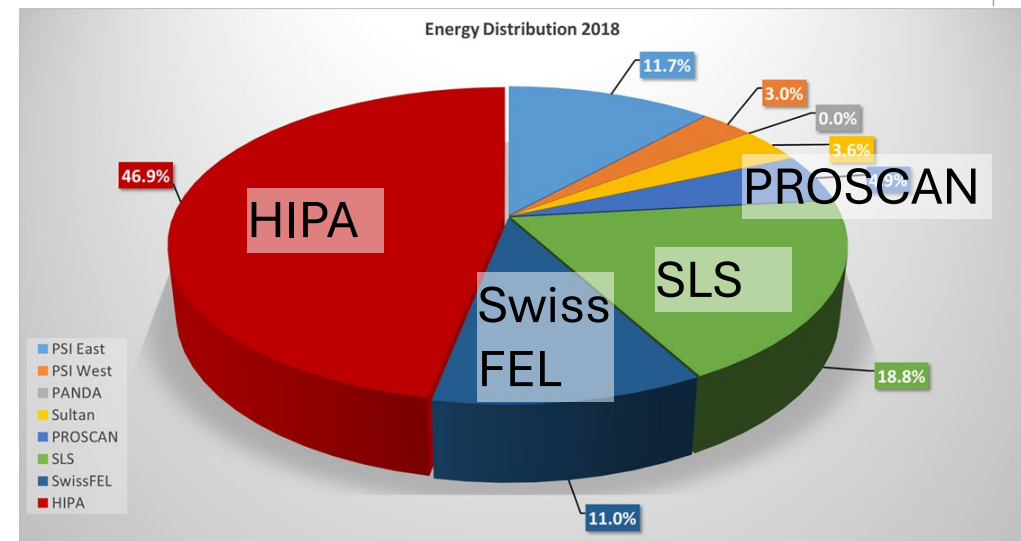

PSI energy / year ~ 140 GWh

Upcoming upgrade of HIPA Project IMPACT = HIMB + TATTOOS

Courtesy of Mahir Dzambegovic

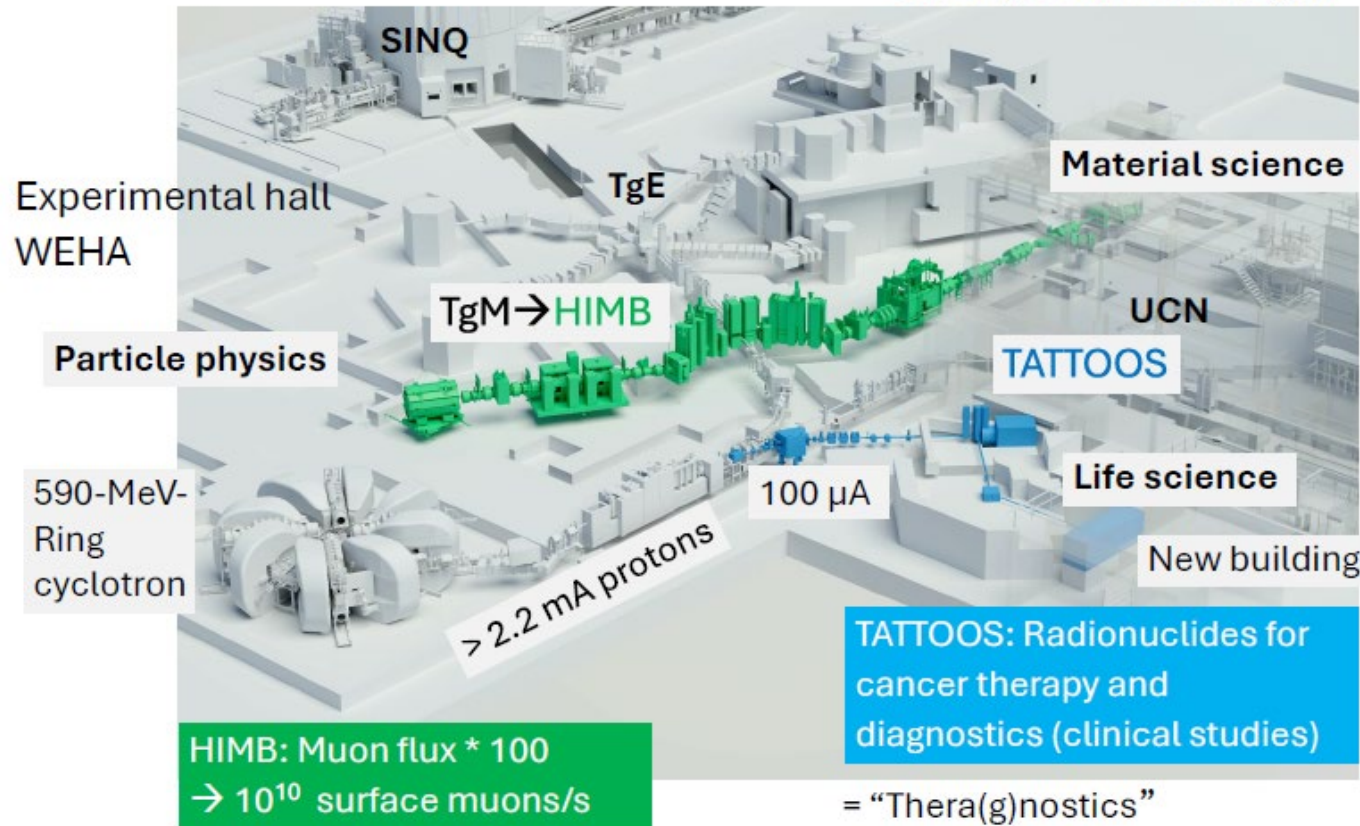

Volume HIMB

PSI Bericht Nr. 25-02
December 2025
ISSN 3042-6391

[https://www.dora.lib4ri.ch/psi/dload/psi:78449/PDF/Aeschbacher-2025-IMPACT_technical_design_report-\(published_version\).pdf](https://www.dora.lib4ri.ch/psi/dload/psi:78449/PDF/Aeschbacher-2025-IMPACT_technical_design_report-(published_version).pdf)

Timeline of IMPACT: 2027/28 HIMB installation ; 2029/30 TATTOOS installation

New target two new beam Lines at HIPA

- to increase the Muon rate production by a factor 100 (**HIMB**)
- create radioisotopes suitable for advanced cancer treatments (**TATTOOS**)

Magnets in Operation at PSI

<i>Machine</i>	<i>Magnet number</i>	<i>In operation since</i>
HIPA	300	1974 (Ring) 1984 (Inj. II) 1996 (SINQ)
PROSCAN	100	2004
Gantry 3	13	2017
SwissFEL	373	2017&2021
SLS2.0	1019	2025
Total	1805	
HIMB TATTOOS	34	2027 & 2029

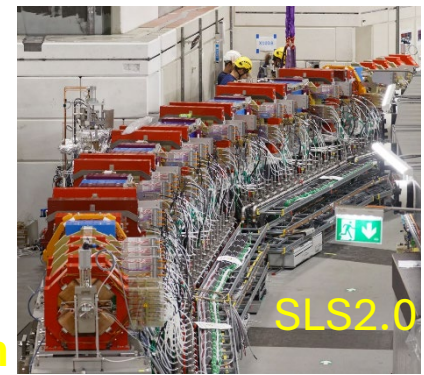
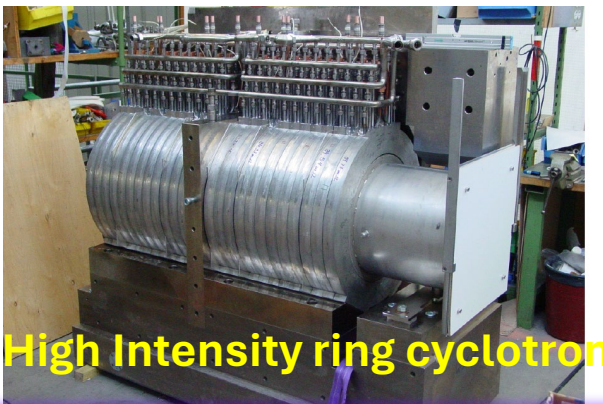
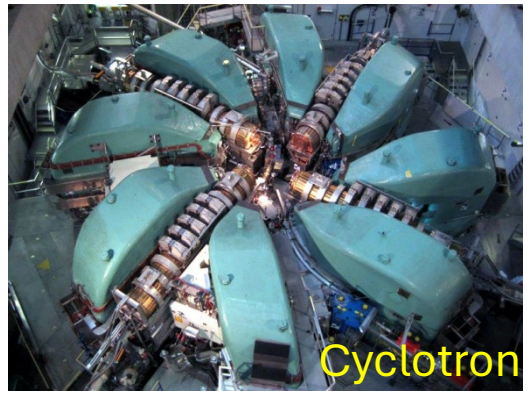

80 % are Electromagnets - 385 Permanent Magnets (SLS2.0)+ one superconducting cyclotron

Requirements for Accelerator Magnets in 21st-Century Research Facilities

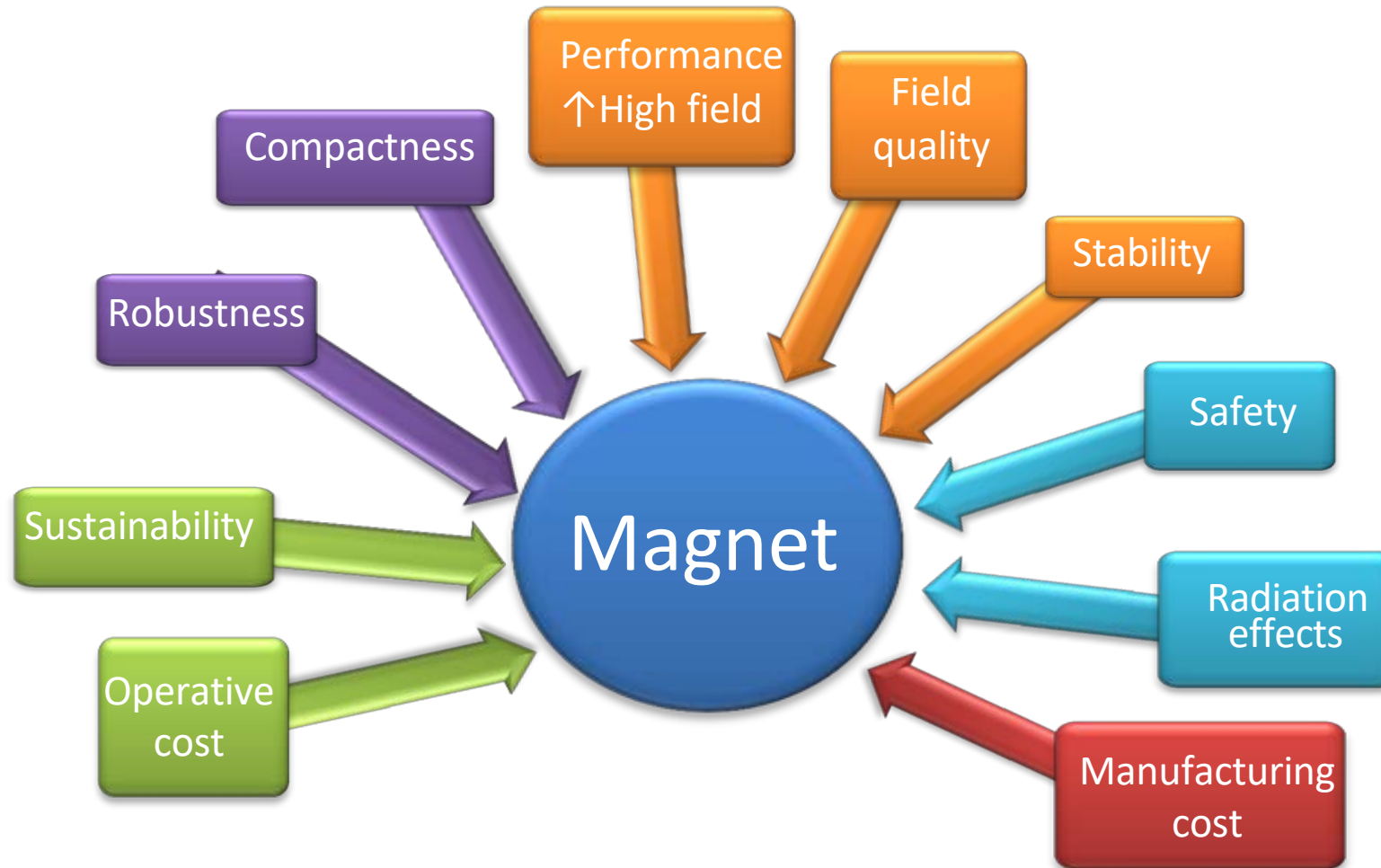

Operative cost : Electricity and maintenance
Robustness : Manufacturing quality + radiation damage

Energie Transition for the PSI accelerator magnets: The proposed strategy

Starting Situation	Proposed Solution
Low field High magnetic density Low radiation (e.g. Light Sources)	Permanent magnets (NdFeB) (applied in SLS2)-PROkW program
Moderate/high field High energy consumption Highly radiation-exposed environment	Superconducting magnets-conduction cooled

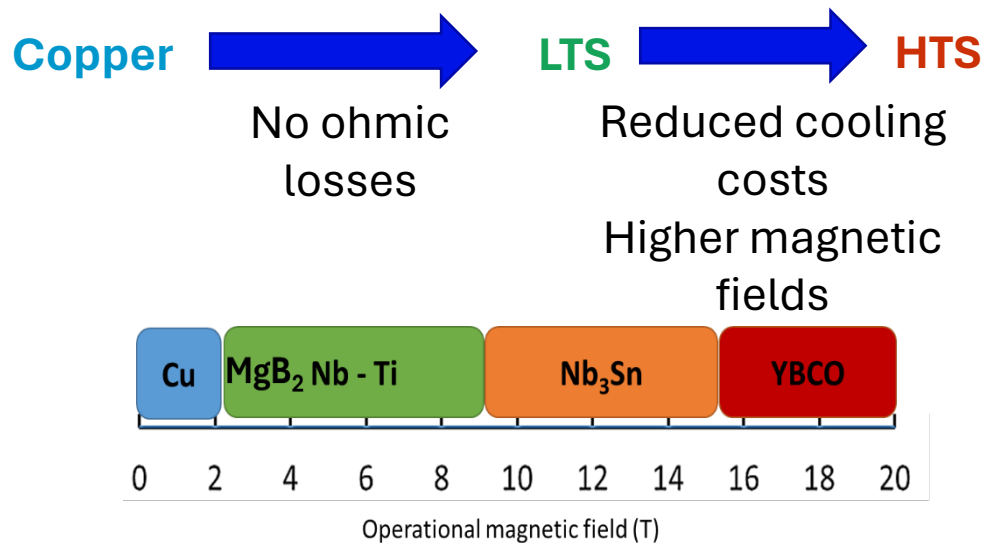

Factors:

- 1. Operating conditions:**
 - Field strength
 - Beam energy deposition
 - Space
- 2. Economics:**
 - Initial capital cost
 - Cost saving in electricity
 - CO₂ emission reduction
- 3. Radiation damage**
 - Superconductors
 - Insulation

Energy Transition for the PSI accelerator magnets

And sustainability?



Planetary Boundaries (2023)

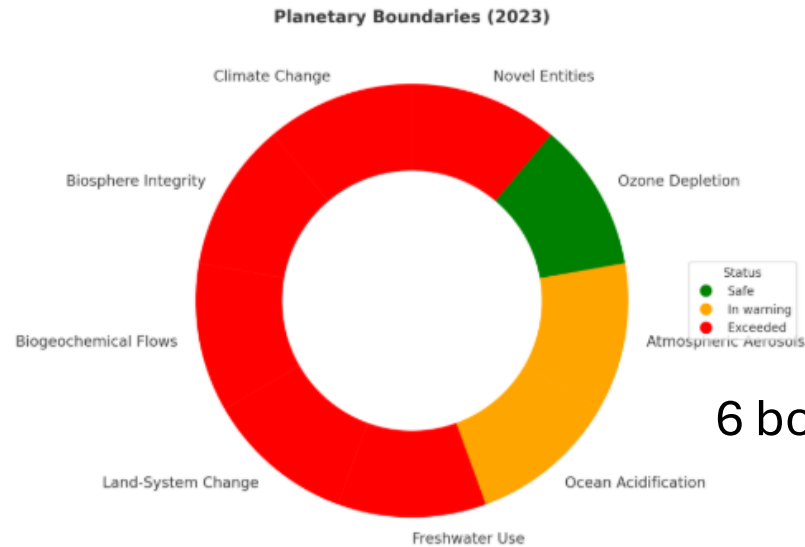

6 boundaries exceeded (2023)

Johan Rockström et al, Nature 2009

- **Production phase** → negative impacts on planetary boundaries (water, materials, extraction pollution....)
- **Use phase** → positive impacts, energy savings, footprint reduction, supporting medical application

The choice of REBCO tapes, insulation, impregnation, soldering, coatings, copper stabilizers and cryogenic components should also be evaluated through **LCA**

Factors:

1. **Physics and performance:**

- Operating conditions (J_{ce} , T_{op})
- Field strength beam energy deposition
- AC losses & Field Quality
- Space

2. **Economics & strategic**

- Conductor cost and availability
- lifecycle costs (CAPEX vs OPEX)
- long-term compatibility with upgrades.

3. **Environmental & Reliability**

- Radiation damage
- Quench protection
- Cooling & powering

4. **Sustainability**

- LCA on raw materials
- Process and manufacturing
- Recyclability
- Reduced waste protocols

HTS (conduction cooled) superconducting magnets Versus resistive and LTS ones

Advantages

- Increased performance
- Compact design
- Saving electric consumption
- Reduced cost for power supply

Drawbacks

- Higher capital cost
- Cryogenics
- Quench detection system

Resistive magnets

- **Thermal stability**
*Large temperature margin
(including beam deposited energy)*

- **Top > 20 K**
 - Smaller $P_{\text{electric}} / P_{\text{cryogenic}}$ ratio
 - Reduced thermal losses

LTS magnets

- **Not multi-filamentary architecture**
Reduced field quality

- **AC losses in time varying field**
 - Hysteresis loss
 - Eddy currents
 - Coupling currents

- **Radiation damages**
 - Limits for superconductor operation?
 - No organic insulation

LTS & HTS technology development : The foundational diagram

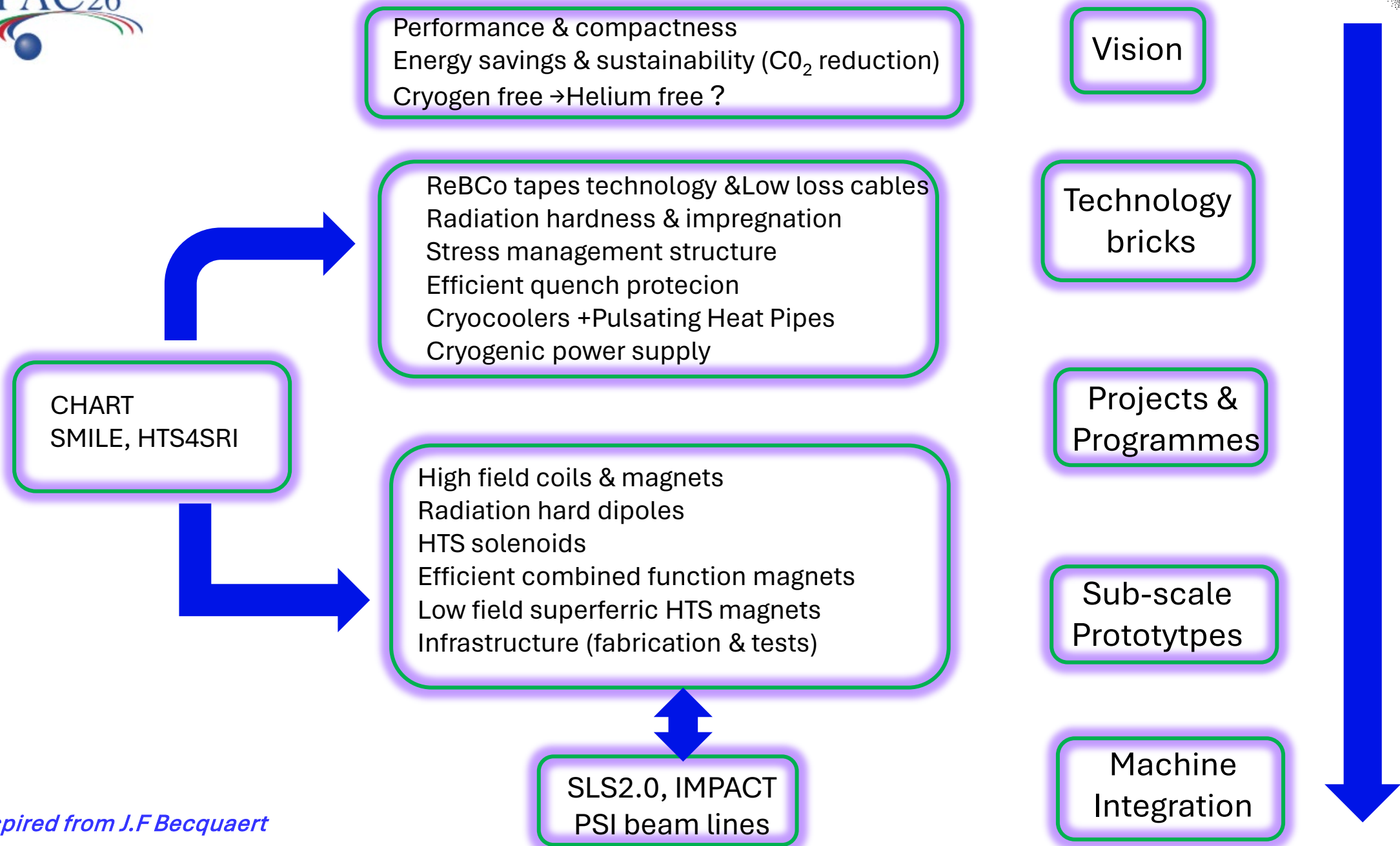



3 Accelerators and 4 Users facilities
Power from the magnets : 2.6 MW- 26 %

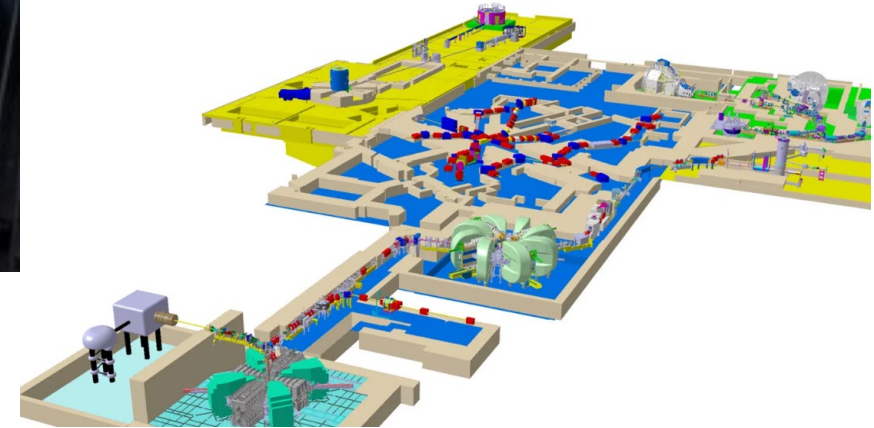

Long term plan : Replace progressively high consumption resistive magnets with HTS magnets

Efficient Superconducting Magnets in the High Intensity Proton Accelerator

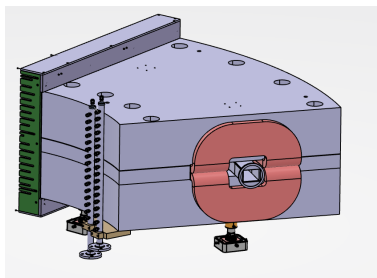

AHC	
Power	128 kW
Field	1.564 T
Integral	2.8 Tm
Size	2x1.5x0.8 m
Weight	12.5 t

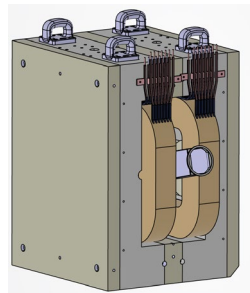

AHM, AHN	
Power	67 kW
Field	1.5 T
Integral	3.75 Tm
Size	2x1.5x1.2 m
Weight	22 t

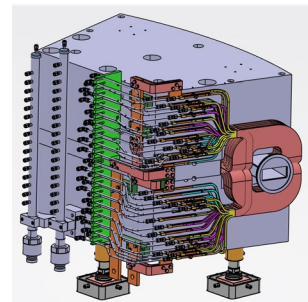

AHB	
Power	189 kW
Field	1.8 T
Integral	2.9 Tm
Size	1x0.7x0.7 m
Weight	4.2 t

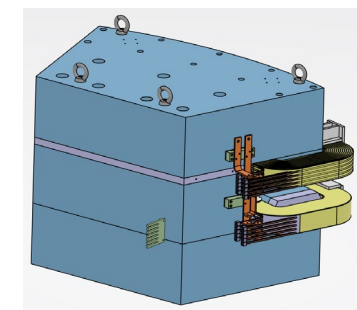

AHD1, AHD2	
Power	32 / 74 kW
Field	1.2 / 1.15 T
Integral	2.2 / 2.3 Tm
Size	2x1.2x1.5 m
Weight	19 t

Saved Energy (MW/y per magnet)

481 MWh

238 MWh

725 MWh

267 MWh

Minimum time of operation: 20 years

Saved energy with one SC magnet from 4.5 GWh (183 Tons CO₂e) to 14.5 GWh (590 Tons CO₂e) after 20 years of operation

Support from projects and programs



1. PSI projects and R&D programs

- SLS2.0 , IMPACT
- Swiss Accelerator Research and Technology (CHART)
- Superconducting Magnet to Improve the Efficiency of Large research facilities (SMILE)
- EU project HTS4SRI (HTS For Sustainable Research Infrastructure)

These activities are complementary and are being developed in a synergistic manner.

2. Infrastructure development and beam line upgrade

- Supporting infrastructure, testing, and integration capabilities
- PSI Positron Project (P3) (SwissFEL) , Muon beam line, Neutron scattering...

3. International Collaboration and Innovation Ecosystem

- Collaborations with CERN, research institutes, and industry partners.
- Co-development with the partners of the innovation environment “Park Innovaare”.



CHART is an umbrella for Swiss contributions to the science and technology of the FCC accelerator, **a Swiss national science priority**



Initial agreement in October 2015

- Co-funded by SERI, ETH-domain and partners CERN, PSI, EPFL, ETHZ, UniGE
- Home institute : PSI
- **> 30 projects**

Goals:

- development and innovation of future accelerator technologies **for the Future Circular Collider**;
- synergy with synchrotron light sources, medical, industrial, and energy/fusion applications;
- emphasis: technologies and demonstrators for **high field magnets and FCC-ee injector**.

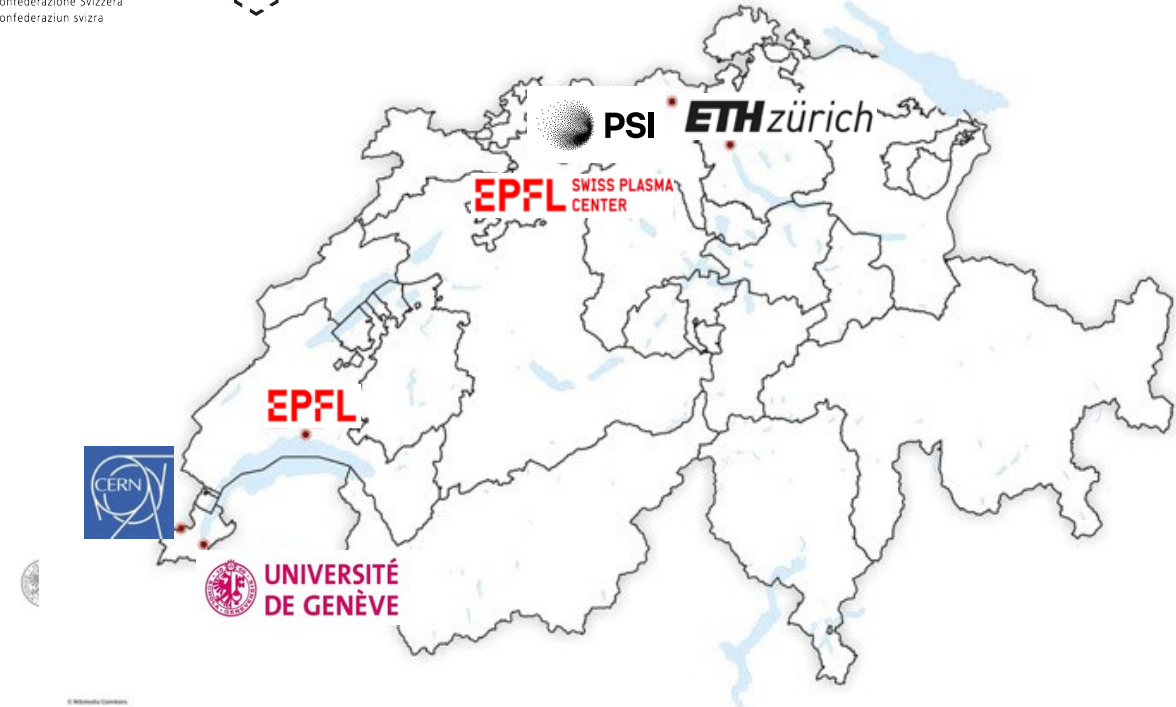
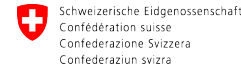

<http://chart.ch>



PSI MAGDEV program : High field magnet technology, design, manufacturing process & infrastructure for demonstrator construction using LTS and HTS

SMILE initiative (2025-2026)

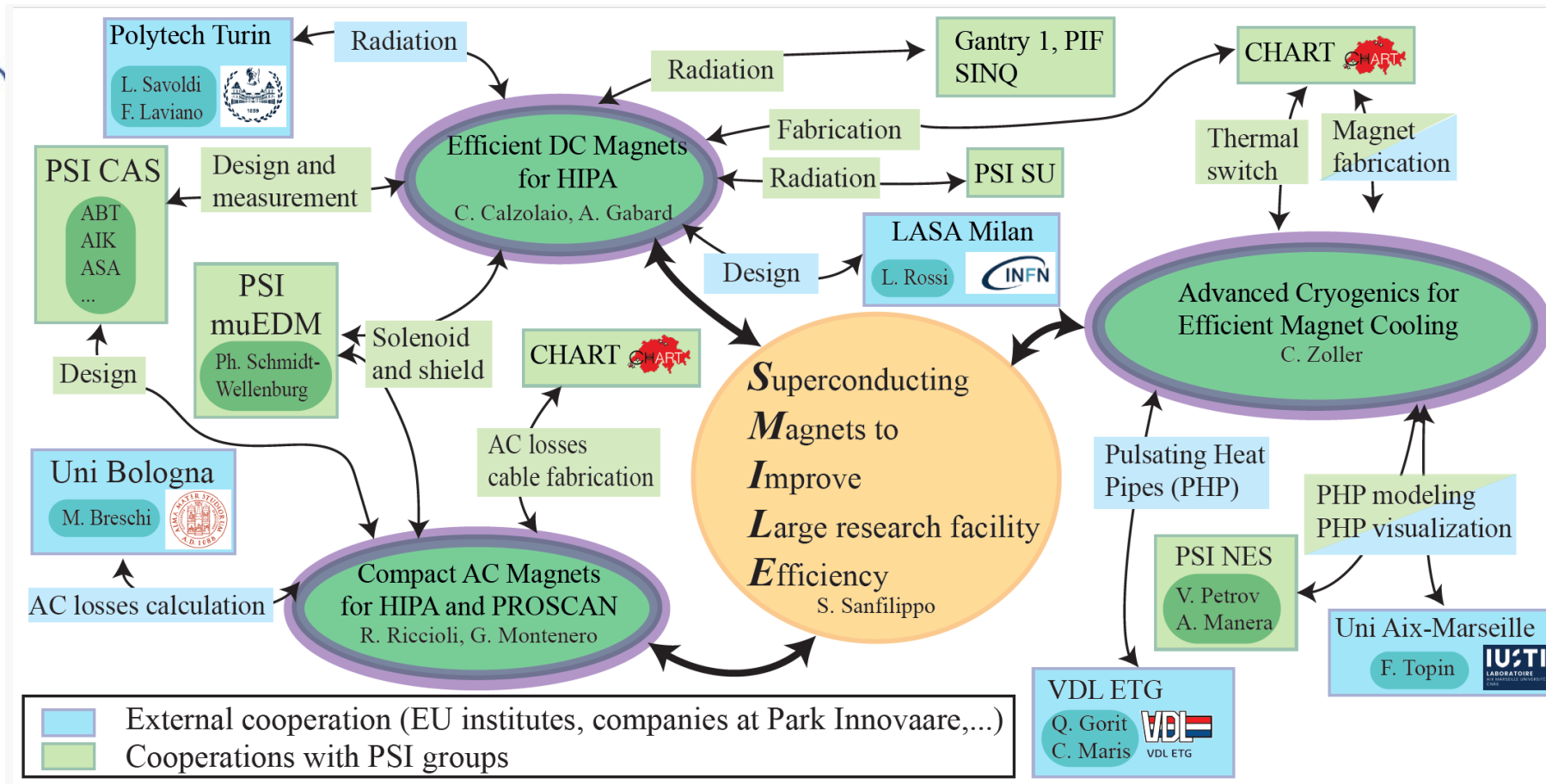

Three poles of activities (partially funded) : DC magnets, AC magnets and Efficient cooling

Pole 1: Irradiation effect on HTS magnet (March 2026)



Pole 2: Numerical and experimental studies of CORC conductors (2026)



Pole 3: Pulsating Heat Pipes with HTS coils



and..... the EU funded project HTS4SRI (2026-2029)



Efficient and sustainable HTS accelerator magnets

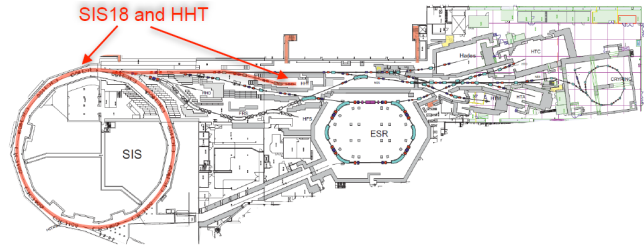

normal conducting magnet focusing quad
consuming a lot of energy (~ 60 kW)
→ HTS one

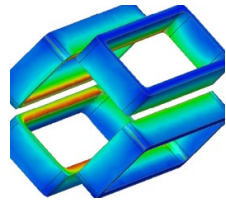

FFQ coils : HTS Final Focusing Magnet System at GSI heavy ion synchrotron SIS18

FFQ coils	
Magnetic Field peak	4 T
Aperture	200 mm
Operating Temperature	20-40 K
Energy Saving	~ 50 %

ADHTS : 4 T HTS dipole demonstrator for the TATTOOS beam line

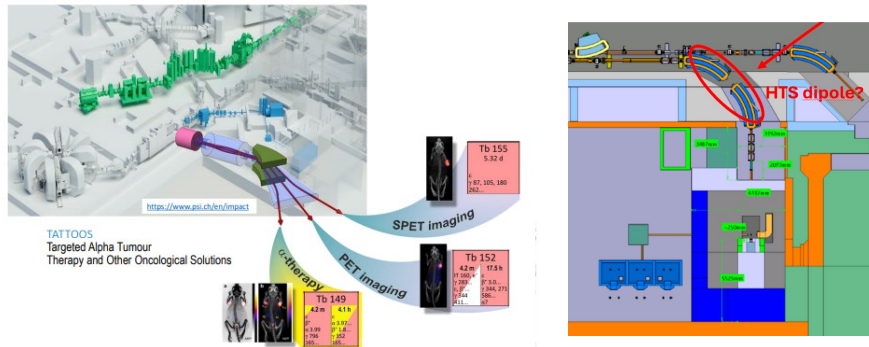

ADHTS dipole	
Magnetic Field	4 T
Bending Angle	80 °
Gap	100 mm
Expected Energy Saving / per year	0.2 GWh (~50 %)

SQCM: HTS sextupole & quadrupole for FCC-ee (~7,600 NC magnets → ~2,900 combined QSCMs)

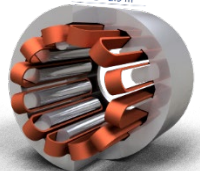
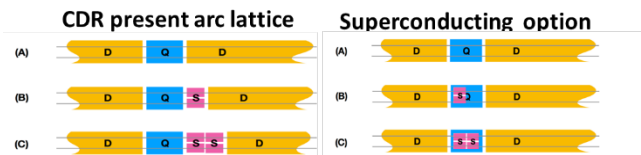

Magnet	Quadrupole–Sextupole Combined Magnet
Design type	Superferric, flat REBCO racetrack coils, dodecapole iron yoke (2T peak field)
Op. Temp	50–65 K (cryocooler-based refrigeration); extendable to 65 K -77 K (LN ₂ -derived cooling)
Cooling Approach	Conduction-cooled, distributed cryocoolers (FCCee-CPES compatible)
Manufacturing strategy	Planar coil geometry , robotic winding, AI field quality optimization
Scalability	20 '000 coils for FCC-ee
Energy savings	0.25 TWh per year

 **Duration:** 4 years (2026–2030)
Start : 01 September 2026
 **Participants:** 8 institutions
 **Budget:** 7.57 M€ total – EU contribution 5.0 M€ – In-kind 2.57 M€ (52 % of the EU contribution)

- WP1: Coordination & dissemination**
- WP2: LCA & Sustainability**
- WP3: HTS conductor tests and subscale coils**
- WP4: Design and Engineering**
- WP5: Coils & demonstrator manufacturing**
- WP6: Qualification and testing**

Work Packages: 6 (WP1–WP6)

Partner	Role / WP leadership
PSI (CH)	Coordinator, WP1 & WP3 lead
Bruker Biospin (CH)	Co-lead WP2
CEA (FR)	Co-lead WP1 & WP5
CIEMAT (ES)	Co-lead WP2
CERN (CH)-Int. Org.	Lead WP6
GSI (DE)-ESFRI	Co-lead WP4
INFN (IT)	Co-lead WP4 & WP5
Univ. Milano UMIL (IT)	Co-lead WP4 & WP5

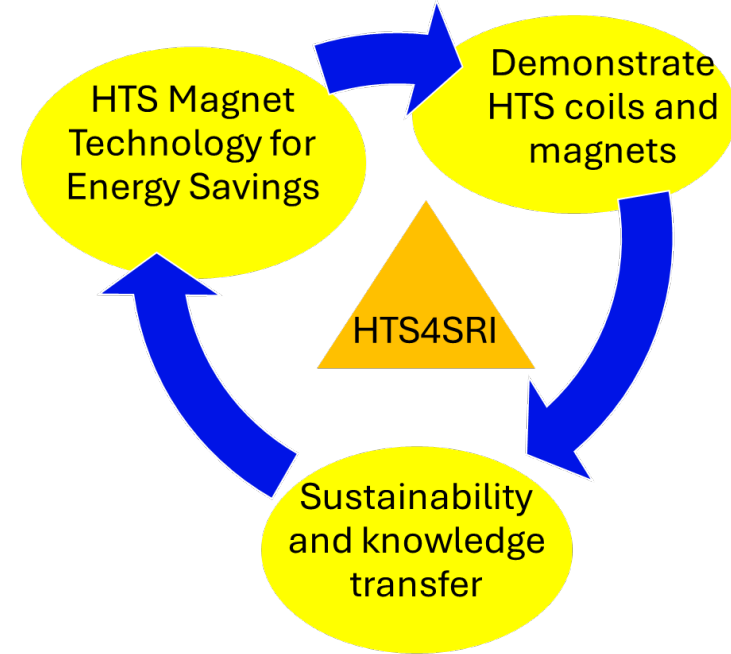

Kick off meeting: 7-8 October 2026 at PSI

Technological building bricks and infrastructure

Conductors and cable
Conduction cooling and Pulsating Heat Pipes
Laboratories for superconducting magnet development and tests



Enabling Efficient HTS Magnets for PSI Large Research Facilities: Technology Pathways

Conductor, cable architectures

REBCO stacked tapes, non-insulated tapes, CORC, CORT, low-loss cable design

Magnet design, manufacturing & assembly processes

Mechanical design & stress management, thermo-mechanical behavior, field quality
Coil winding, soldering, impregnation, mechanical assembly, instrumentation

Cryogenic systems & thermal management

Conduction cooling with cryocoolers+ Pulsating heat Pipes

Reduction of the thermal losses from current leads

Cryogenic power supply (CPES)

Radiation hardness

HTS tapes and full coil test under radiation

Efficient magnet design & integration

Compactness, operating conditions to reduce energy consumption,
full design-to-demonstrator value chain

Quench detection & protection

Adapted to HTS and NI coil behavior

Sustainability

Life cycle assessment of the magnet design and construction



Integrated value -chain approach

Practical superconductors used for PSI magnets



NbTi rutherford cables

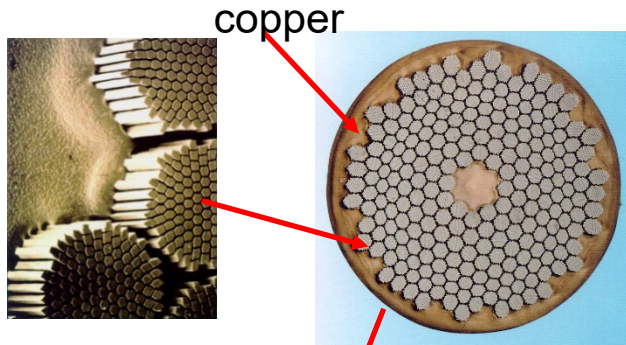

NbTi filaments strands

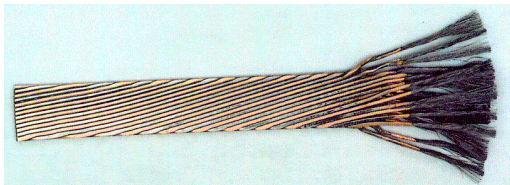
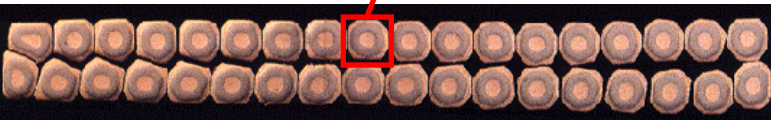

Rutherford cable

Nb₃Sn cable

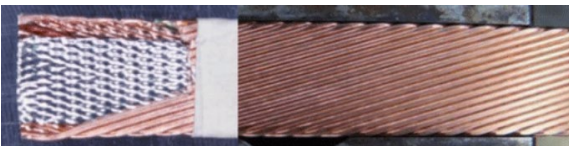

Rutherford cable
(21 high-current-density strands)

ReBCO: Insulated and non insulated tapes

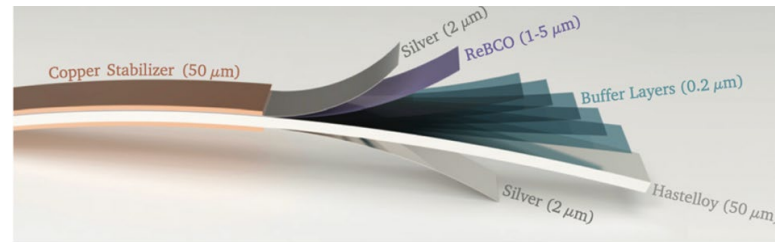

4 mm width
Non Insulated
ReBCO tape

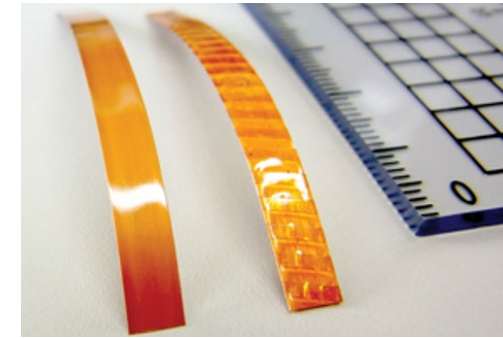

Tape and stack of tapes

Coated conductors :

- ReBCO
- HTS film of 1-2 mm thickness deposited on one side of the substrate

Striated tapes

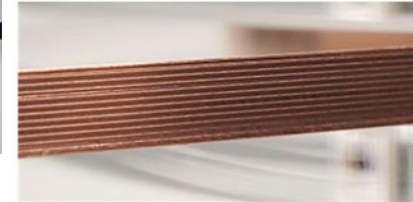

ReBCO cable with CORC(T) or twisted stack of tapes

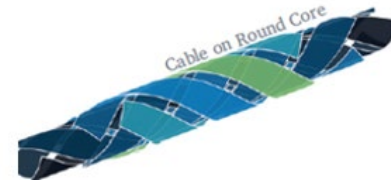

Twisted stack of tapes



CORC or CORT: Cable On a Round Copper Core (Tube)

- Increasing the current;
- Allowing current sharing between tapes;
- Reducing AC losses;
- Improving mechanical properties.

One example of synergy: Non insulated HTS technology for high field magnets in PSI beam lines

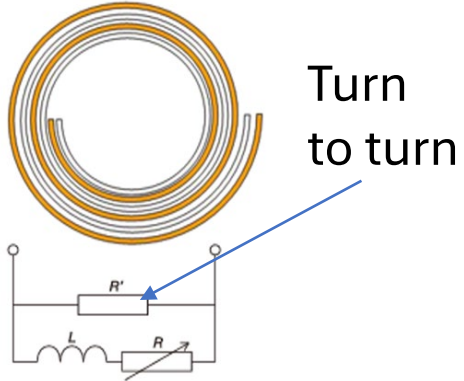

Insulated coil: $R' \sim \infty$

Metal-insulated coil: $R' \gg 0$

Non-insulated coil: $R' \sim 0$

- + Very high current density, → compact winding, lower cost
- better mechanical and thermal conductivity
- Simpler passive protection

- Slow charging and discharging for large L, $\tau = L/R$

- Need to control turn-to-turn contact resistance

- screening-current effects

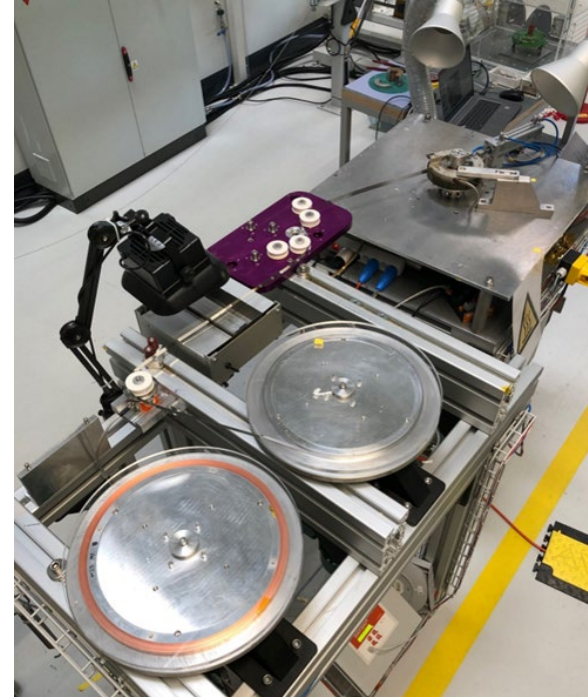
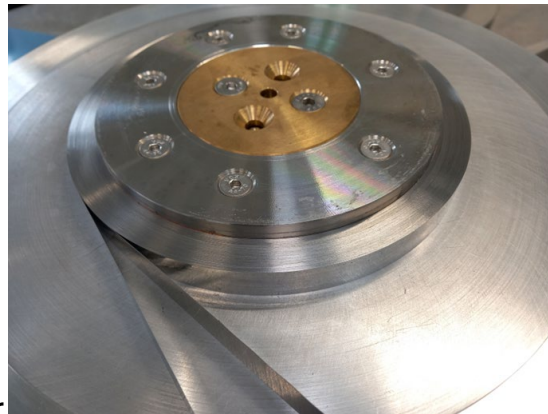
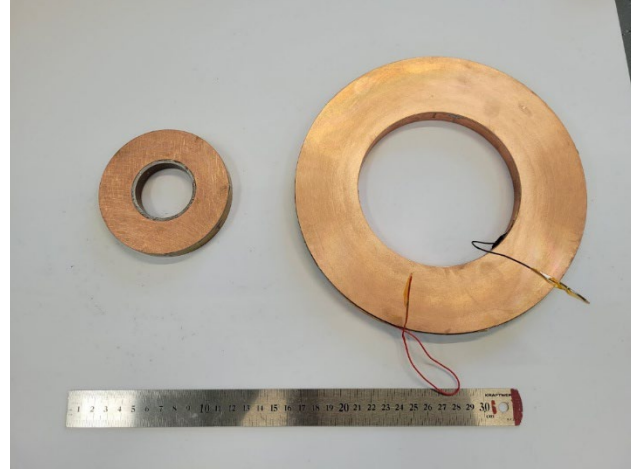

Rapidly developed infrastructure at PSI, & parts of soldering technology via license agreement with

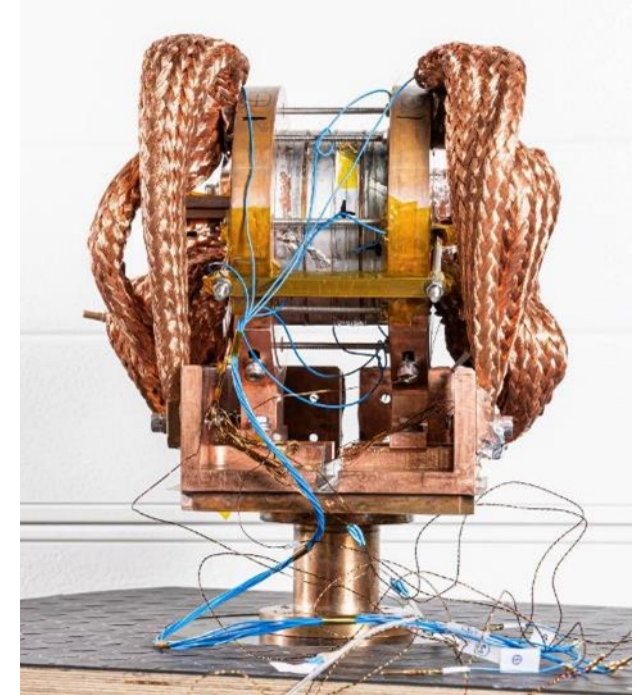

4 coils demonstrator
18 T @ 50 mm cold bore, 10 K

NI HTS technology used for high field solenoids in future PSI beam lines

Choice for single PSI LTS & HTS magnets

Advantages (+)	Disadvantages (-)
No liquid helium plant required	Limited cooling capacity (very low COP)
Compact and modular system	Long cooldown time
Simplified installation	Mechanical vibrations
Small helium consumption	Limited by the thermal contact between the coil, thermal links, and cryocooler cold head.
Lower operational complexity	Failure impacts operation
Ideal for HTS (T>20 K)	Not suited for large heat loads
Improved safety (no liquid helium)	Requires redundancy
Potential cost reduction	Compressor maintenance

<https://shicryogenics.com/product-finder/>

Use of dual inverter for energy-saving operation of GM SHI cryocoolers, with regulation frequency of compressor allowing cooling control and reduced electricity consumption.



RDEK-500B + F70 compressor

Single stage

Power capacity : 45 W @ 20 K (50Hz)

Power consumption : 6.6-6.9 kW at 50 Hz



RDE418D4 + E77 compressor- 2 stages

Dual inverter: f ~40-60 Hz

Power capacity :

1st stage : 42 W @ 50 K (50Hz), 50W (60Hz)

2nd stage : 1.8 W @ 4.2 K (50Hz), 2W (60Hz)

Power consumption :

- 6.5 kW at 50 Hz

- 7.5 kW at 60 Hz

Pulsating Heat Pipes for HTS magnet cooling

(partnership with VDL ETG-ParkInnovaare)



PSI beam lines: SC magnets cooled with cryocoolers can be installed (space problem)

Challenge: Transport heat efficiently from HTS and LTS coils to cryocooler

Proposed solution: Use Pulsating Heat Pipes (PHP) filled with neon or nitrogen (for HTS) and helium (for LTS)

Principle: 1) Highly efficient **passive** device **transferring latent heat** from “warm” evaporator (HT coils) to cold condenser using thermally induced two-phase flow

2) **Convection**: Oscillation of liquid slugs and vapor bubbles

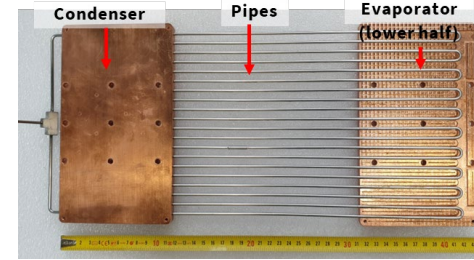
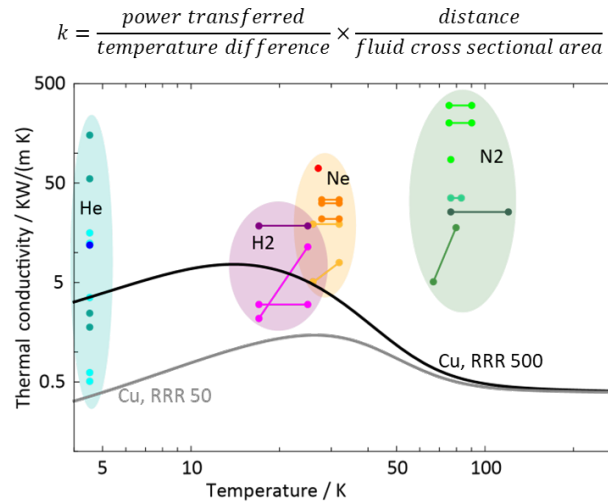
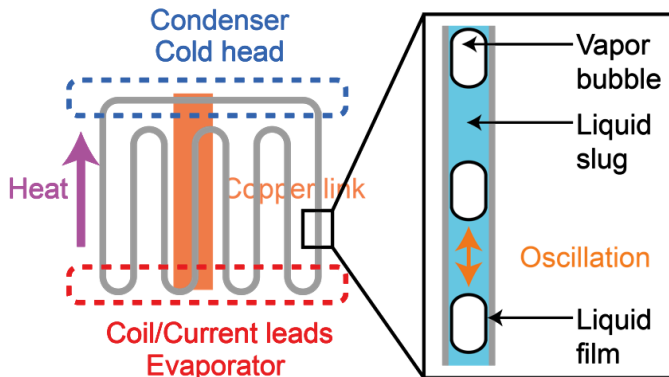

Test with 2 copper plates

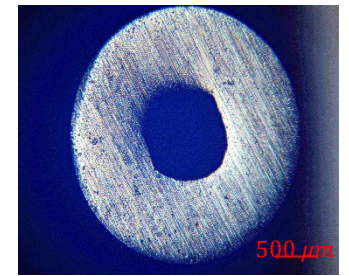

Pipe cross-section

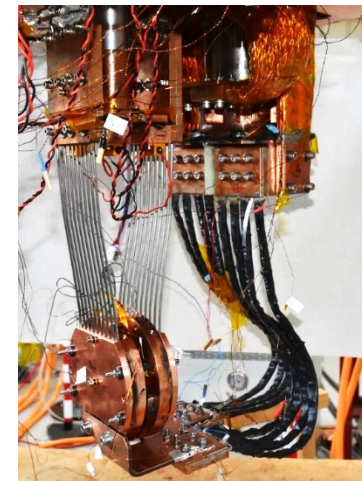

Two PHPs in parallel embedded in an insulated HTS coil

Highlights

- Fabrication of PhPs working with Neon and N₂ connected to HTS coils (evaporator) and cryocoolers (condenser)
- Experimental campaigns with Ne and LN₂
- Successful cooldown and operation of HTS coils with a non-insulated coil (DC operation) and with an insulated coil (AC operation)

Heat transfer improved compared to copper thermal link :
Thermal resistance between the cryocooler and the coil decreased of nearly **80%**

Synergy with CHART : MagDev laboratory for superconducting magnets (2020-2026)

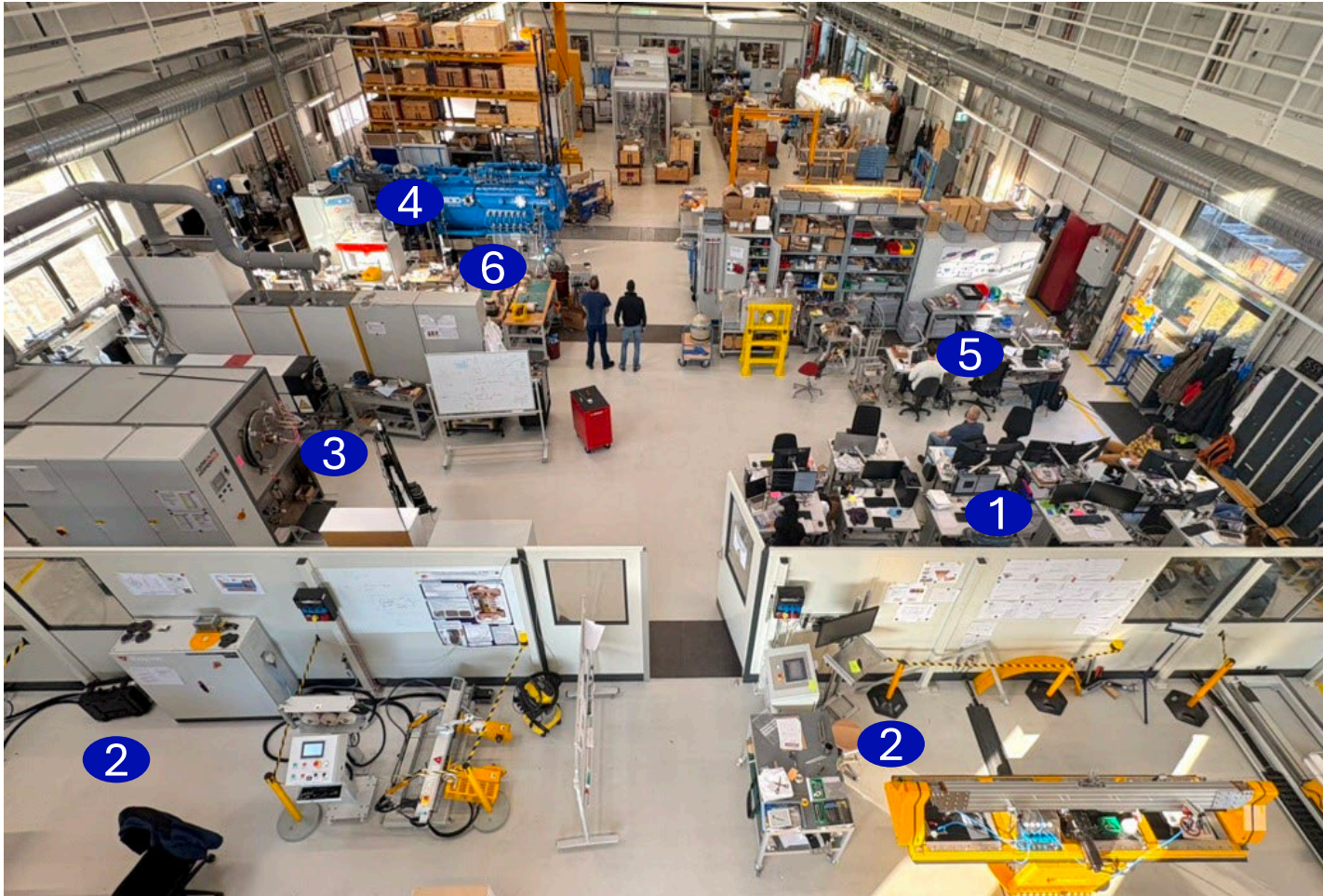

Design (1), coil winding (2), heat treatment (3), impregnation (4), magnet assembly (5), instrumentation (6)



Douglas Araujo
Engineer LTS



André Brem
Material Scientist



Jaap Kosse
Engineer ReBCO



Anna Stampfli
Technician Process



Dmitry Sotnikovs
Design Engineer ReBCO



Jürgen Schmidt
Technician HTS



Inês S. P. Peixoto
Magnet Engineer



Christian Lindner
Technician HTS



Kirtana Puthran
Engineer ReBCO



Colin Müller
Mechanic LTS



Thomas Michlmayr
CAD, Technical Design



Nicolas Kehl
Technician LTS



Alejandro Carlòn Zurita
Technician HTS, CAD



Sascha Röthlisberger
Laboratory technician



Joep Van den Eijnden
PhD Student



Matteo Crescenti
PhD Student

1

Financed by CHART 2 & 3 program

Courtesy Bernhard Auchmann

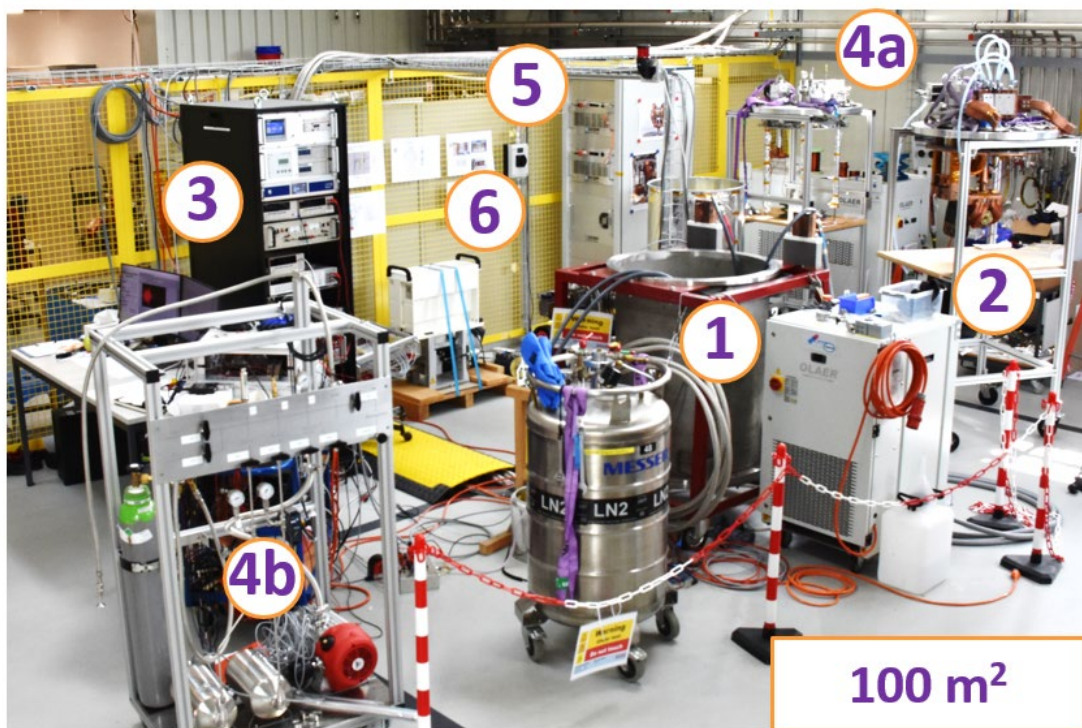

1: Cryostat

- Thermal radiation shield
- Vacuum pumps
- Cryocoolers (RDK-415D/418D and RDK-500B)

2: Test setup for superconducting HTS and LTS coils

- RRR, T_c and th. cond. test
- NI HTS coils test (18.2 T)

Versatile infrastructure for tests:

- $4.5\text{K} \leq T \leq 65\text{ K}$ (cold heads)
- In a 77 K LN₂ bath

3: Electronic rack

- vacuum control/monitoring
- temperature control/monitoring (16 Cernox/ Pt1000 sensors, PID controller)
- voltage signals recording (2 nanovolt/64 high precision/64 fast sampling channels)
- quench detection system (CERN uQDS with PSI modification)

4: Test setup for cryogenic pulsating heat pipes (PHP)

- 10 and 20 tube neon PHP (with VDL ETG)

5: 2 kA ± 10V power converter

6: Quench protection

- mechanical switch (~4 ms) with varistor



*Magnetic measurement system
3D hall probe*

Panel of HTS magnet activities at PSI

HTS high field magnet program for FCC-hh
Efficient HTS combined function magnet for FCC-ee
High field solenoids for PSI beam lines
Radiation hardness study

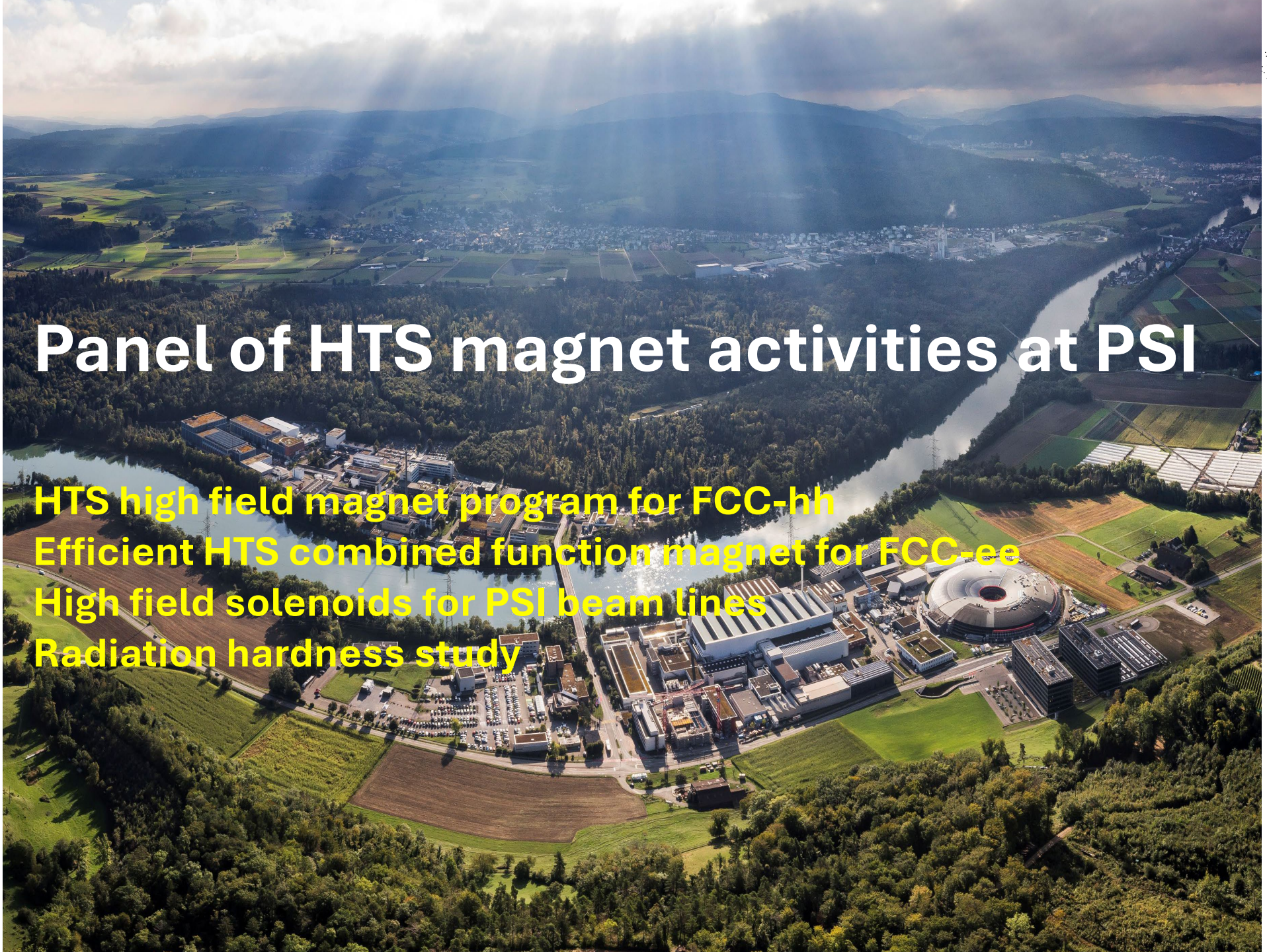

Useful experience : Two 5T NbTi Superbends for SLS2.0 (2026)

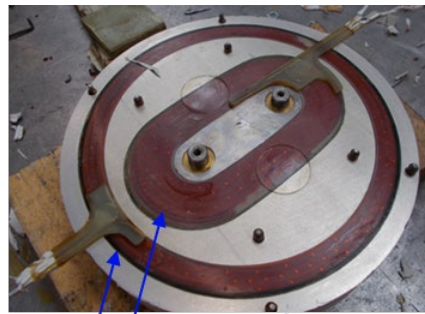
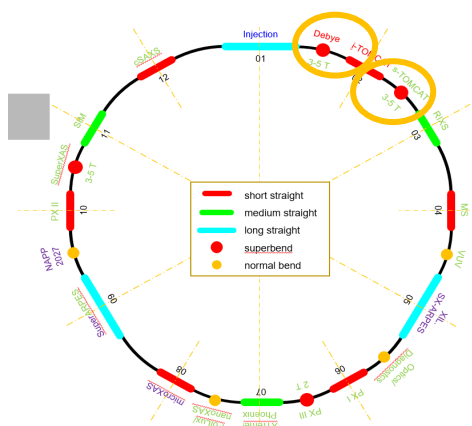

solenoid racetrack NbTi coils

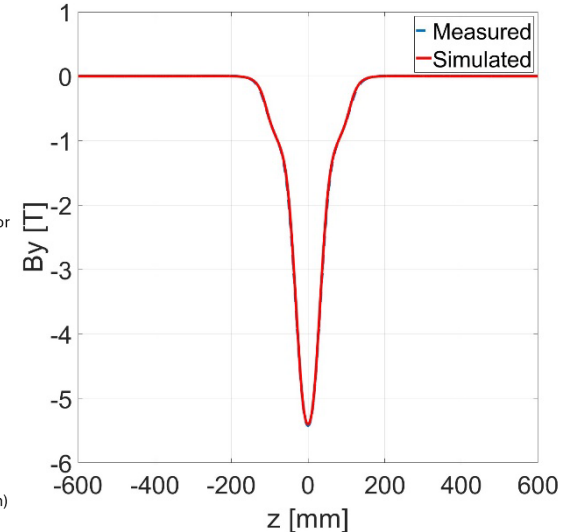
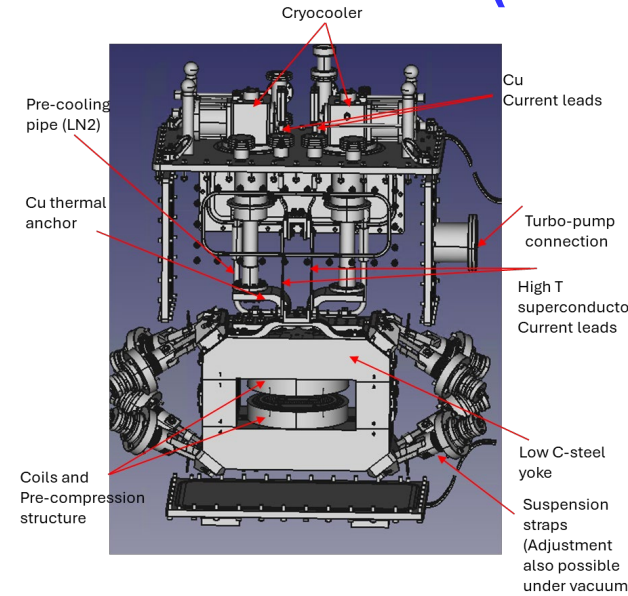

SCA field profile, peak field at 5.4 T

- 2 superconducting Superbend magnets will replace the 3.1 T one of SLS.
- 2 operating scenarios: 3T and 5T peak field.
- Electromagnetic design & magnet qualification at PSI
- Cryostat design and magnet manufacturing by the company SIGMAPHI (F)
- Power tests and magnetic measurements on-going
- Installation foreseen end of 2026

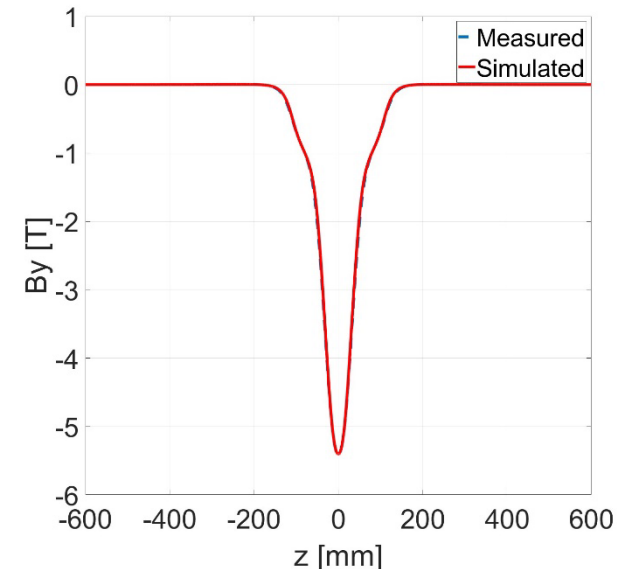
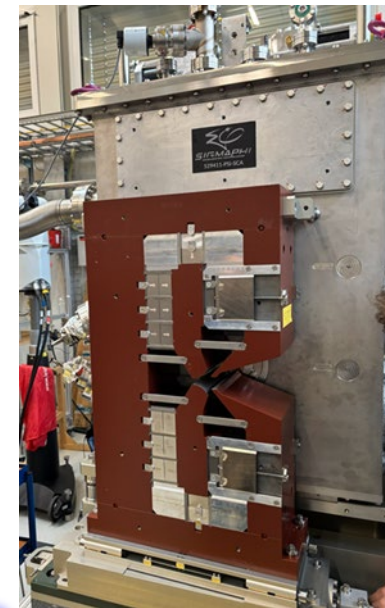
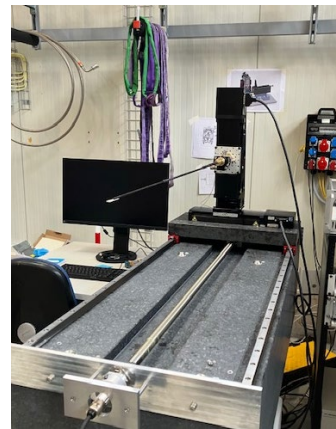
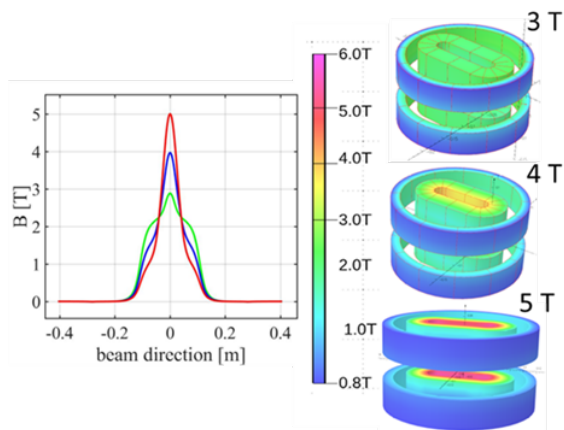

SCB field profile, peak field at 5.4 T

SLS2 vs SLS SB: 170kW x 6800 operating hours ; 0.6 GWh per year
Savings for 15 Years : 9 GWh

Cold test with quadrupole

MagDev2, MagDev3 (RS1, RS2)

Prototype

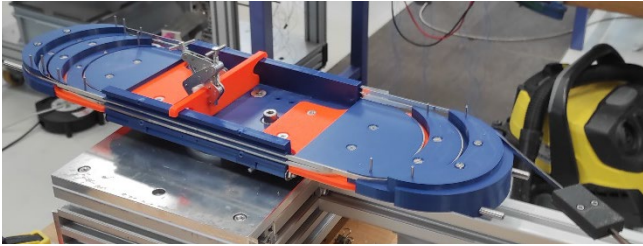

Racetrack winding – cosine θ geometry with elliptical ends

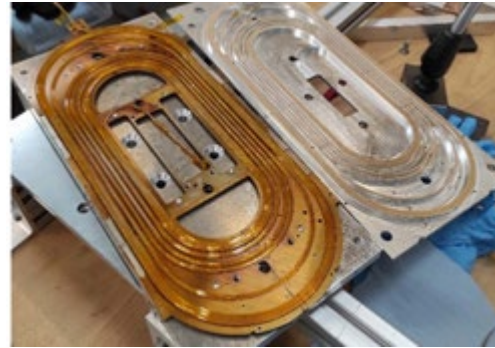

Race-track coil

HTS sub-scale RS1

Magnet Assembly and Tests at PSI (LN₂) and CERN - 2026 (4.5 K and 20 K)

HTS sub-scale RS2

Conceptual Design Finalization, Coil Manufacturing Development, and LN₂ Testing

REBCO Cable Develop.

Short-Length Sample Production and LN₂ Testing

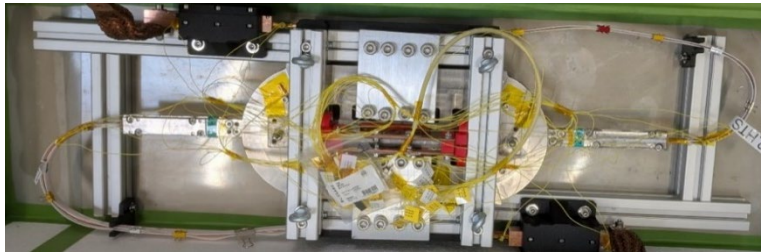

Double Racetrack of HTS (ReBCO) insulated (soldered) tape-stack cable tested at PSI

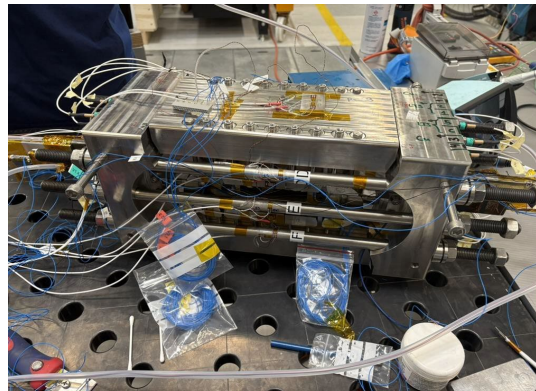

REBCO Subscale magnet 1

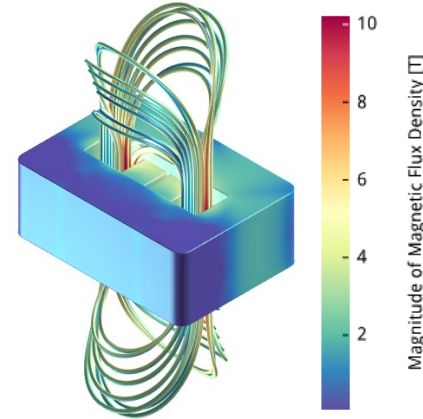
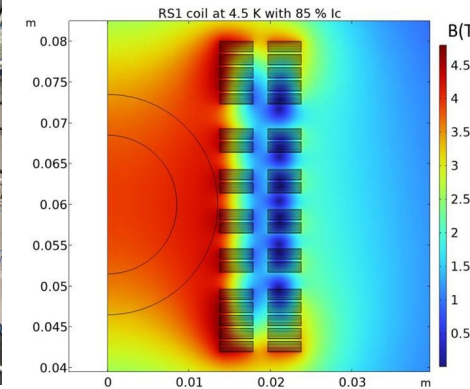

REBCO Subscale magnet 2 optimized coil geometry

Stress management of the Lorentz forces by the geometry

Assess: engineering current density, AC losses, field quality
Synergies for PSI magnets: coil fabrication, stress management, fast ramping operation

HTS magnet for energy saving : FCCee-HTS4 project (CHART/CERN/PSI)



Replace all arc normal conducting quadrupoles and sextupoles of the FCC-ee arcs (89 MW), with superconducting ones using HTS technology



Design, fabricate and test a cryocooled HTS combined function (quadrupole & sextupole) working at 40 K for energy saving in FCC-ee short straight section magnets

- *HTS technology : reduce the consumption by 20 % i.e. 2.9 TWh*
- *Nested geometry : only one type of neighbouring dipoles → increase the packing factor and the luminosity*
- *Sister CHART project : FCC-ee cryogenic power converter (CPES) developed with ETHZ*

Two prototyping geometries : Canted Cosine Theta (CERN) and Cosine Theta (PSI)

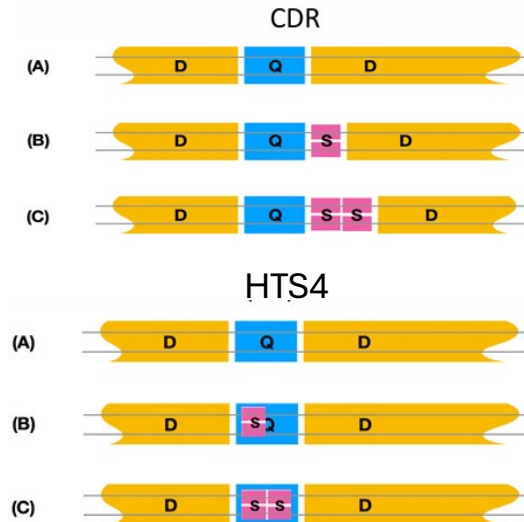

PSI sextupole (cosine Theta) prototype fabricated and tested



Sextupoles made of 6 racetrack HTS coils (coated HTS tapes at PSI)

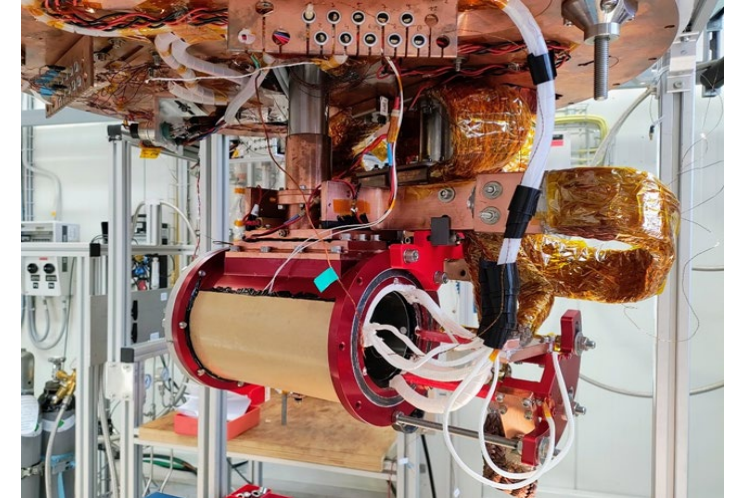

Cryogenic test of the sextupole at PSI

M. Koratzinos (CERN)

Perspectives 2026 : Fabrication of a full nested magnet and test between 30-70 K

Synergies : conduction cooled HTS magnet construction, field quality, compactness, and reduced power consumption

NI HTS technology for a high field solenoid of the PSI Positron Production (P³) Experiment

P3 final assembly, cryogenic tests up to 1 kA (~10 T, 21 K), and installation in the SwissFEL beam line

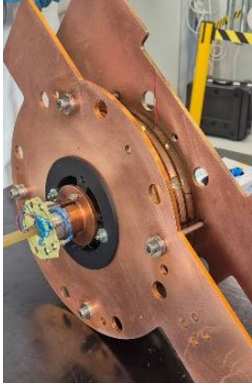

5x 12 mm wide
Non insulated HTS coils

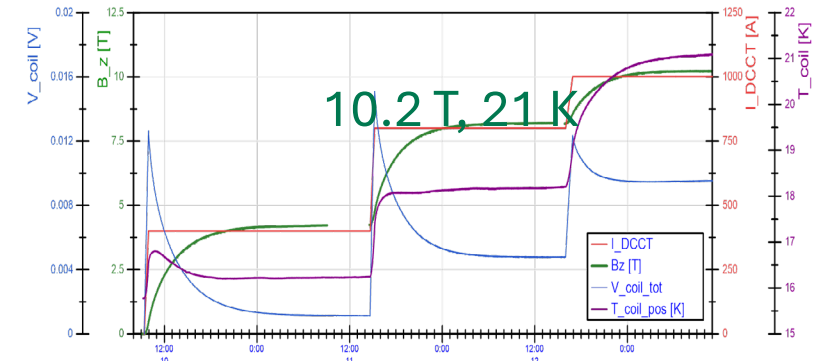
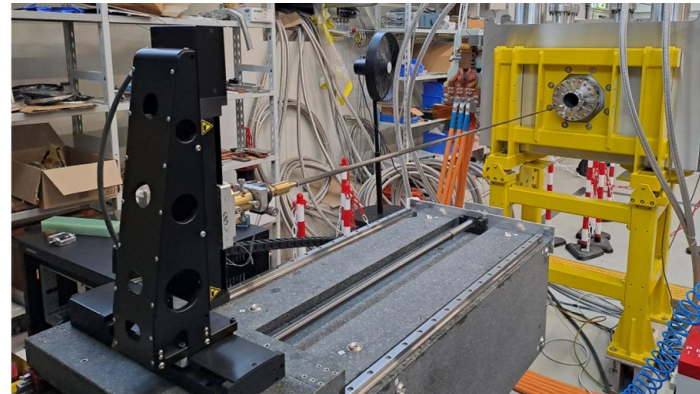
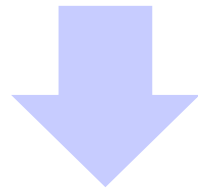
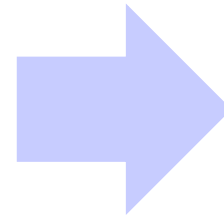
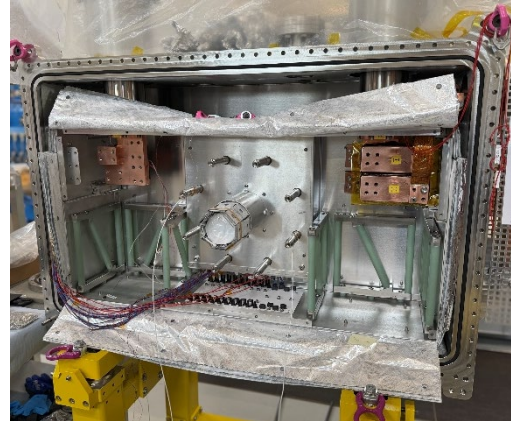
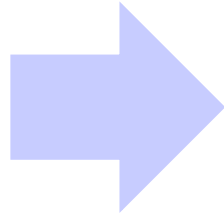

Direct application : HTS solenoid will be installed into an accelerator beam line (2026) !

Split HTS Solenoid for Neutron Scattering experiment in SINQ (CHART-PSI)

18 T solenoid

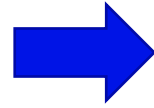

17 T @10 K 1700 A ,10 mm split

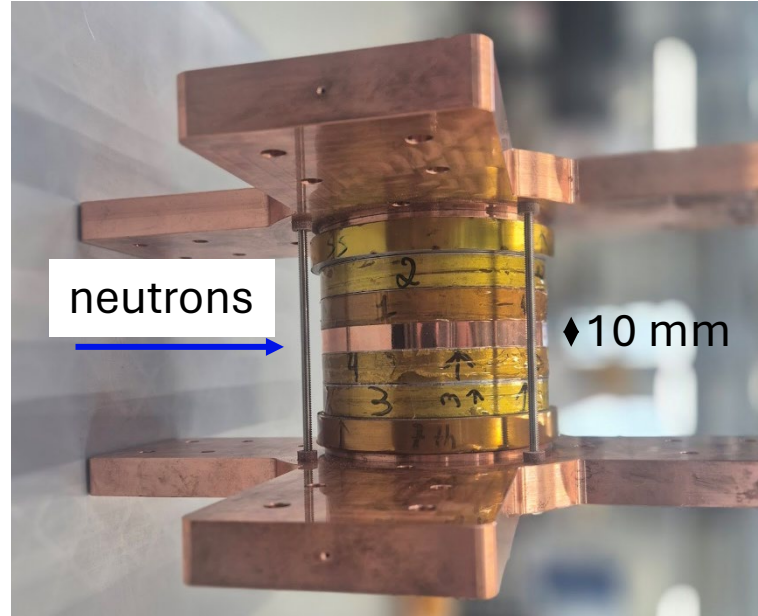
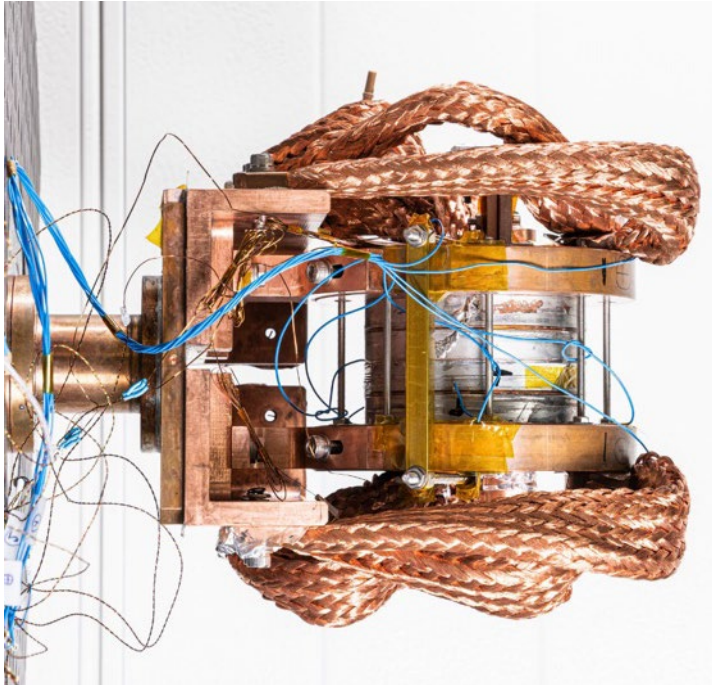

LN2 test

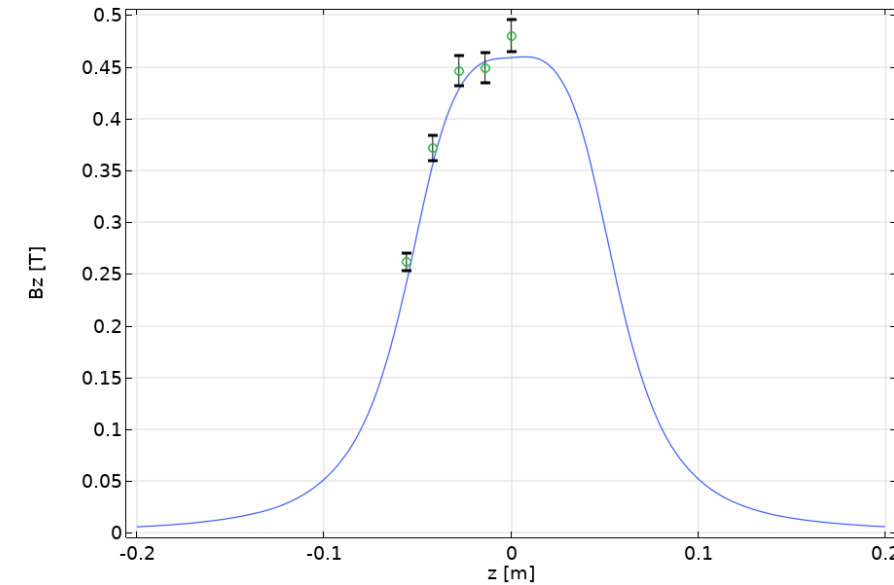

- Split coils with NI HTS double tapes;
- Operating temperature: ~12 K;
- Cooling provided by a two stages GM cryocooler;
- Current leads cooled with liquid nitrogen.

- 2025: Stack assembled
- 2025: Initial LN2 tests
- 2026: Integration in dedicated cryostat

HTS solenoid for the PSI Muon EDM experiment in the $\mu E1$ beam line (HIPA)-2030?



<https://www.psi.ch/en/ltp/muedm-experiment>

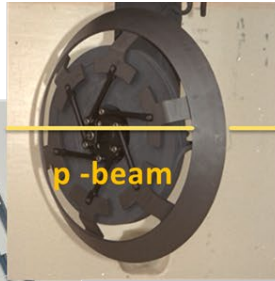

μ -beam:
 • $10^8 \mu^+ / s$
 • Bunch width 3.9 ns

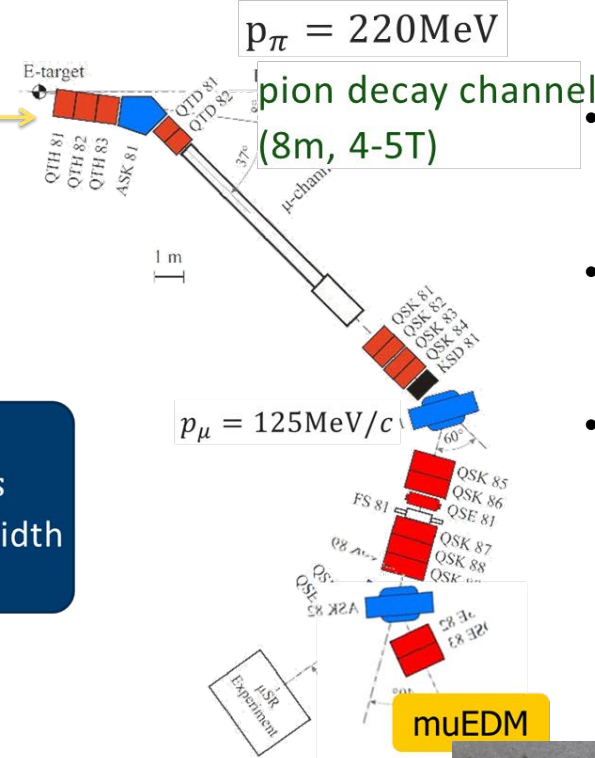

- Design of a superconducting solenoid for measurement of muons Electric Dipole Moment (μ EDM)
- Development of a zero-field superconducting injection channel into solenoid \rightarrow use of HTS bulk/tape (2024)
- High peak field (5 T), large aperture (0.5 m) solenoid for magnetic storage muons trap (highly uniform magnetic field required to control muon spin dynamics)



YBCO tape Helix

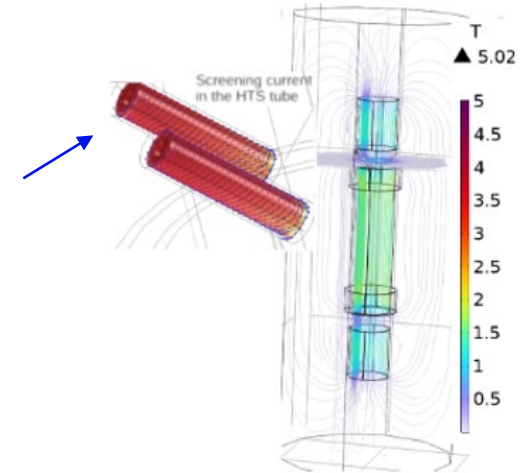

Higher field \rightarrow better signal-to-noise \rightarrow improved EDM sensitivity
 HTS : working above 20 K possible, cost efficiency

Design of a 5T HTS solenoid from mid-2026 to mid-2030: Ph.D. student with SNFS grant

Radiation hardness study (SMILE –pole1)



70 magnets with Mineral Insulated Cables (MIC) (highly radiative environment)

Replacement of high-energy-consumption magnets with LTS and HTS magnets

Cost-effectiveness & performance including *thermal stability and radiation effects*



AHL with MIC coils

Typical MIC cross-section

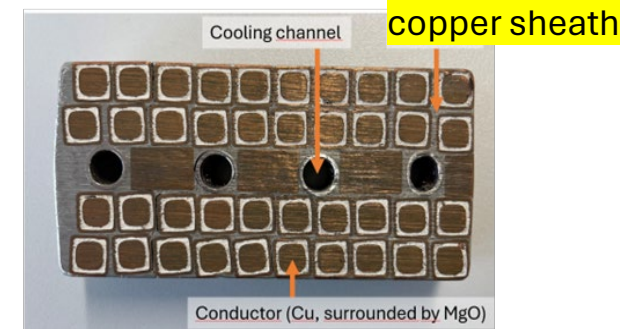

Program 2025-2029

- **Modeling** of the radiation effects on HTS tapes & coils
- **Test of HTS samples** in PSI facilities (Gantry 1, PIF, NIS...)
- **Produce an HTS coil without organic insulation**
- **Build an HTS magnet demonstrator** to test the changes in superconducting properties under radiation exposure online in **HIPA** → 2026
- **Validation numerical model** on experimental data on HTS irradiated samples and coils
- **Pilot Magnet design and assembly** to be installed in a PSI beam line?
Activity linked with EU HTS4SRI project

Irradiation (n, p) of HTS tapes and coils



Proton Irradiation Facility

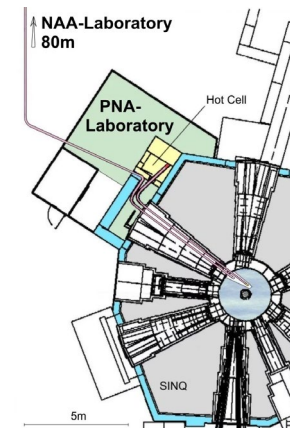

Irradiation effect on HTS magnet demonstrator



Experiment set-up:

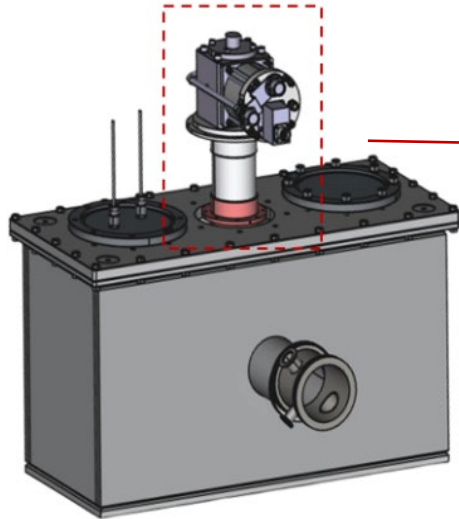

Aluminum Cryostat

The cryostat features inner and outer **aluminum** shields

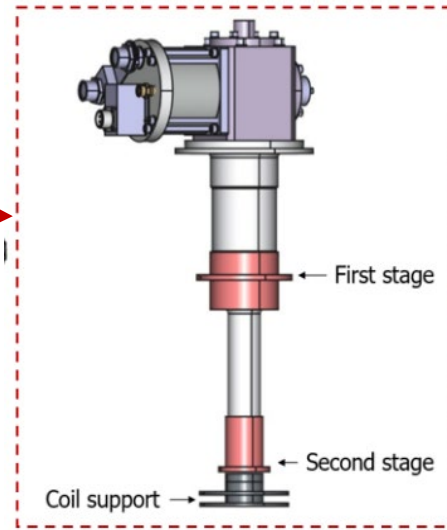

Cryocooler head

The cooling system is based on a RDK-415D2 cryocooler, which provides about 1.5 W at 4 K

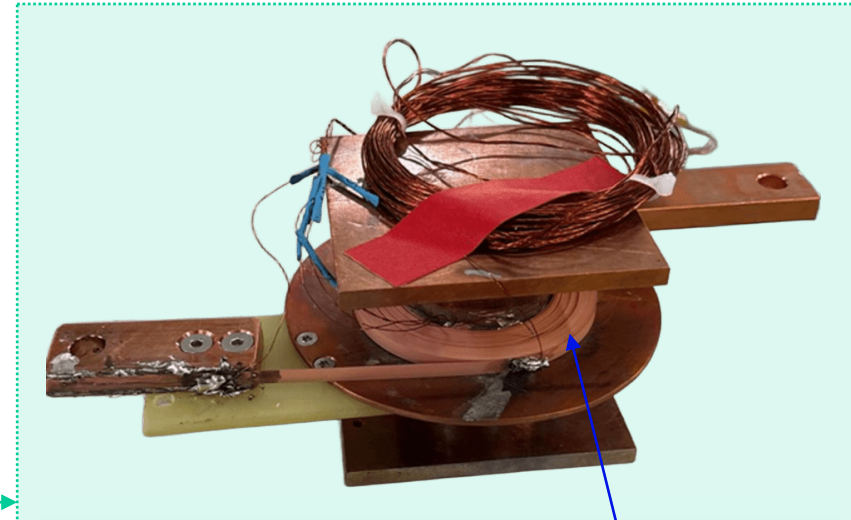

HTS Coil on a copper support

The HTS coil consists of **150 turns of 4 mm Faraday Factory tape**, in dry-wound configuration.

Dose rate: $\sim 5 \times 10^{-4}$ Gy/s

Neutron fluence after 4000 h: 10^{18} n/m²

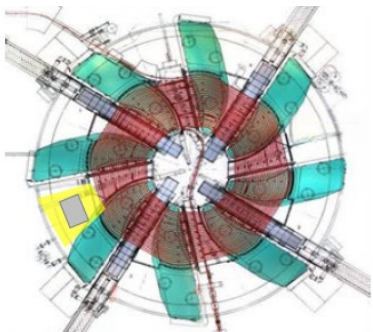

→ The final demonstrator will be installed in the cryostat near the cyclotron and operated between 10 K and 40 K to monitor its critical parameters.

→ Neutron flux will be measured using activation foils and beam loss monitors to correlate radiation exposure with coil performance and assess its long-term reliability.

Perspectives 2026 : Installation of the HTS demonstrator close to the PSI ring. Monitoring of the irradiation effect on superconducting properties. Information for the possible replacement of the AHC magnet in the PSI ring

- The increasing energy demand of more powerful accelerators requires a more efficient and sustainable approach to magnet technologies.
- PSI benefits from a strong ecosystem of ambitious strategic projects, of an FCC-oriented R&D program (CHART) and innovative industrial environment, creating a unique opportunity to drive the energy transition through HTS magnet technology.
- SMILE and HTS4SRI are developing key technological building blocks for cryocooled HTS magnets tailored to the needs of current and future PSI large research facilities.
- The future use of HTS magnets—combining high performance, energy savings, reduced operational costs, and lower environmental impact—is progressively gaining momentum.



Join us in shaping the future of efficient and sustainable HTS magnet technologies



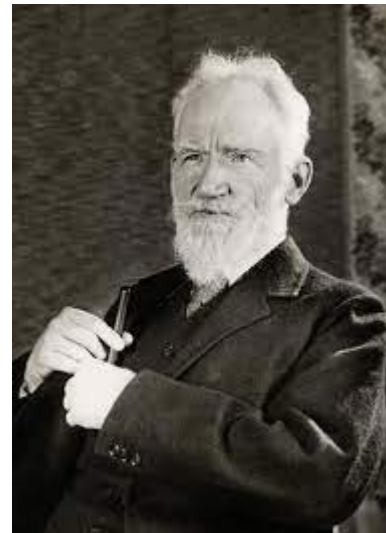
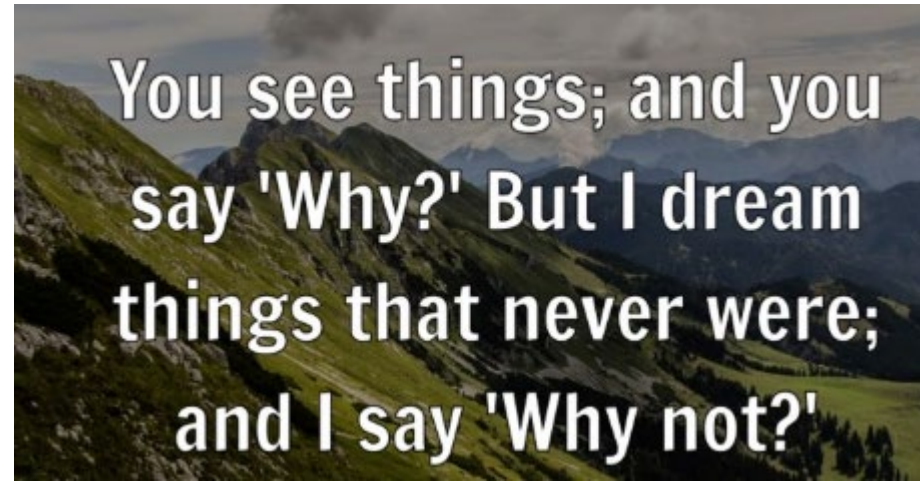

George Bernard Shaw (1856–1950)
Irish playwright, critic, dramatist and polemist
Nobel Prize in Literature in 1925

**Thank you
for your attention**