

# Realization of High-Intensity Beams with Smaller Emittance Without a Transverse Feedback System

*Yoshihiro Shobuda* (J-PARC/JAEA),

Pranab Kumar Saha, Ippei Yamada (J-PARC/JAEA)

Takeshi Toyama (J-PARC/KEK)

Nobuyuki Yoshimura (Toshiba)

## ◆ Outline

- Introduction
- J-PARC RCS kicker (merits and demerits)
- Beam instabilities observed at the RCS (discrepancy from classical theory)
- Theoretical explanation (role of space charge effects)
- Kicker impedance suppression (how to retain the merit of the kicker)
- Performance of the impedance measure (consistent with theory)
- Summary



# □ RCS kicker impedance is the main source of beam instability

- Kicker impedance

- about 10 times higher than the SNS kickers'.

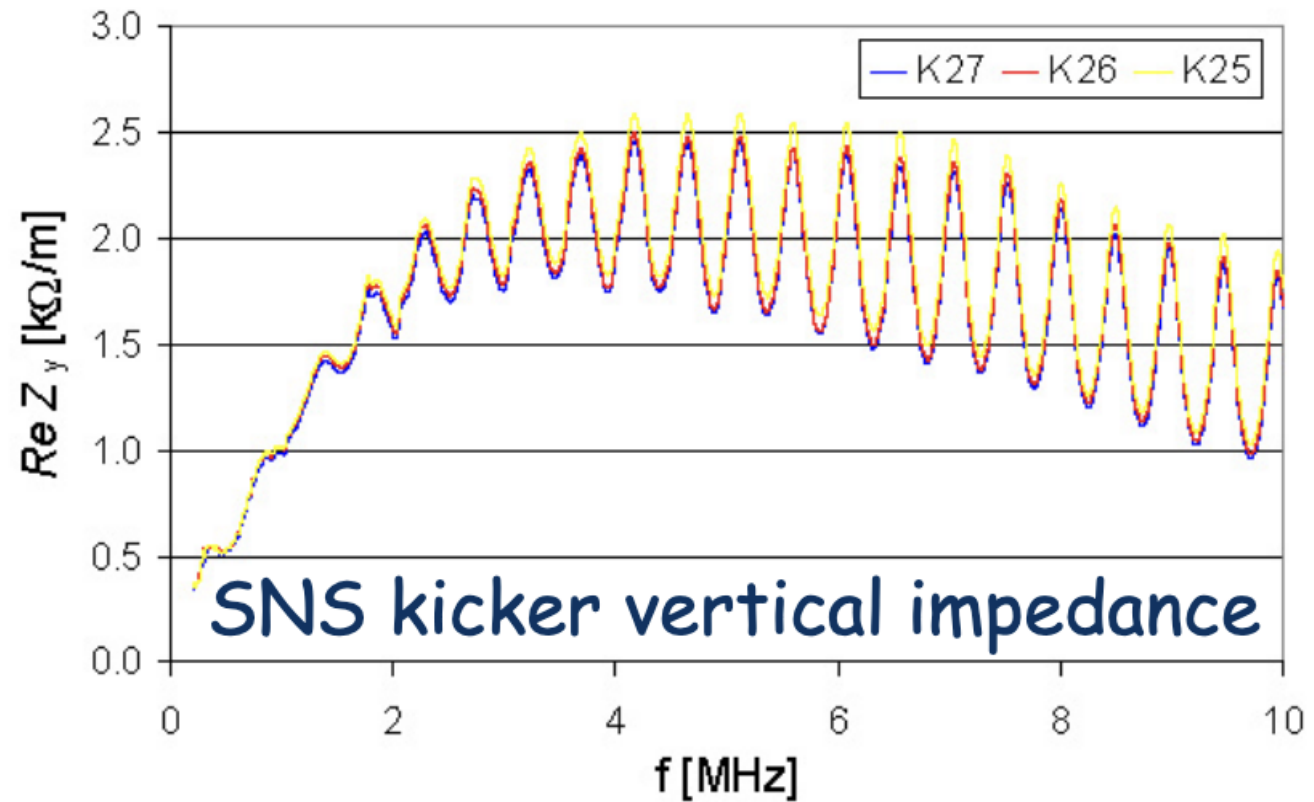
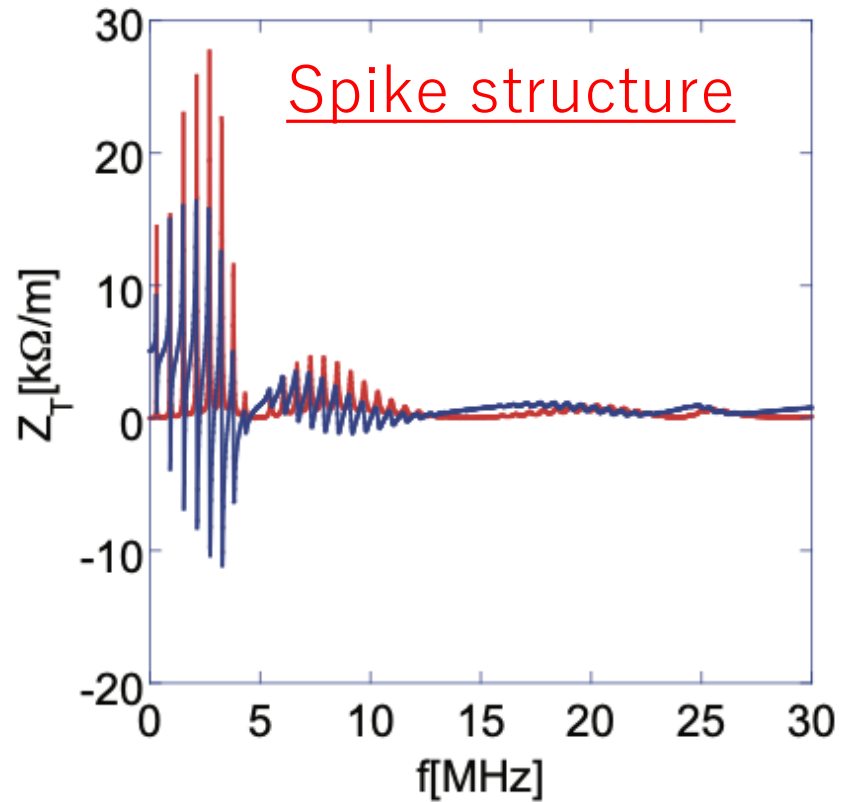

- Nevertheless,
  - eight kickers were installed.

## ➤ RCS kicker has merits

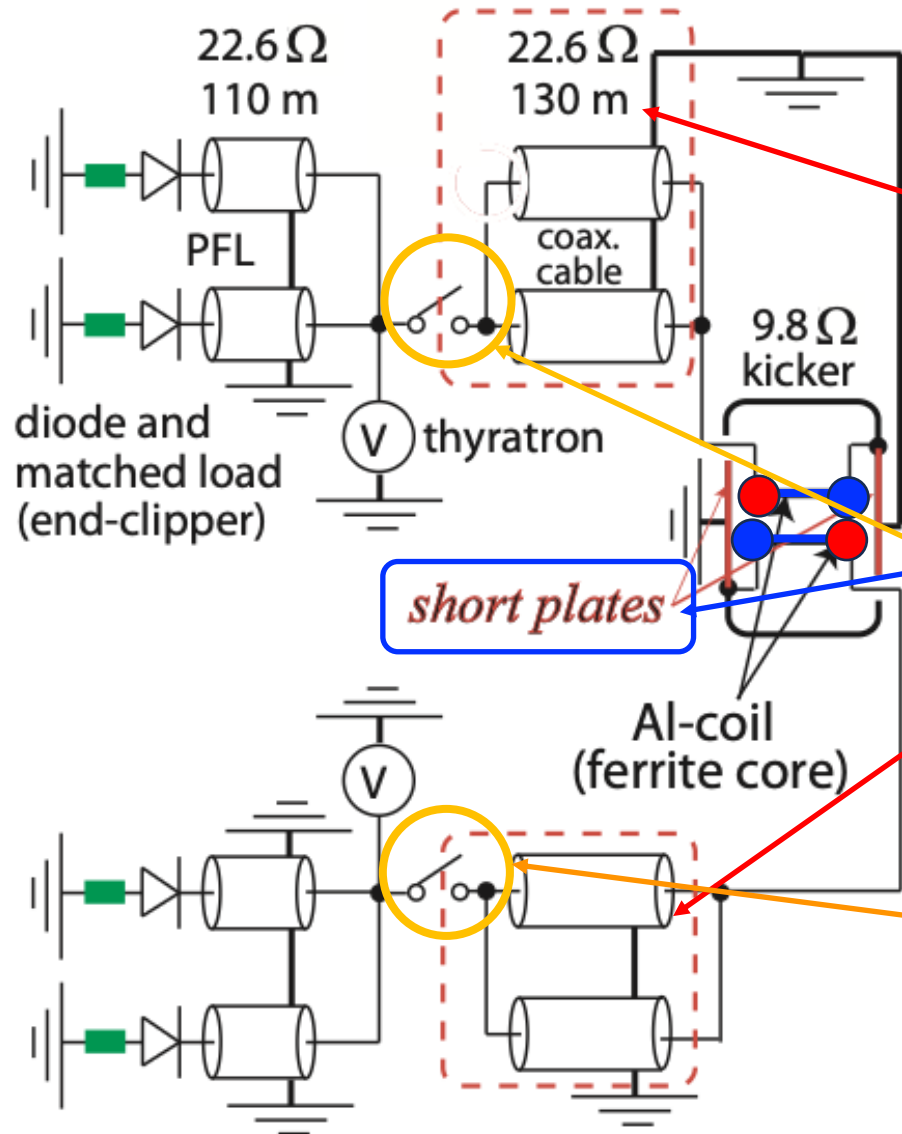

- Kicker is a transmission-line type with **two** ferrites and coils.
- Kicker has four terminals:
  - two connect to Power Supply
  - through **130-m coaxial cables**
  - two, **grounded**
- **Shorted plates save power**, by doubling excitation current for beam extractions.
- Structure **increases** beam **impedance**, during acceleration.
- because beam induces current on kicker coil,
- trapped in 130-m cables with **open** ends.

(0.76-MW beam)

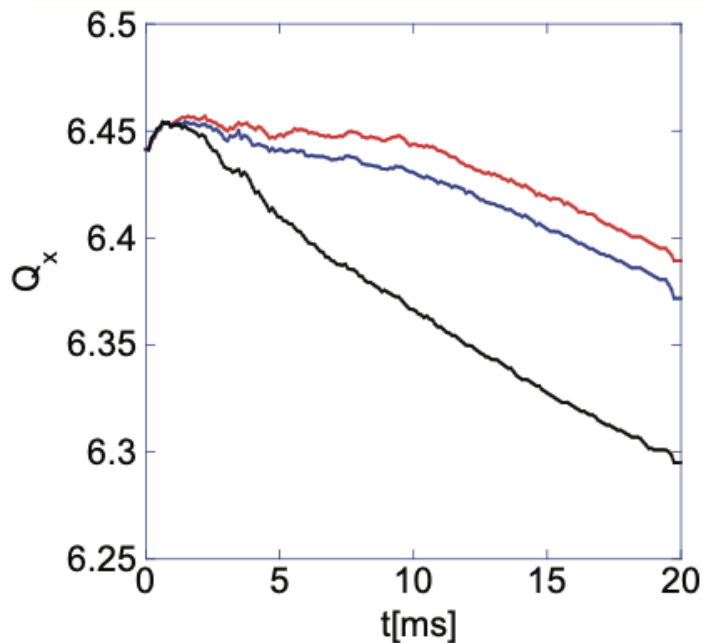
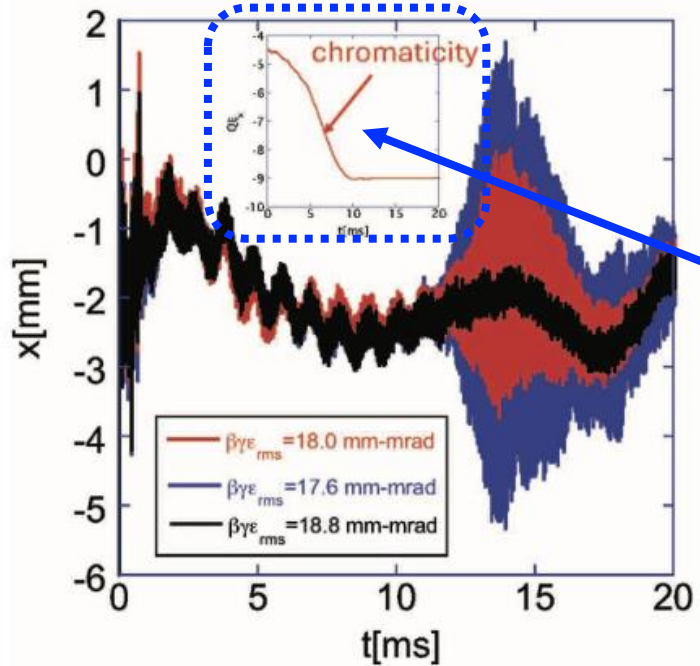

➤ Beam instabilities observed at RCS  
(discrepancy from classical theory)

□ Tune dependence

- following tune trackings in lower panel.
- Sextupole magnet, **turned off** after **10 ms** at higher energy.

- Beam **instability**, observed at **higher energy**
  - despite under **natural chromaticity**.

- Tune dependence exists, suggesting
  - **resonances** in **kicker impedance** drive beam instability.

## Classical theory vs. measurements (1-MW)

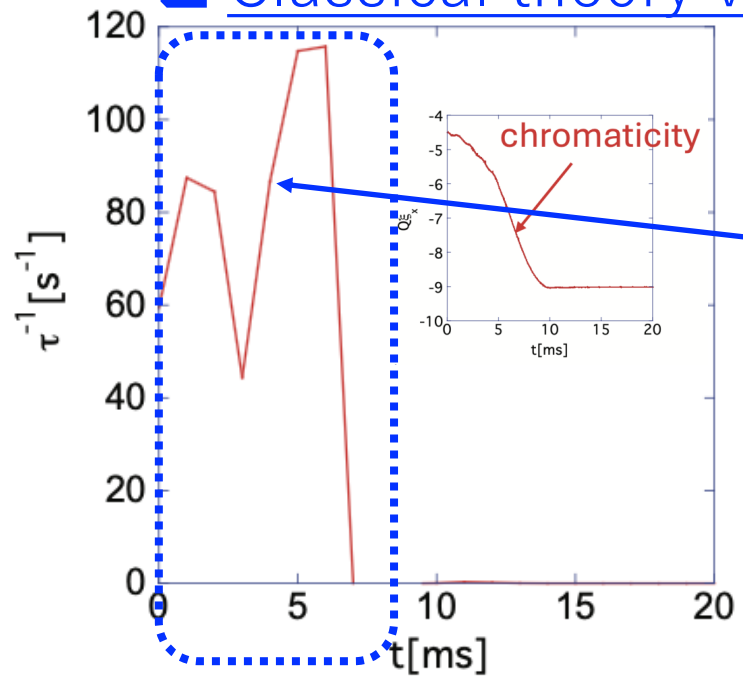

- Sextupole magnet, turned off after 10 ms.
- Theory **neglects** space charge.

- ❖ Instability, excited at **low energies**: Theory (Sacherer's **formula**).
- ❖ Instability, observed at **higher energies**: **Measurements**.

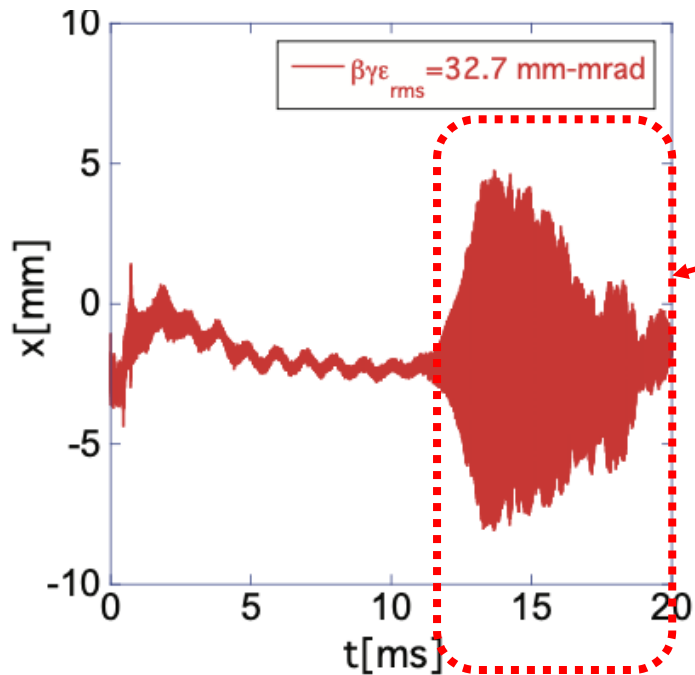

- A discrepancy exists, suggesting space charge affects **beam instability**.

## □ Emittance dependence (0.76 MW beam) for different sextupole settings

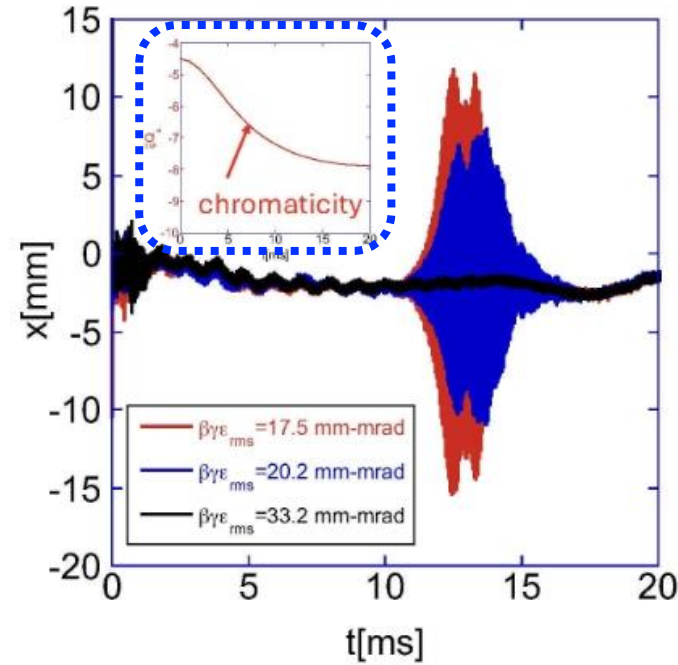
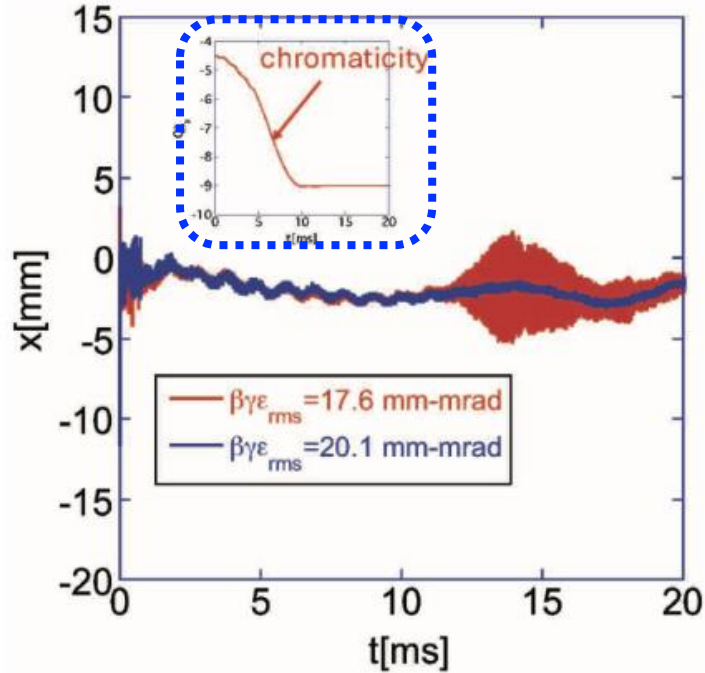

- **Right panel** : Sextupole magnet corrects half of chromaticity at injection using DC power supply.
- **Left panel**: Sextupole magnet turned off after 10 ms.

### ○ Emittance Variation:

- **Black/Blue** : Results for *larger emittance*.
- **Red**: Results for *smaller emittance*.

### ● Key Observation:

Beams with *smaller* emittance excite instability.

## □ Bunching factor dependence (0.76 MW beam)

○  $B_f$ , average current / peak current

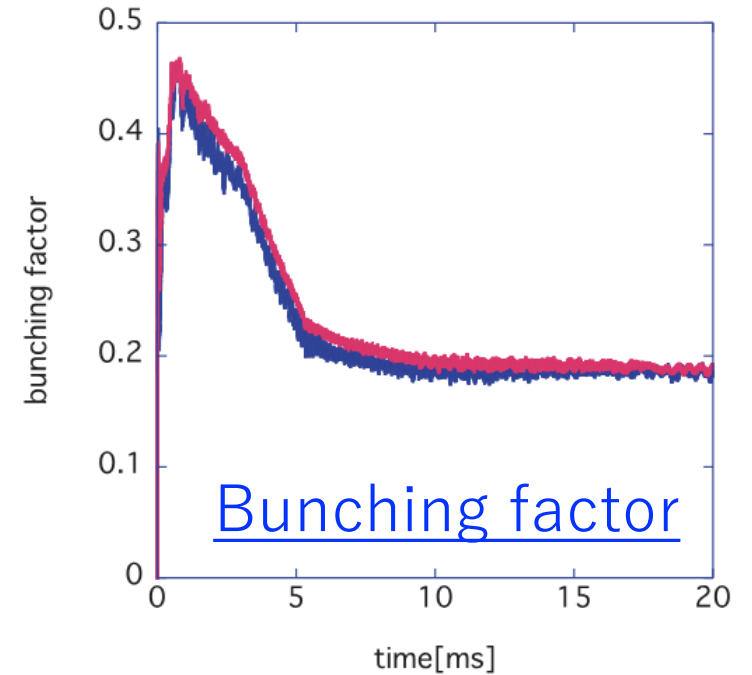
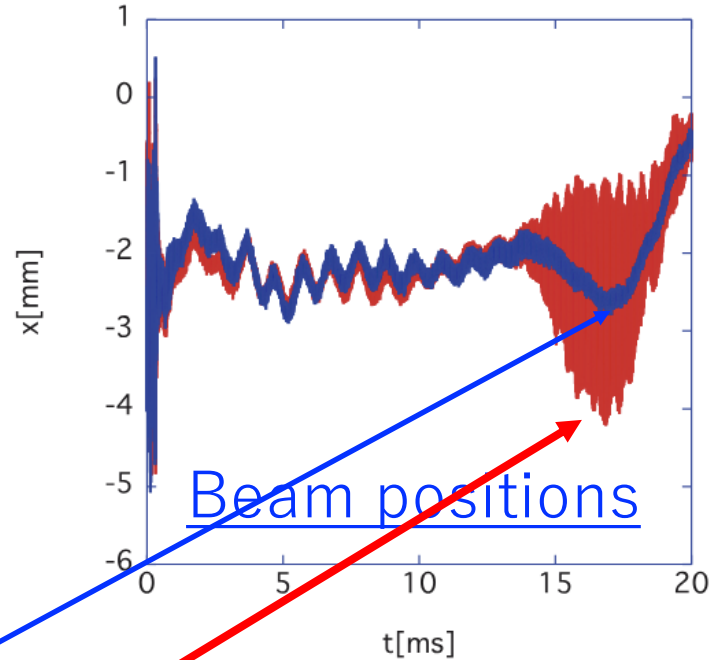

- **Blue:** results for *higher* peak current.
- **Red:** results for *lower* peak current.

- Beam is not always stable for lower peak current.
- This contradicts the prediction of classical theory, neglecting space charge effects.

➤ Theoretical explanation (role of space charge effects)

- Beam growth rate is evaluated by solving the dispersion relation for  $\nu$ .

$$\sum_{p=-\infty}^{\infty} \frac{je^2 N_b M \beta_s^2 \sum_{i=1}^{N_{kicker}} \beta_x^{(i)} Z_T^{(i)} (\omega_0(\nu + \mu + pM))}{8\pi^2 J_{x0} p_s R \left( m \frac{d\nu_L}{dJ_x} + \frac{d\nu_x}{dJ_x} \right)}$$

$$\times \left| J_m \left[ (\nu + \mu + pM) - \frac{Q_x \xi_x}{\eta} \right] \sqrt{\frac{2\omega_0 J_{L0} |\eta|}{c p_s \beta_s v_{s0}}} \right|^2$$

$$\approx \frac{1}{\left[ 1 + \frac{(\nu - m\nu_{L0} - \nu_{X0}) e^{\frac{(\nu - m\nu_{L0} - \nu_{X0})}{\left( m \frac{d\nu_L}{dJ_x} + \frac{d\nu_x}{dJ_x} \right) J_{x0}}} \Gamma \left[ 0, -\frac{(\nu - m\nu_{L0} - \nu_{X0})}{\left( m \frac{d\nu_L}{dJ_x} + \frac{d\nu_x}{dJ_x} \right) J_{x0}} \right]}{\left( m \frac{d\nu_L}{dJ_x} + \frac{d\nu_x}{dJ_x} \right) J_{x0}} \right]}$$

- The original formula in (Shobuda *et al*, PTEP, 013G01, 2017) is extended to include  $\beta_x^{(i)}$  dependence for  $i$ -th kicker ( $i$  runs 1 to 8).

- $B_f$ -dependence of beam growth rate @ 15 ms.

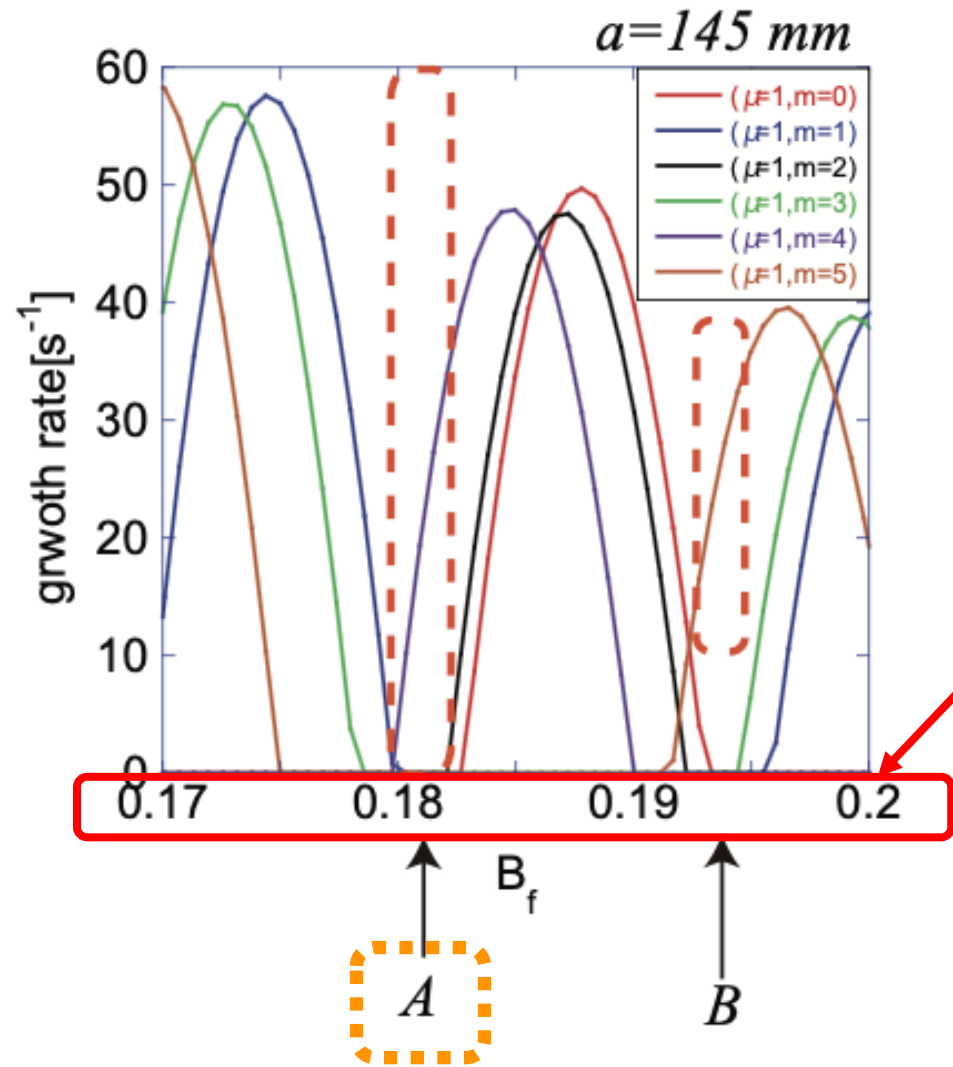

- Beam growth rate **critically** depends on  $B_f$ .
- Around regions A and B, **beam growth rate becomes higher** as  $B_f$  gets **larger**.

### Measurements (0.76 MW)

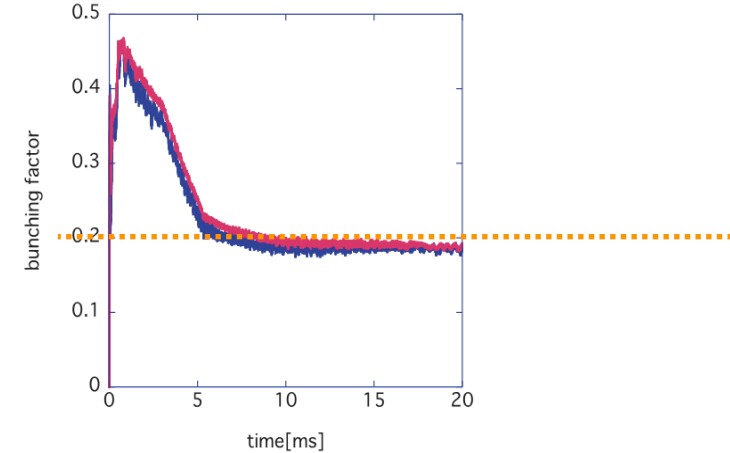
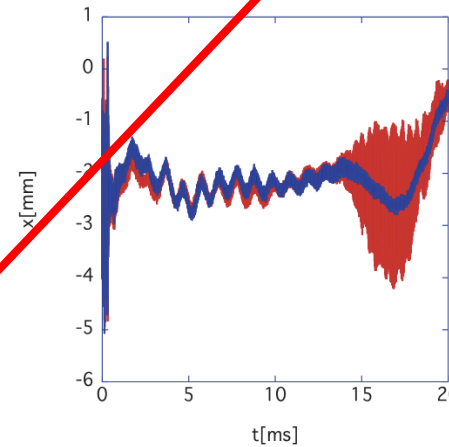

- Theoretically, **region A** corresponds to measured case.

- Theory predicts **increasing the peak current can stabilize the beam**, due to space charge effects.

□ Tune-dependence of beam growth rate (Theory).

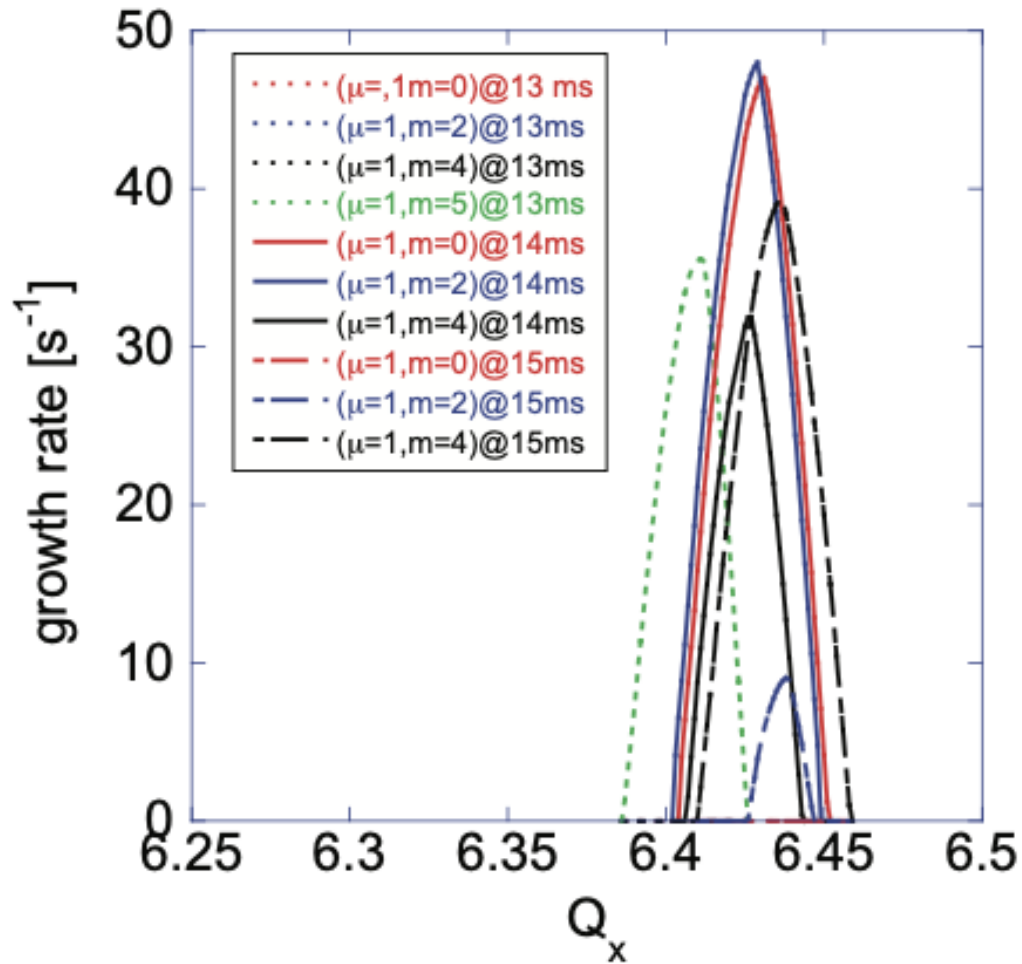

- Instability begins at 13 ms if tune stays around 6.4–6.45.

Measurements (0.76 MW beam)

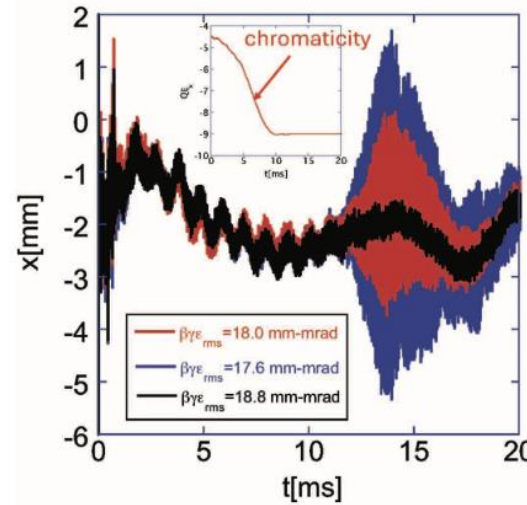

- Stable: black
- Unstable: red, blue

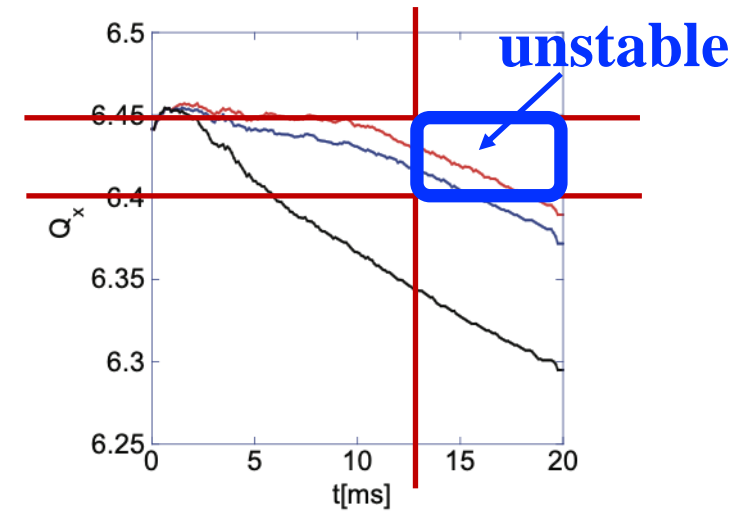

- Measurements align with theoretical prediction.

- Kicker impedance drives beam instability at high energy, due to reduction of space-charge effects, with tune crossing around 6.4-6.45

# Chromaticity effects

Beam growth rate @14 ms

- **Right:** chromaticity is -7.5.
- **Left:** chromaticity is -9.

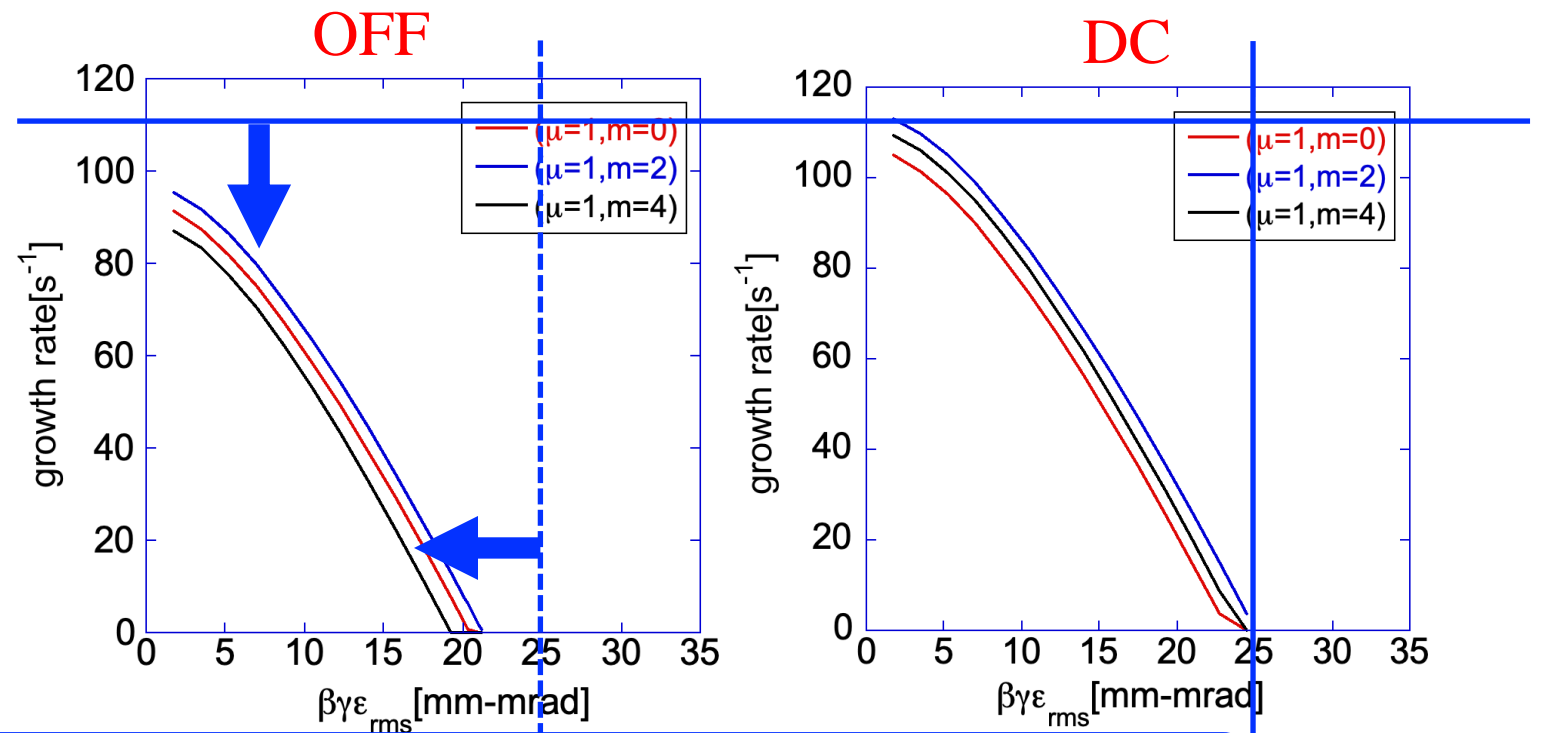

❖ Theory: **increase in chromaticity** in negative direction realizes **smaller** emittance beams.

○ Measurements (0.76 MW) for different sextupole settings:

Right: chromaticity, partially corrected.

Left : chromaticity, uncorrected.

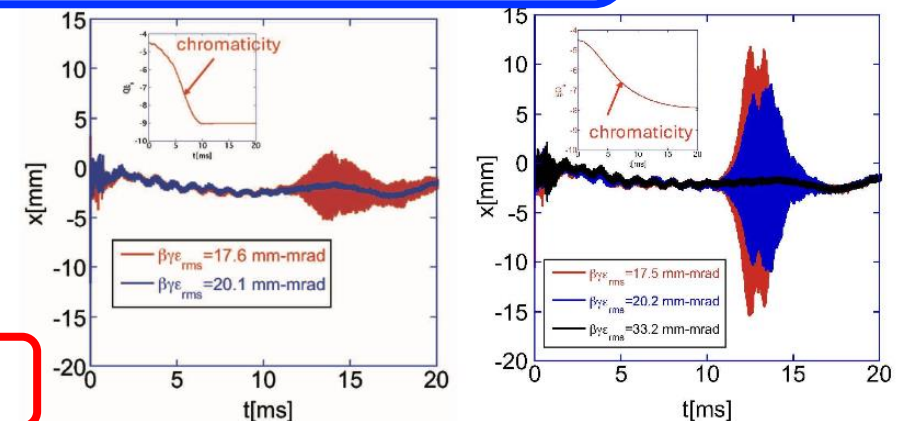

❖ Blue demonstrates **effectiveness** of measure.

## □ $\beta\gamma\epsilon_{rms}$ -dependence for different setupole settings

- **Right** : Chromaticity, half-corrected using **DC** power supply.
- **Left** : Sextupole, switched **OFF** after 10 ms.

### ○ Emittance:

- **Red** : *17.6 mm-mrad*
- **Blue** : *20. mm-mrad*
- **Black** : *33. mm-mrad*

□ Black, stabilized thanks to the largest emittance.

□ 20 mm·mrad beam, stabilized simply by turning off sextupole.

□ Smallest emittance beams excite beam instability, even when sextupole is turned off.

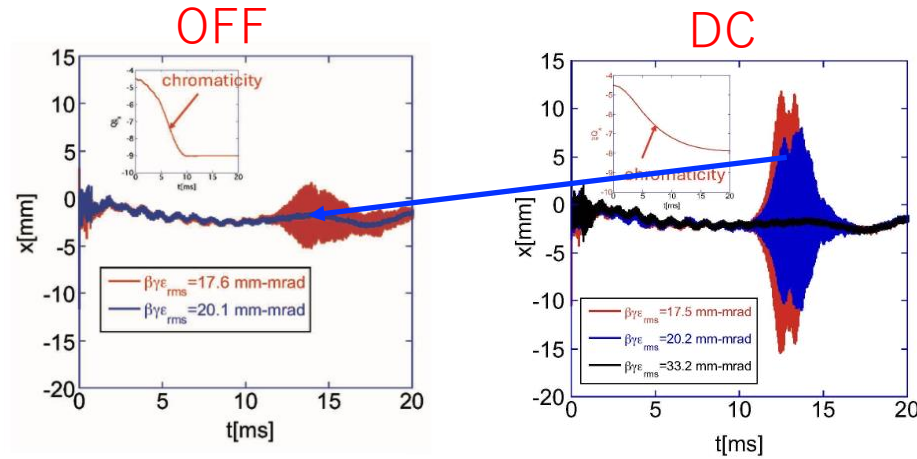

Measurements (0.76 MW)

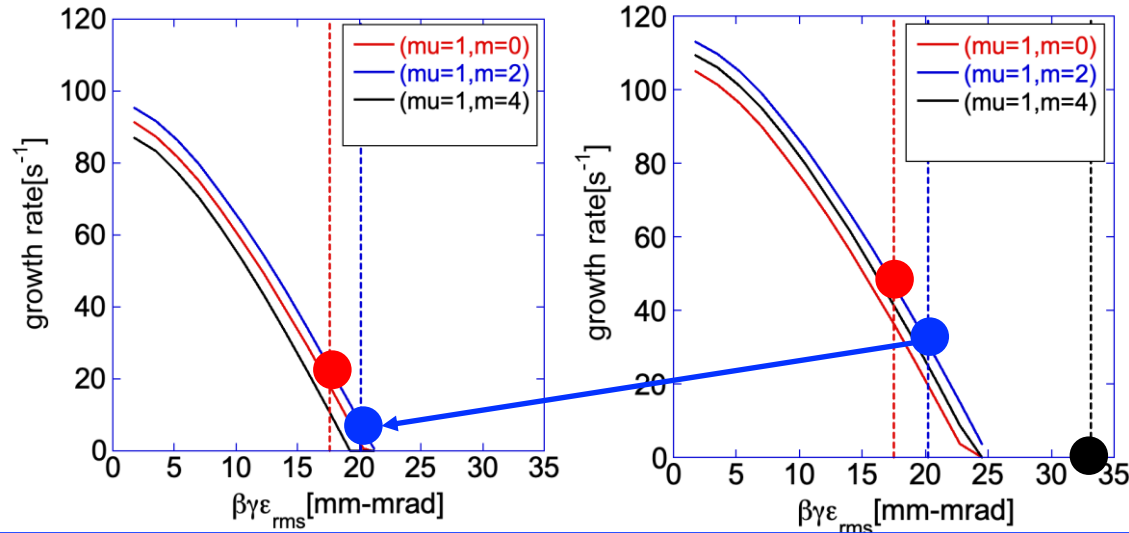

Beam growth rate @14 ms

❖ Theory well describes measurements.

❖ Emittance dependence suggests

indirect space-charge effects suppress beam instability.

## □ Indirect space charge effects for different sextupole settings

**Solid Line:**  
Chamber radius,  
145 mm.

**Dashed Line:**  
Chamber radius,  
160 mm.

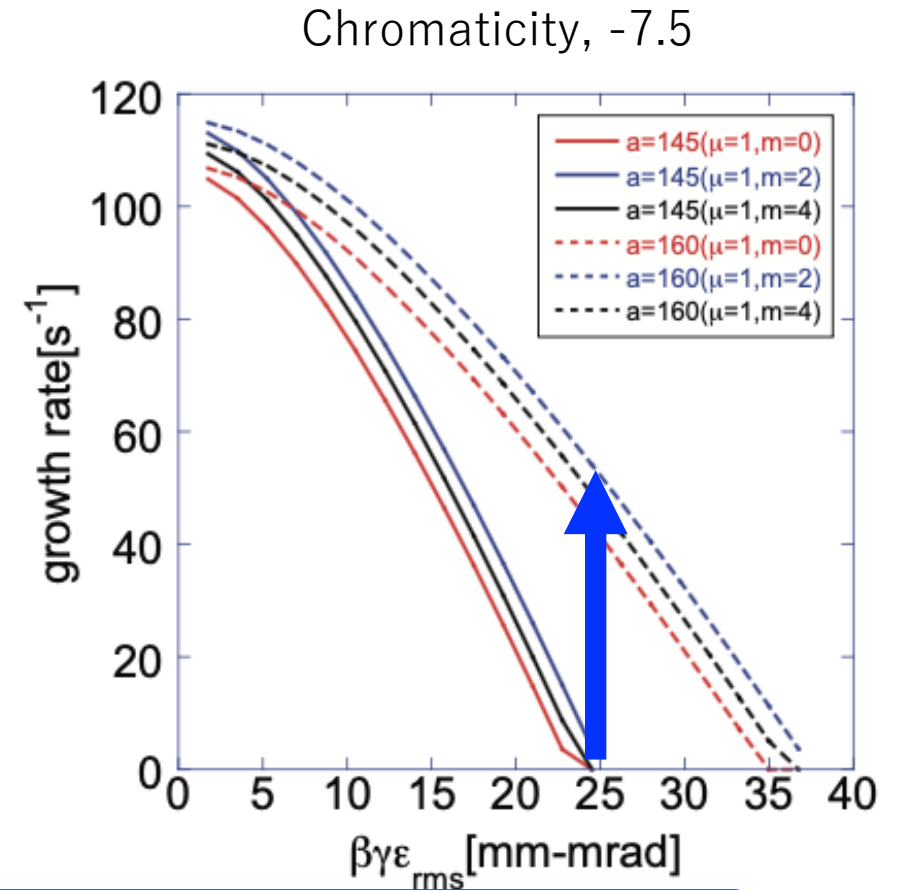
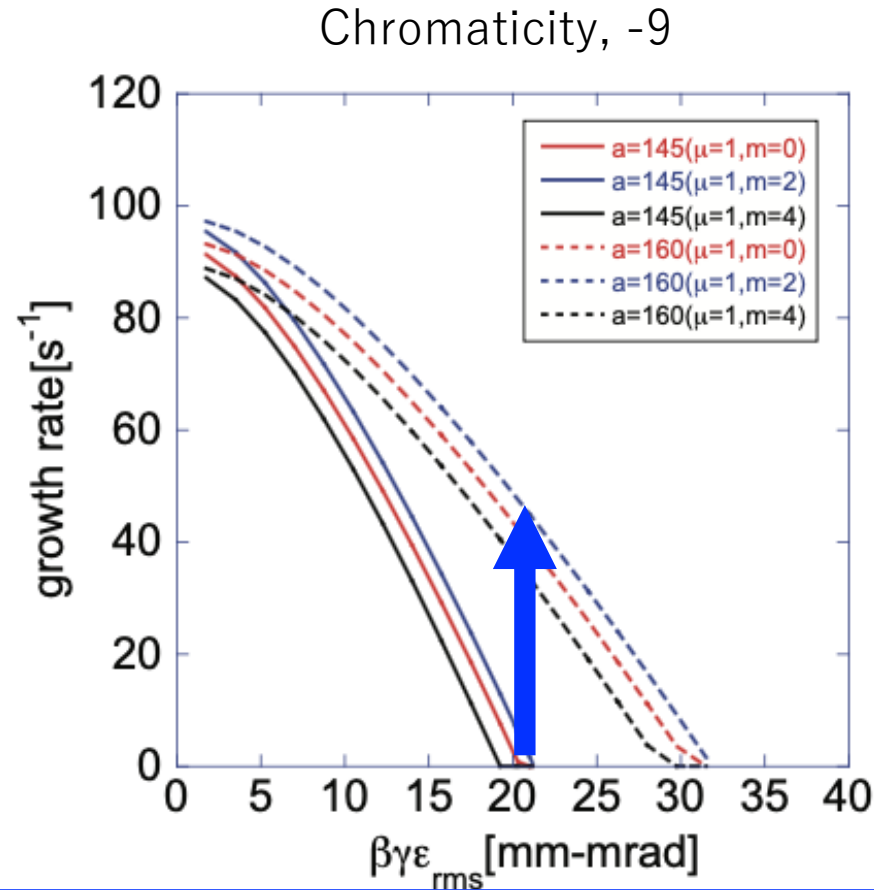

❖ Increasing chamber radius  $a$ , enhances beam growth rate.

○ Indirect space-charge effects are essential:

- stabilize large-emittance beams at low energy,
- destabilize small-emittance beams at high energy.

## □ Simulation supports (Saha *et al*, PRAB21, 024203, 2018)

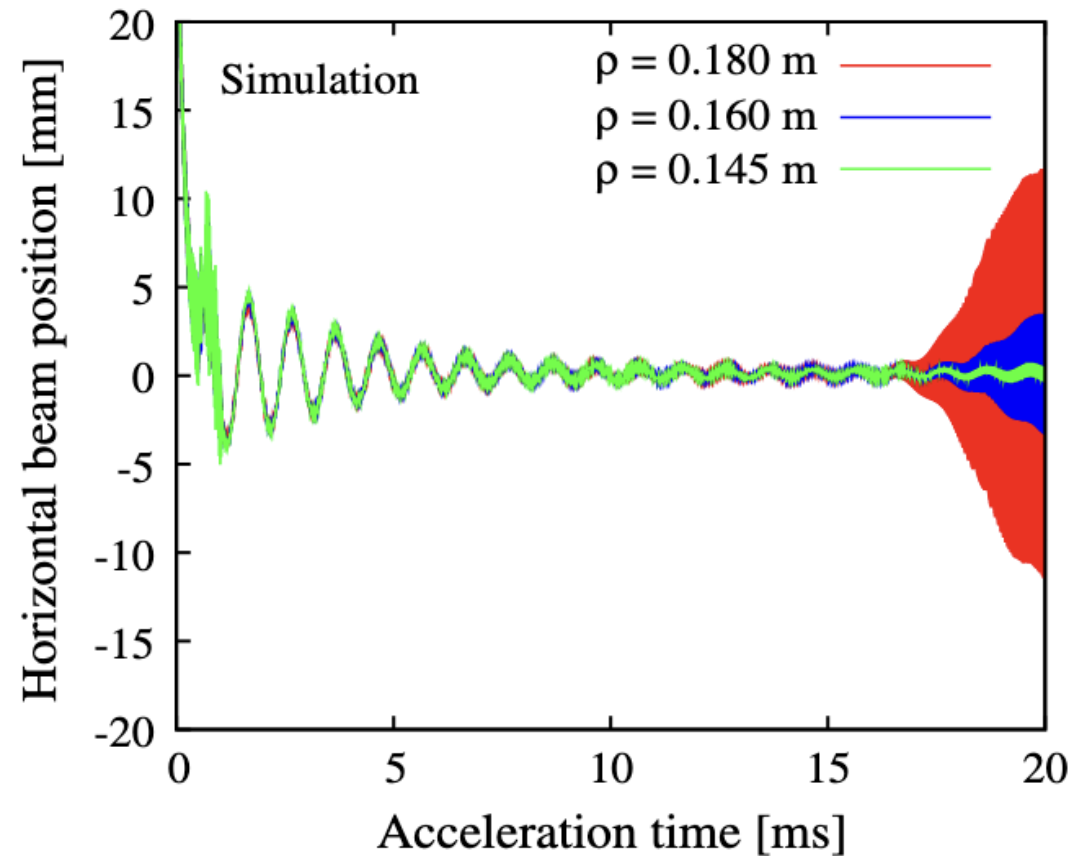

**Chamber Radius  
Parameter:  $\rho$**

- ❖ Theoretical predictions were supported by simulations with ORBIT (SNS).
- ❖ Increase in chamber radius  $\rho$  leads to enhancement of beam growth rate.

## □ Discrepancy with Alternative Theoretical Model

- Simulations differ from those of another theoretical model.
  - Burov model (PRAB22, 034202, 2019) that accounts for **direct space charge** predicts **stronger instabilities** than in the case where only wake fields are considered.
- Kicker impedance specific to RCS, might stabilize beams unexpectedly ?

□ A resolution [Yoshimura, Toyama, and Shobuda (PRAB22, 034202, 2025, selected as editors' suggestion)]

- Linear model of space-charge in the J-PARC MR under 3-GeV storage mode,
- with resistive-wall impedances,

highlights effects of chamber wall on beam instabilities.

- **The time dependence of the beam distribution is taken into account.**
- **Linear model is** justified, transverse beam size is much smaller than chamber radius.

□  $N_B$  dependence of amplitude growth (simulations)

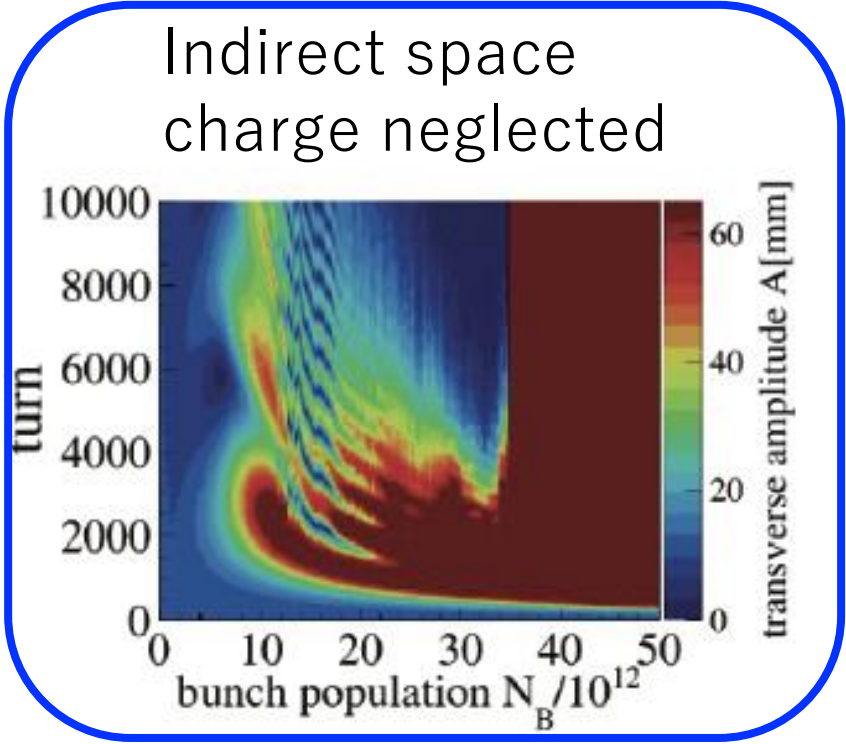
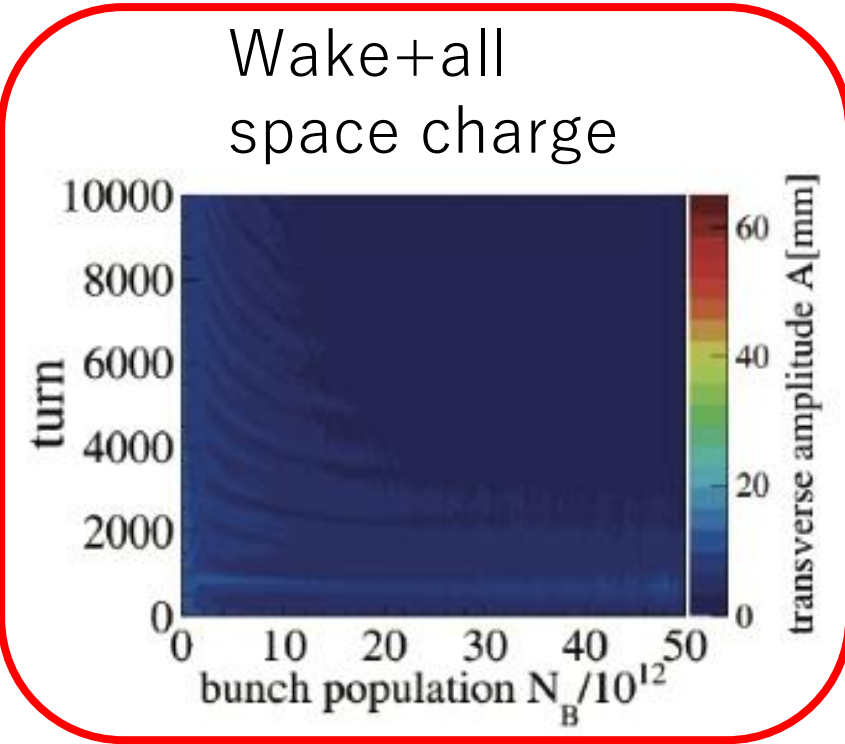
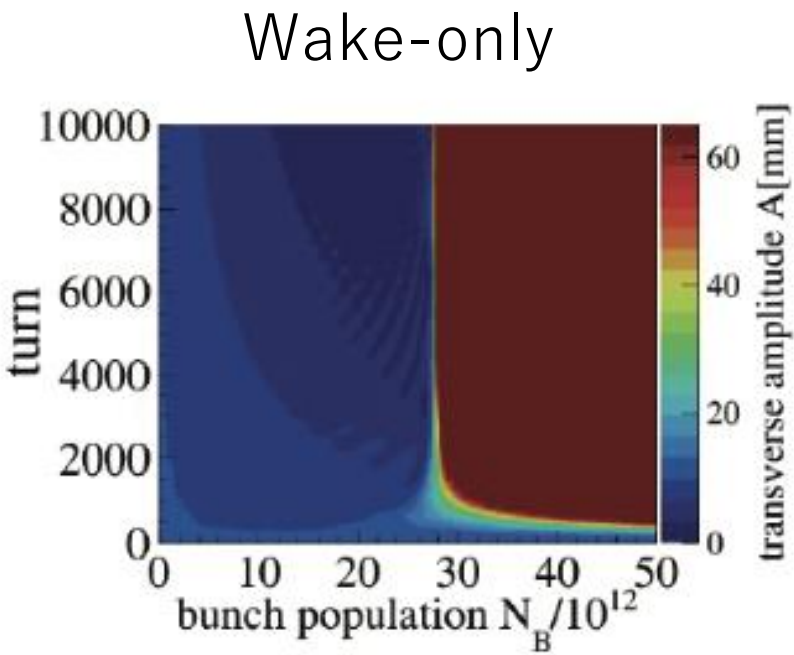

Blue: stable

Red :unstable

❖ The space charge effect is obvious

- Including *all* space charge effects *suppresses* beam growth rate (Middle) .
- Ignoring indirect space charge effects *increases* beam growth rate (Right).

❖ Two different predictions are reconciled.

## □ Mode excitation analysis along $N_B$ (simulations)

TMCI

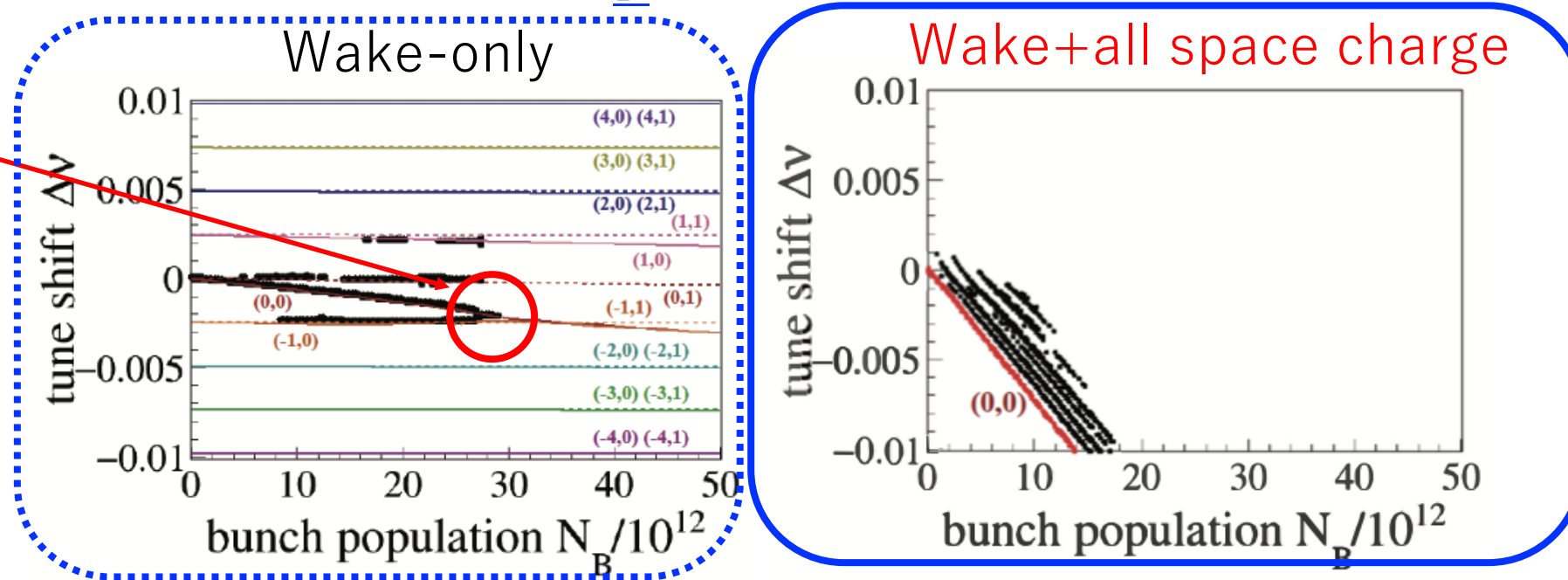

- Bullets show simulations (head-tail mode, radial mode).
  - In the wake-only case (left), **simulation reproduces** conventional theory by DELPHI (CERN).
  - Transverse mode coupling instability (**TMCI**) is source of beam instabilities.
- ❖ Right: **space-charge suppresses** negative head-tail, higher radial modes, **resolving TMCI**.
- ❖ This is mechanism, by which **space charges suppress beam instabilities**.

## □ Findings

- ❖ Indirect space charge effect suppresses beam instability  
for a wider range of impedances (including resistive-wall impedance),
  - ❖ which highlights
    - difficulty of accelerating high-intensity, low-emittance beams.
- ❖ Reducing kicker impedance is inevitable.

## ➤ Kicker impedance suppression

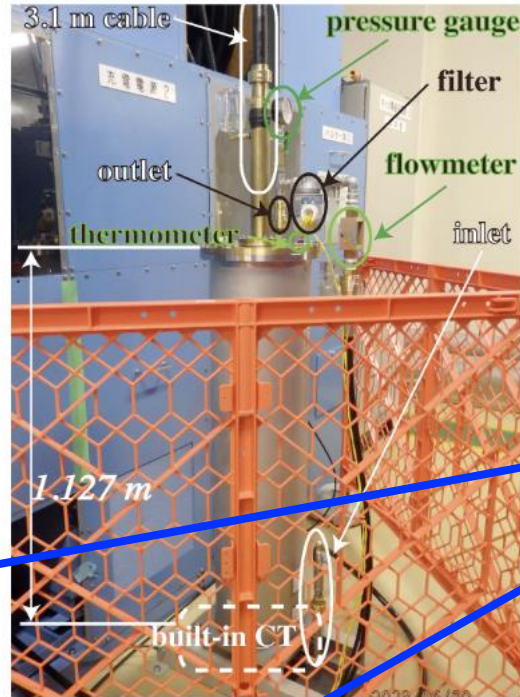
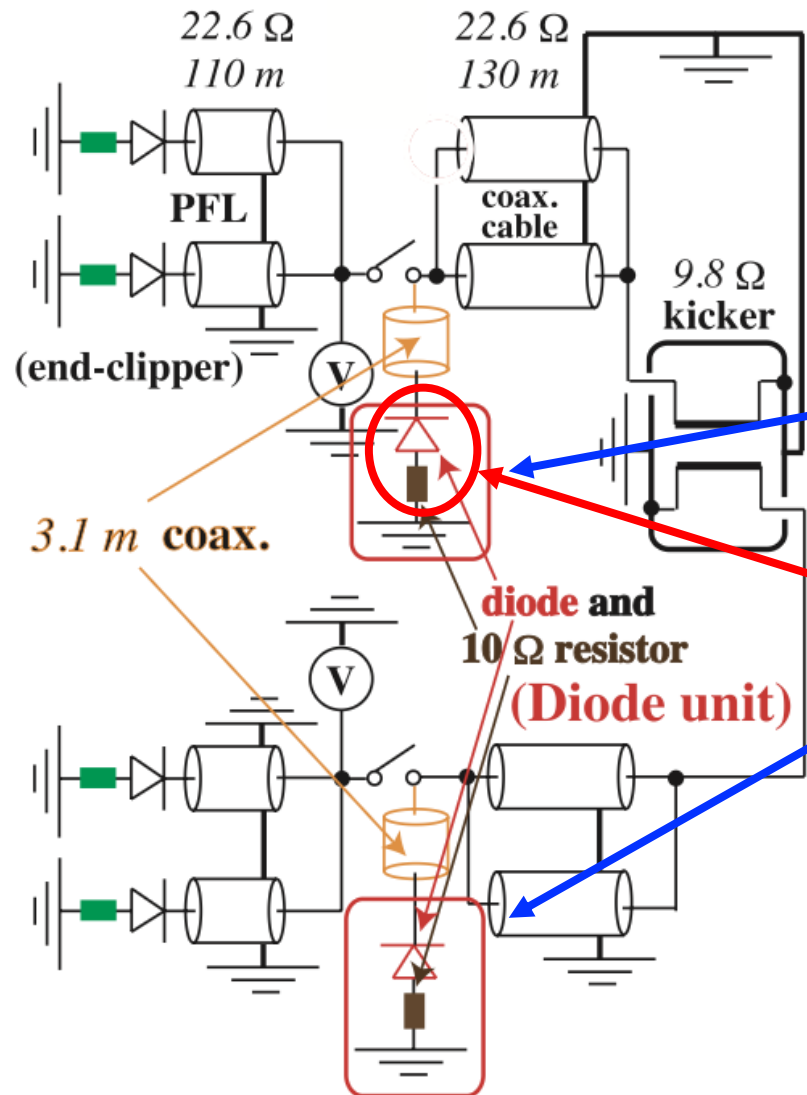

- ❖ Goal: retain power-saving advantage of original kicker design.
- ❖ Special diodes and matched resistors are inserted at upstream of thyatron switch (Shobuda *et al*, PRAB26, 053501, 2023, selected as editors' suggestion).
- ❖ This scheme secures doubled excitation currents, by blocking currents from Pulse Forming Line (PFL) from flowing into resistors.

## ❑ Kicker impedance, suppressed

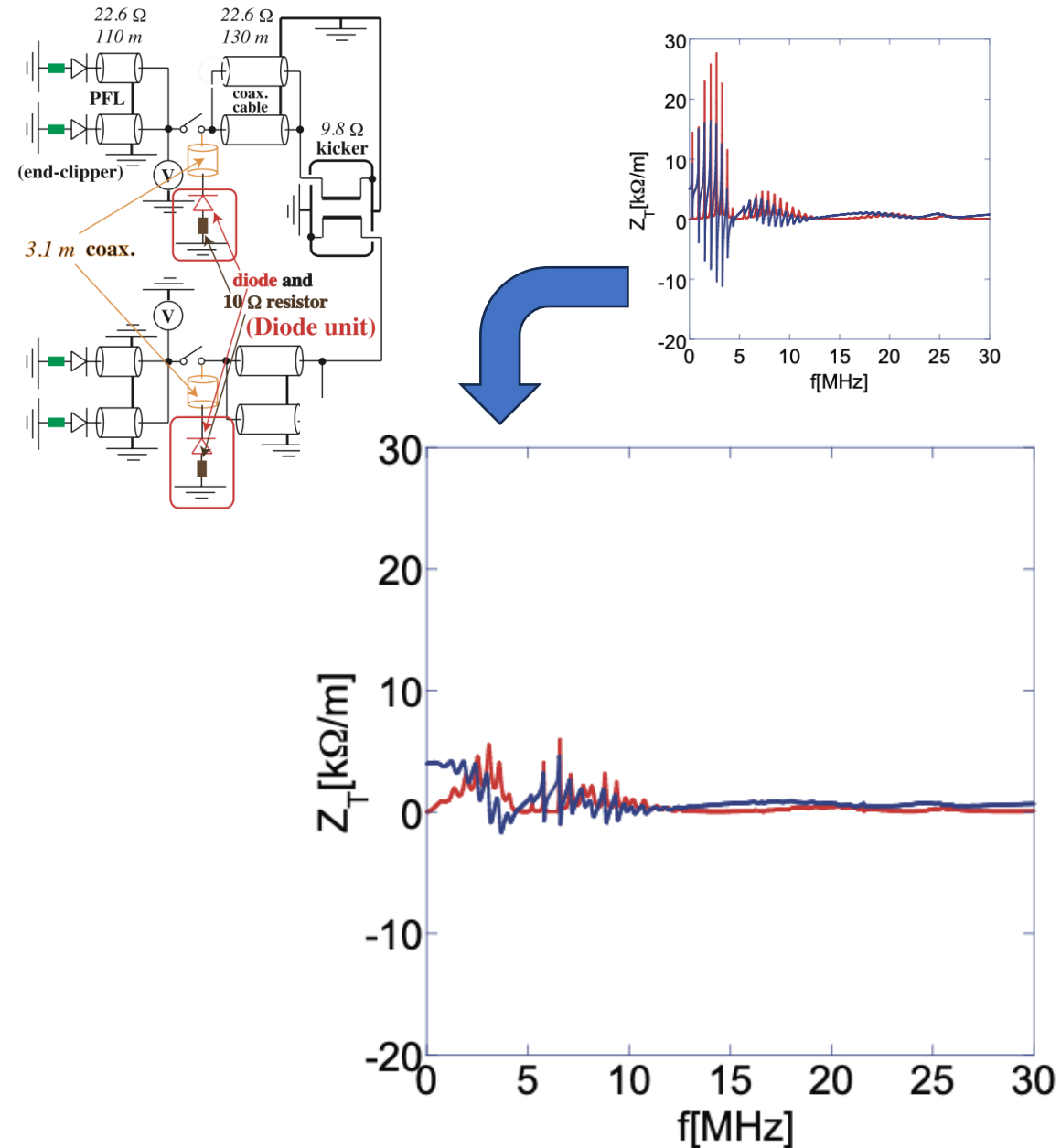

- ❖ Diodes act as capacitors and rectifiers for high-frequency beam-induced currents,
- ❖ which passes into resistors.

- ✓ A diode unit was installed in July 2021.
- ✓ Diode units have been installed into four out of eight kickers,
- ✓ with RCS delivering high intensity beams under routine operation.

## ➤ Performance of the impedance measure

- Eight kickers, numbered as Kicker 1, Kicker 2, *etc*,
- Diode units, systematically attached to respective kickers.

□ Evaluate Two diode units' impact on tune dependence (0.76 MW).

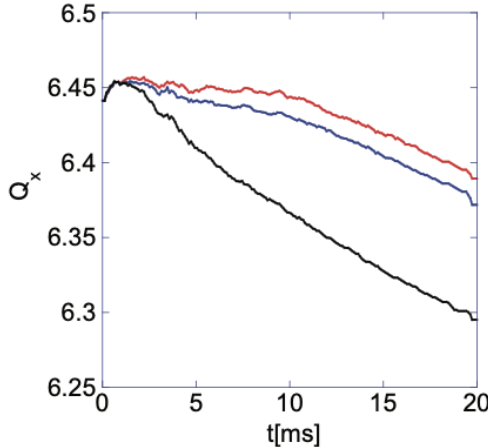

- Sextupoles, turned off after 10 ms.

Before the measure

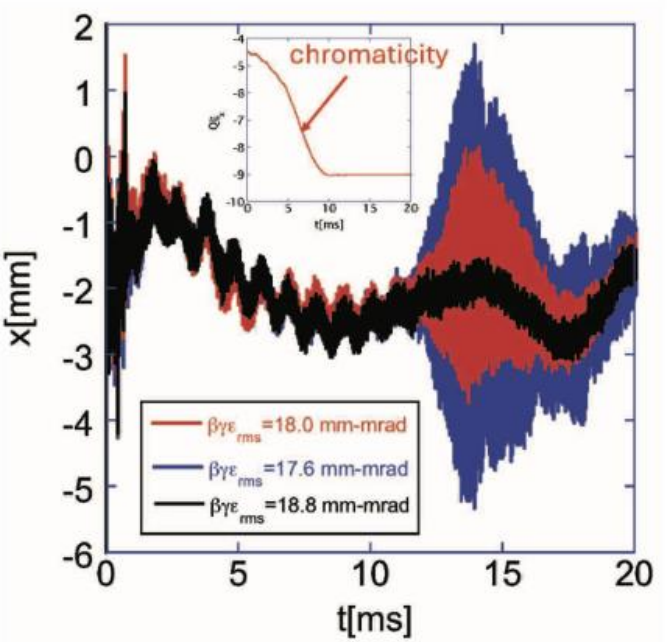

Kicker 8 attached

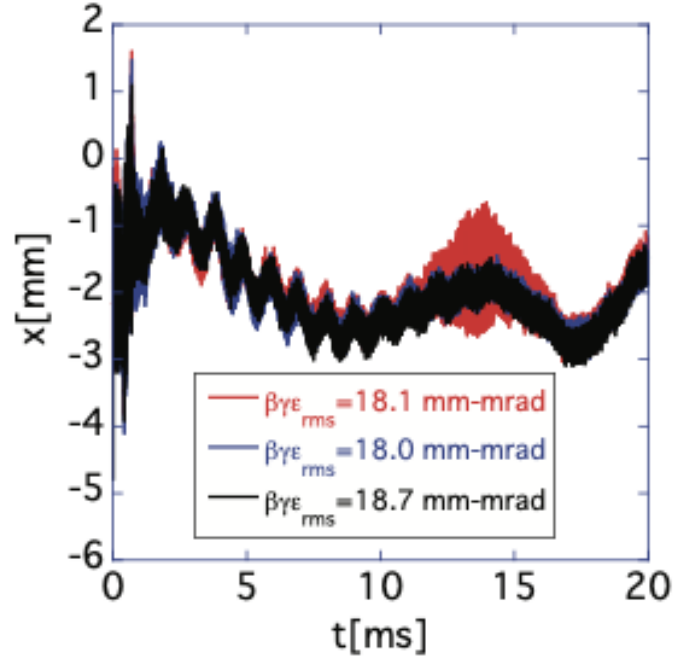

Kicker 5 & 8 attached

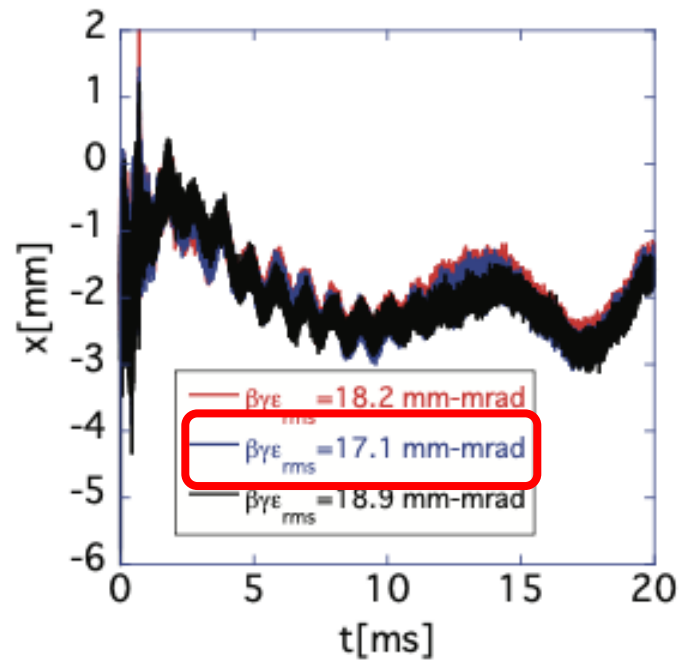

❖ Two Diode units eliminate tune dependence even for 17mm-mrad beams.

# Emittance dependence (0.76 MW), Sextupoles, activated by DC power supply

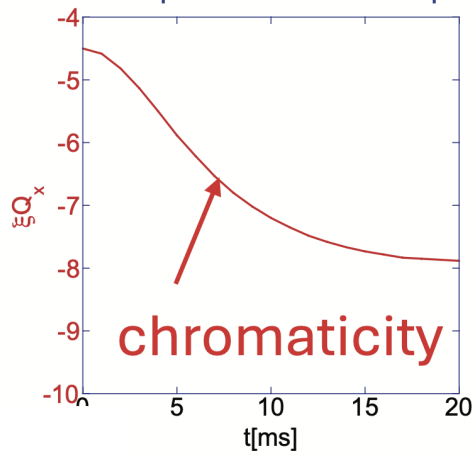

Emittances:

Red : 18 mm-mrad

Blue : 21 mm-mrad

Black: 35 mm-mrad

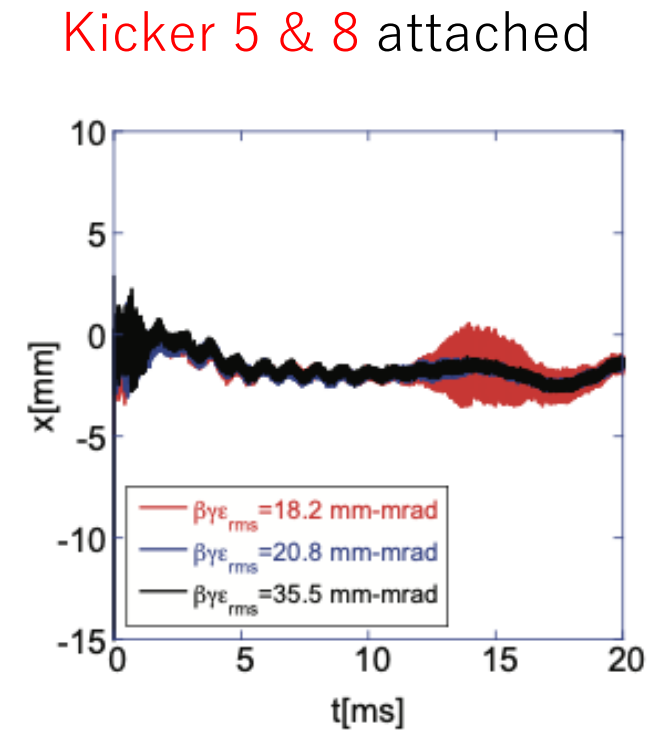
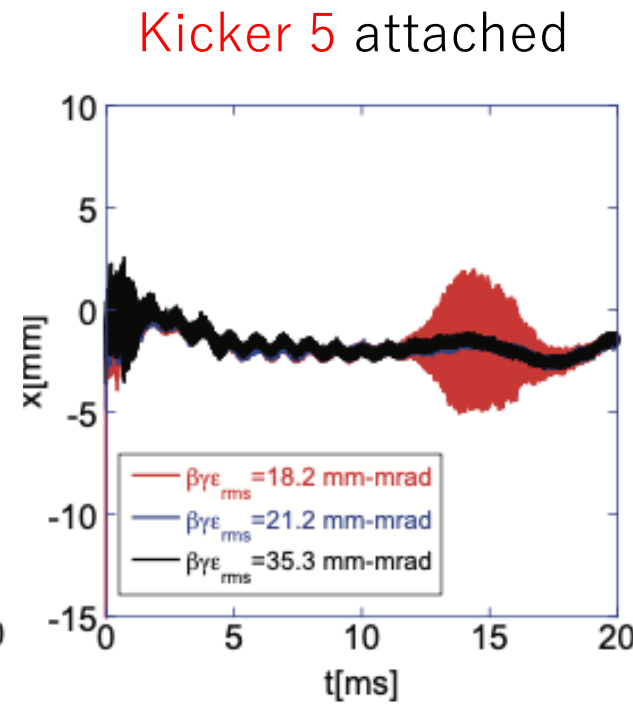
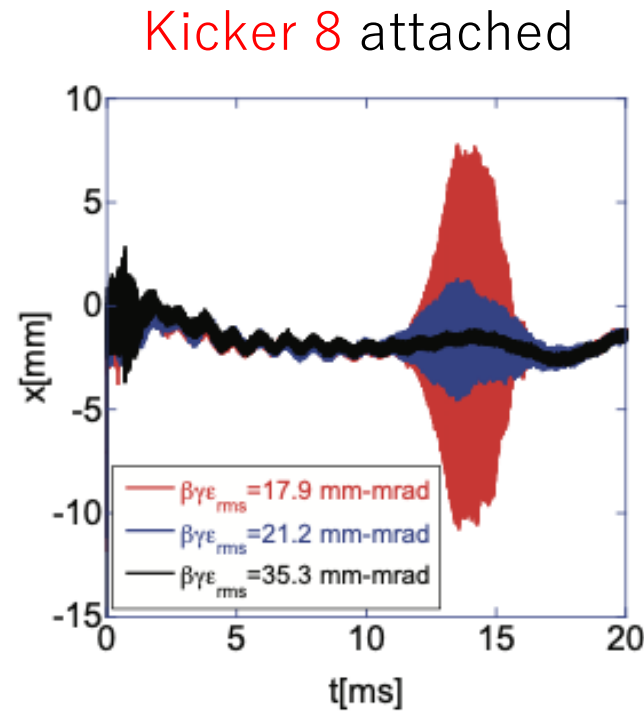

❖ Damping effects by diodes become more evident.

- Kicker-position dependence of damping effect comes from kicker-position's beta ( $\beta_x^{(5)} = 18.1$  m,  $\beta_x^{(8)} = 10.4$  m).

❖ Damping effect by indirect space-charge, independent of wake forms.

- Regardless of which kickers carry diode units, smaller emittance beams experience stronger beam instability.

Comparison with the theory for different diode settings (0.76 MW)

Kicker 8 attached @14ms

Kicker 5 & 8 attached @14ms

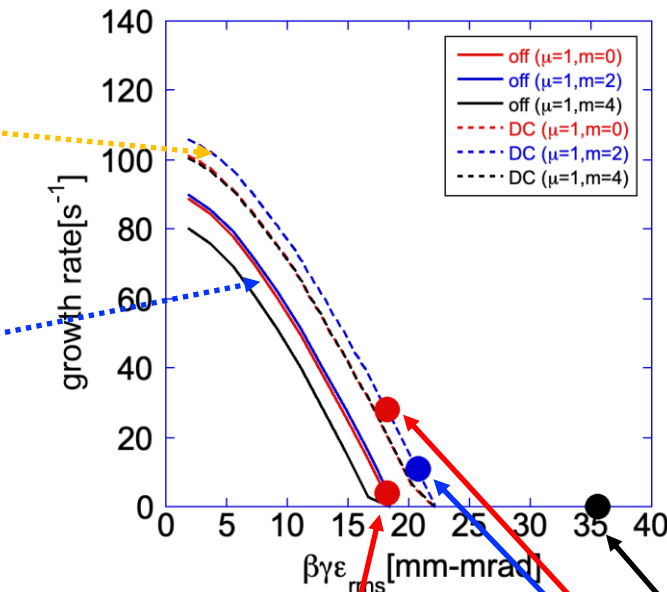
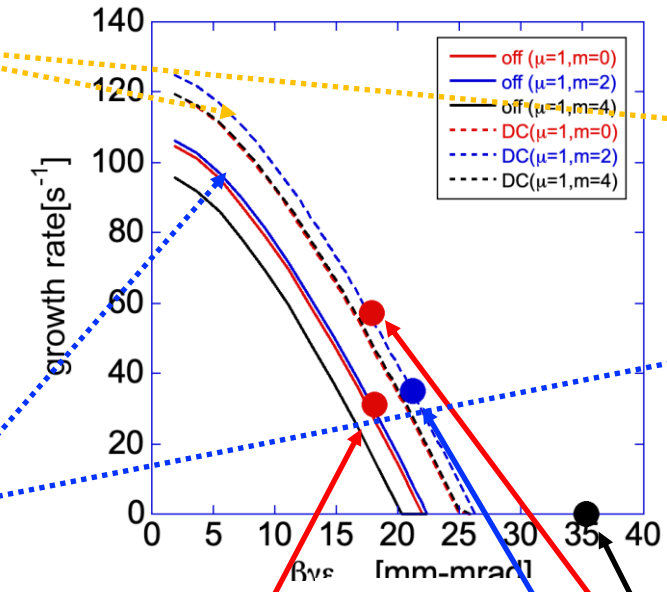
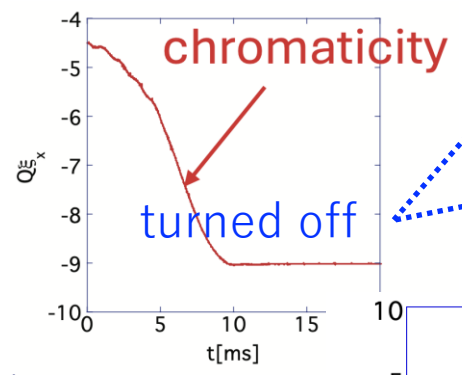
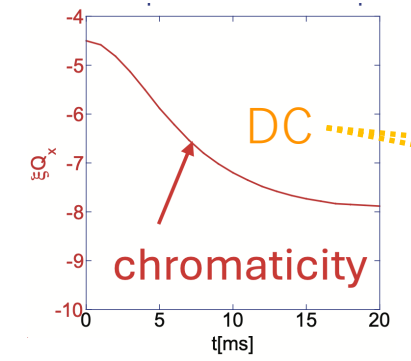

Emittances:  
 Red : 18 mm-mrad  
 Blue : 21 mm-mrad  
 Black: 35 mm-mrad

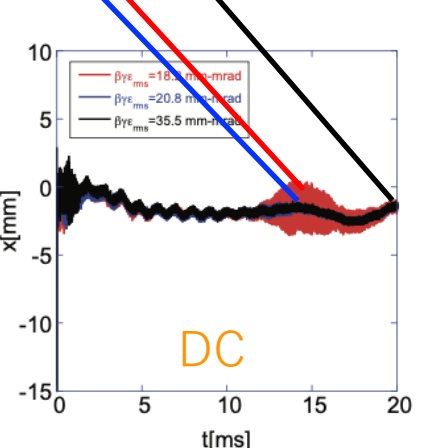
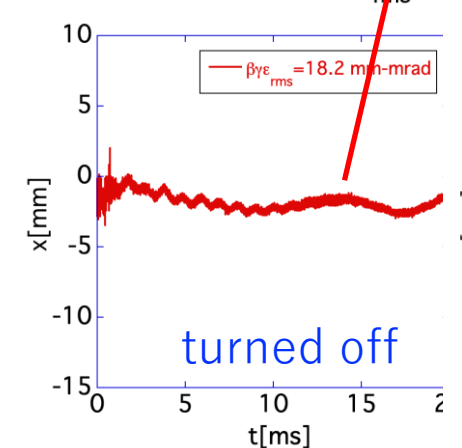
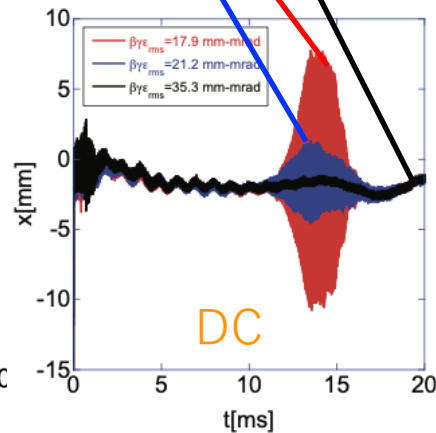
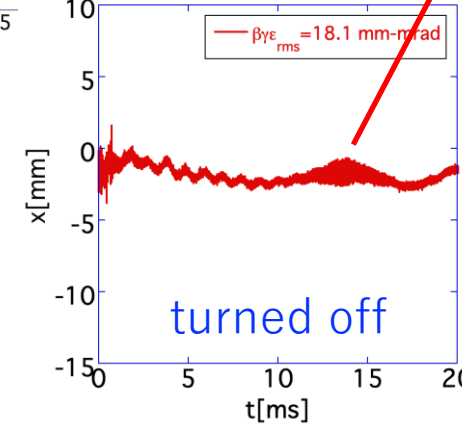

❖ Theory explains measurements.

❖ Critical emittances, below which beam instability must occur.

# □ Damping Effect with **Four** Diode Units (0.76 MW)

○ tune dependence

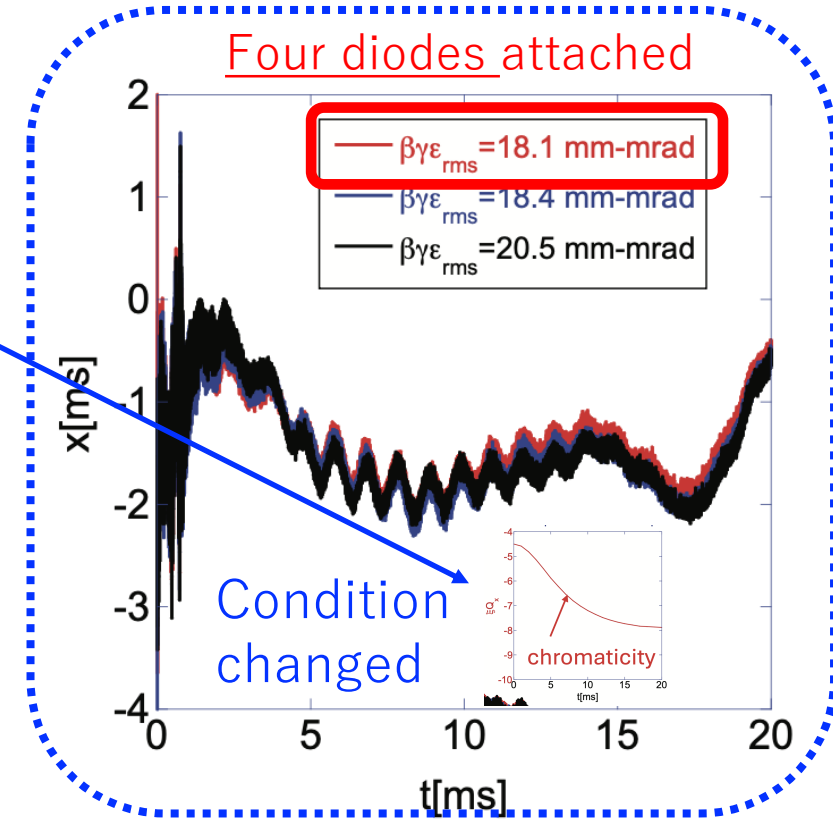
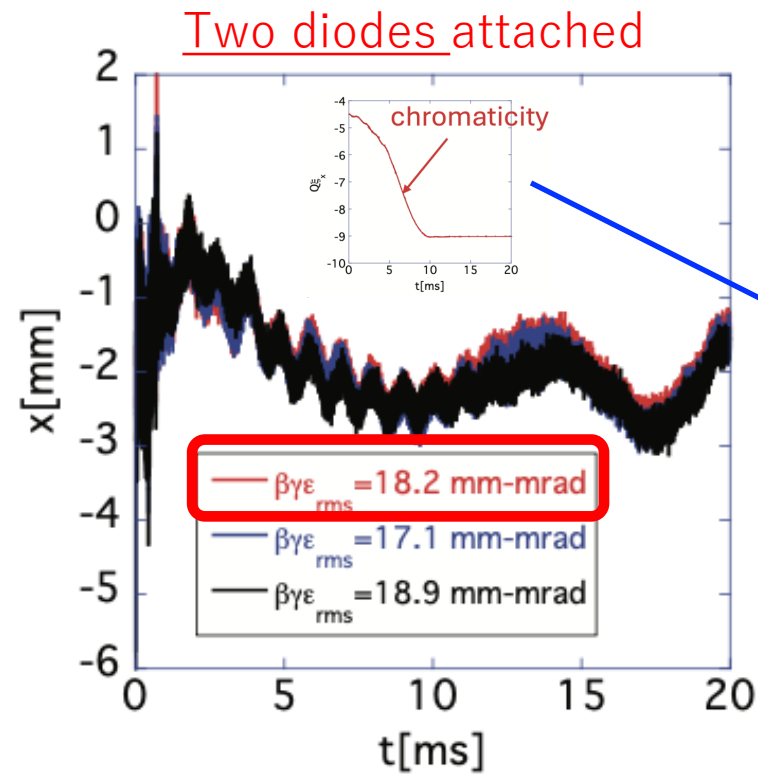
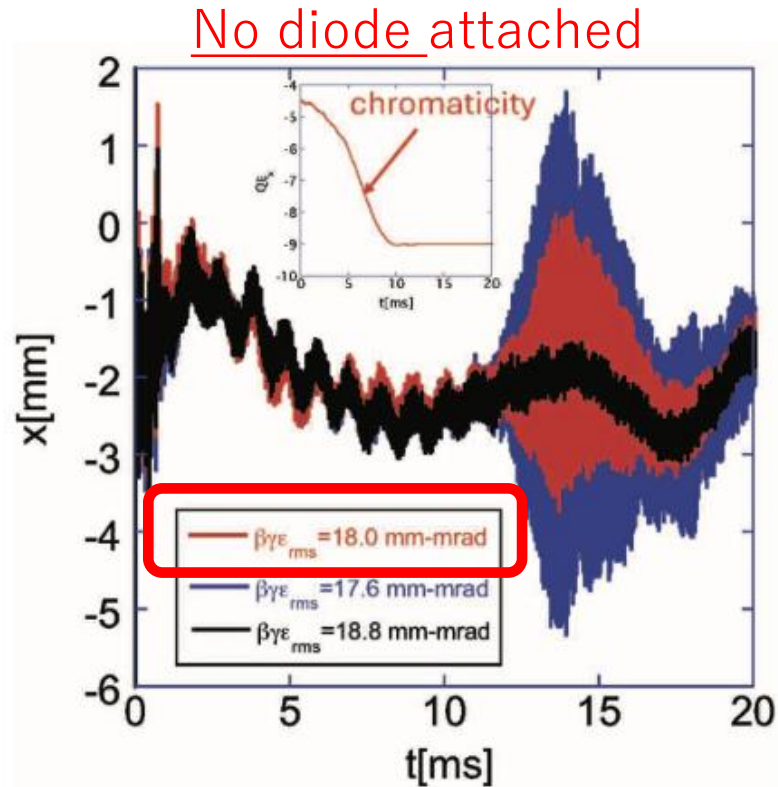

- **Two diodes** eliminate tune dependence.
- **Four diodes** suppress instabilities, **even for corrected** chromaticity cases.

❖ Installing four diode units widens the beam's operational tunability.

# Beam instability for 1-MW beam

## ❖ Unstable:

No diode attached

- broader emittance
- natural chromaticity

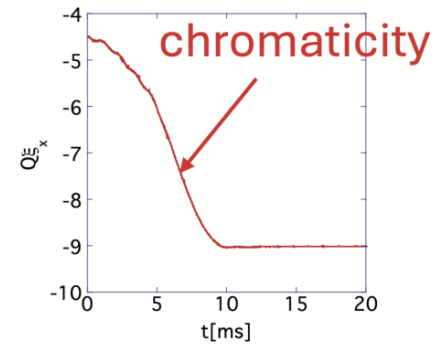
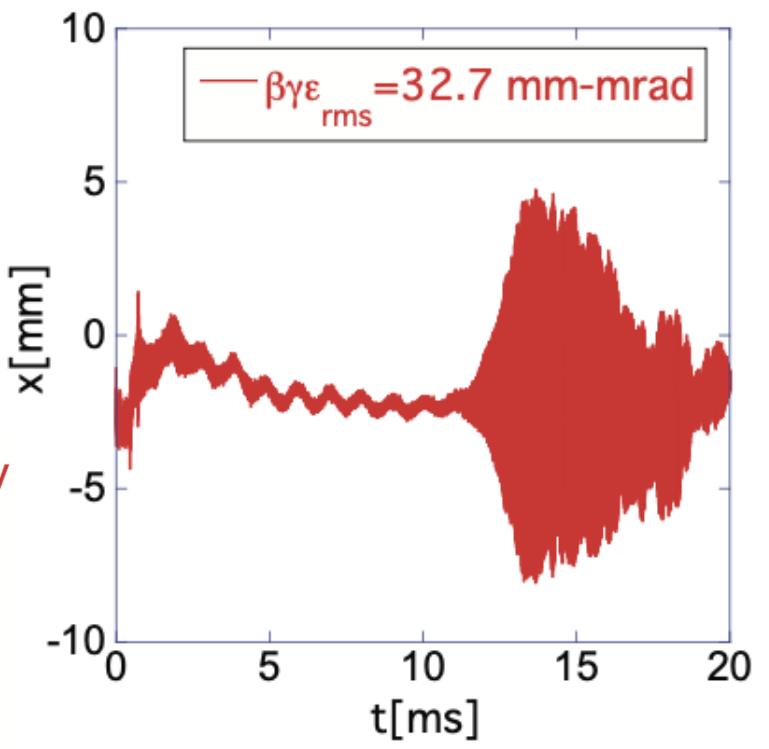

## ❖ Stable:

Four diodes attached

- smaller emittance
- corrected chromaticity

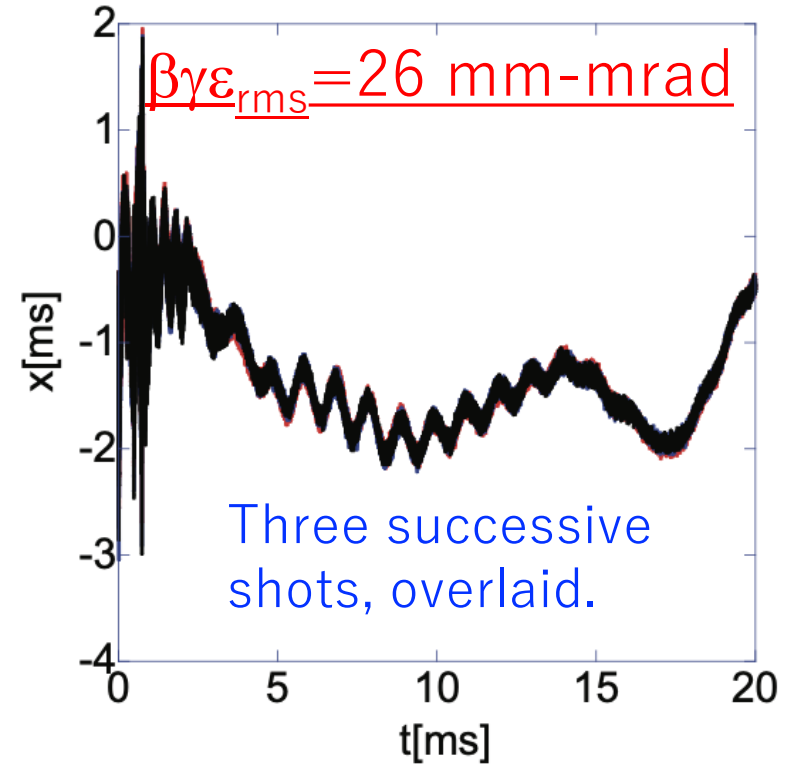
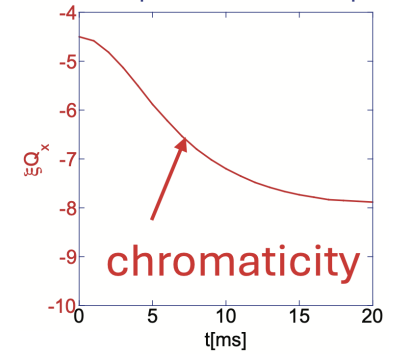

❖ Four diode units **suppress beam instability** with corrected chromaticity, for **1MW smaller emittance beams**.

# □ 2 MW Beam Growth Rate Estimation

- Beam growth rate @ 14 ms ( $Q_x=6.434$  and 14 ms)

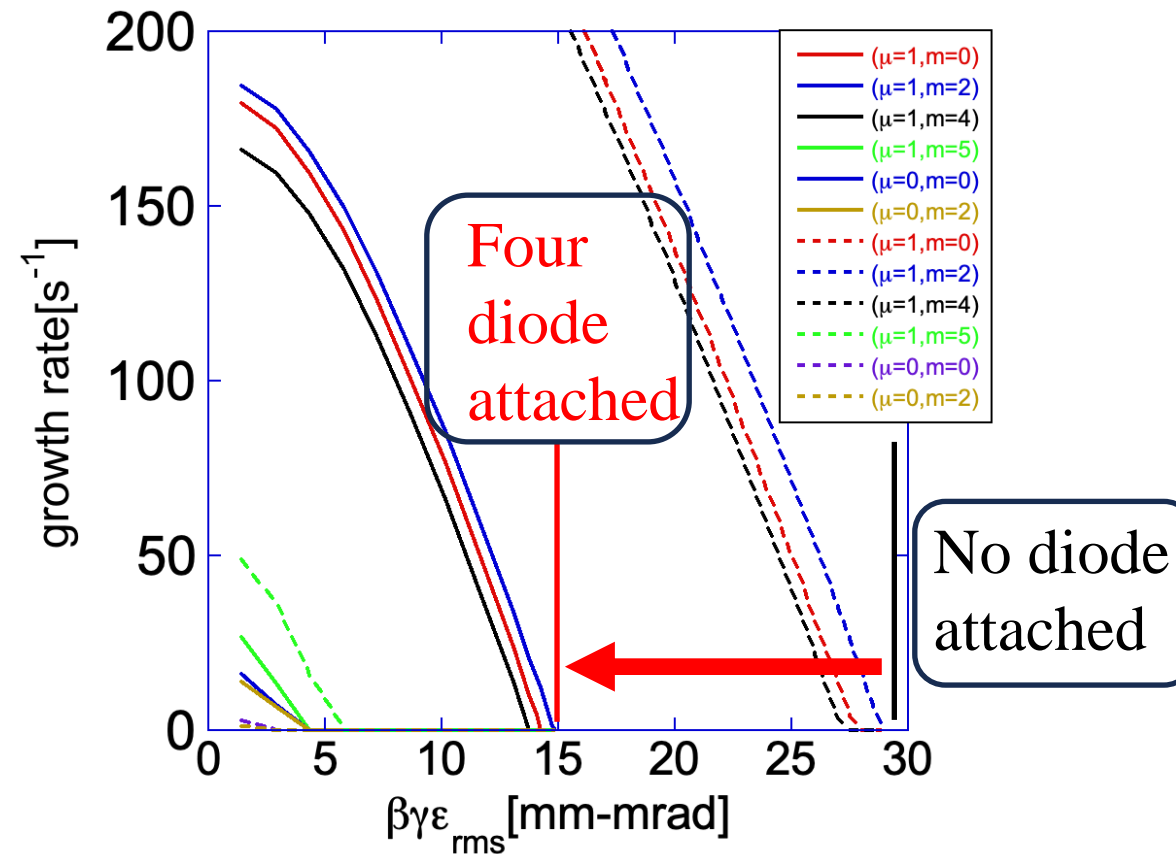
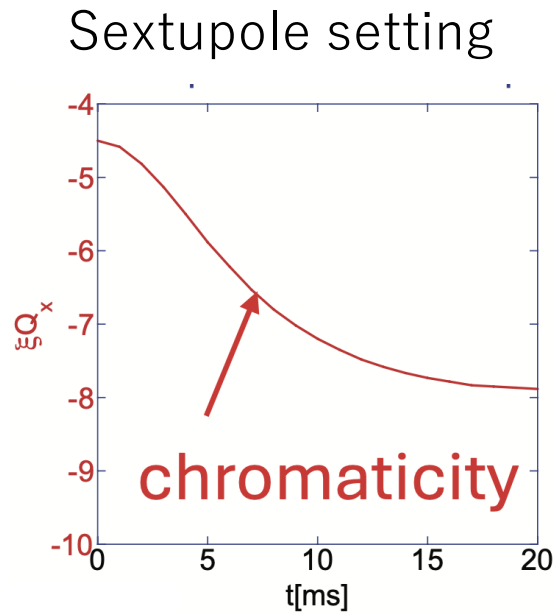

- Four diode units **reduce critical emittance** from 30 mm-mrad to 15 mm-mrad.

❖ Diode units and space charge expand **possibility of achieving 2 MW beam** *without* transverse feedback.

## ➤ Summary

- **Space Charge is Key:**

Indirect space charge enables high-intensity beams, with reduced feedback necessity.

- **Diode Unit Enhances Performance:**

Diode unit expands operational parameters, maintaining grounded kicker benefits.

- **Proven Reliability:**

Diode unit sustainability is being demonstrated through routine operation.