

The European Research Roadmap on Concepts and Technologies for Accelerators

Mike Seidel, PSI / EPFL, chair LDG

International Particle Accelerator Conference, Deauville, May 2026

European Strategy for Particle Physics:
Motivation for LDG Roadmap and
High Level R&D Goals for Accelerators / Colliders

Large Laboratory Directors Group (LDG): <https://ldg.web.cern.ch/>

LDG Roadmap for accelerator R&D: <http://arxiv.org/abs/2201.07895> ,
approved by CERN council 03/2022

Technologies and Concepts:

- 1) High Field Magnets
- 2) High Gradient RF Structures and Systems
- 3) High Gradient Plasma and Laser Acceleration
- 4) Bright Muon Beams and Muon Colliders
- 5) Energy-Recovery Linacs
- 6) Sustainability

mid 2026: **Update of European Strategy for Particle Physics by CERN Council**

[Recommendation Document](#) (16p) published December 2025

[Deliberation Document](#) published April 2026, and large-scale project [report](#)

2022 Accelerator Roadmap

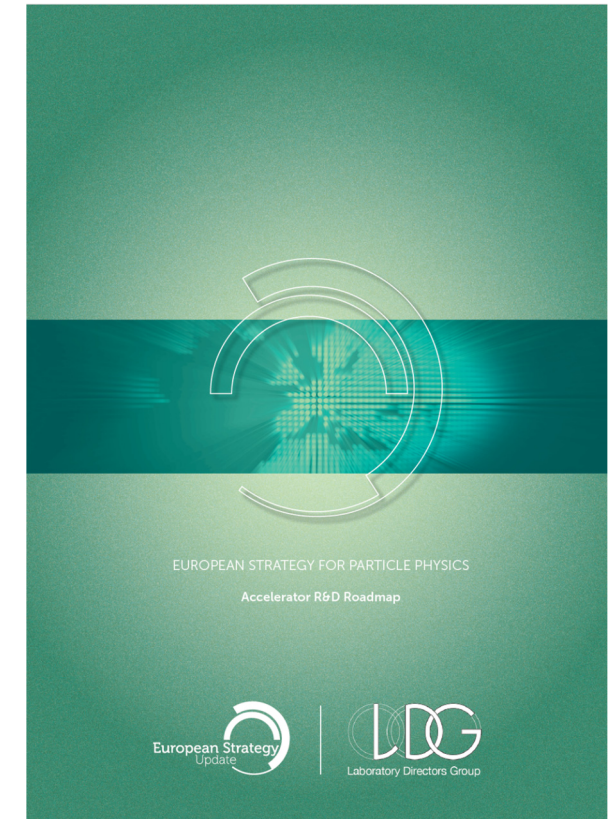

The electron–positron Future Circular Collider (FCC-ee) is recommended as the preferred option for the next flagship collider at CERN.

→ **the world’s broadest high-precision particle physics programme**, with an outstanding discovery potential through the Higgs, electroweak, flavour and top-quark sectors...

→ paves the way **towards a hadron collider** reusing the tunnel and much of the infrastructure, providing direct discovery reach well beyond the **10 TeV parton energy scale**, in line with the community’s ambition for **exploration at the highest achievable energy**.

→ **accelerator technology R&D for FCC ee and hh should receive priority**

1) ... the highest priority must be the development and industrialisation of key technologies:

- ▶ *accelerator-quality magnets in the 14–20 T range, including those based on high-temperature superconductors.*
- ▶ *advanced superconducting and normal-conducting RF structures*
- ▶ *efficient RF power sources*

2) demonstration of high-current multi-turn energy recovery in linacs constitutes an important step towards power-efficient lepton accelerators.

3) the longer-term development of advanced technologies at an appropriate level:

- ▶ *high-gradient wakefield acceleration*
- ▶ *technologies underpinning bright muon beams, exploiting synergies with the US initiative on muon collider R&D*

Collider Concept Choices

radiation power relative to electrons

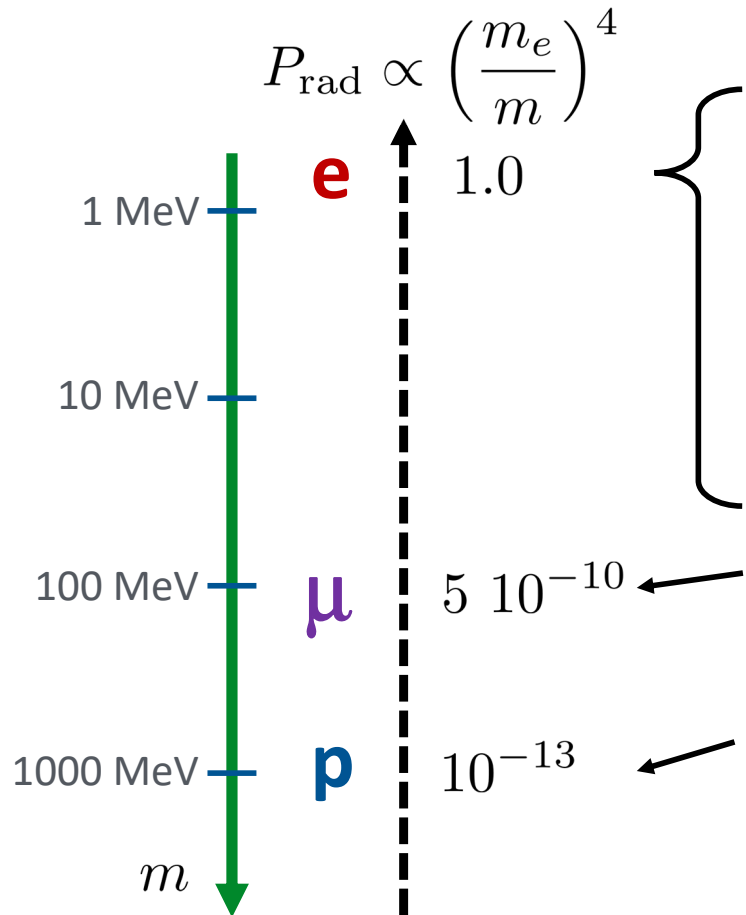

synchrotron radiation (SR) power differs by large factors for the particles under consideration

electron ring collider (FCC-ee): ESPPU recommended, very high luminosity through recirculation → but energy limited by SR, powerful **RF*** required

electron linear collider: no SR, but beam dumped immediately, **RF***

*energy recovery linac**: energy recirculated, not beam

*plasma acceleration**: high gradient, small footprint, intensity challenge

*muon collider**: SR & beamstrahlung suppressed, high energy for leptons

hadron ring collider (FCC-hh): highest parton collision energies, experience from LHC to analyse complex collisions, **high field magnets*** needed

*** accelerator roadmap activities**

The Importance of Design Tools: Xsuite

Numerical modelling is key for the design, commissioning and operation of next-generation facilities.

Increasing need for integrated, multi-physics studies: Optics and lattice design, single-particle dynamics, machine imperfections, collective effects, beam–matter interaction, radiation and damping, spin dynamics, polarization

Investment over the last years → Xsuite project:

- **Open-source** and **open to feedback and contribution from the community**
- **Python-based** → seamless integration with controls, optimization, AI workflows
- **Modular** → composable model, plug-in extensions
- **High performance & GPU acceleration**

More info at <https://xsuite.web.cern.ch/>

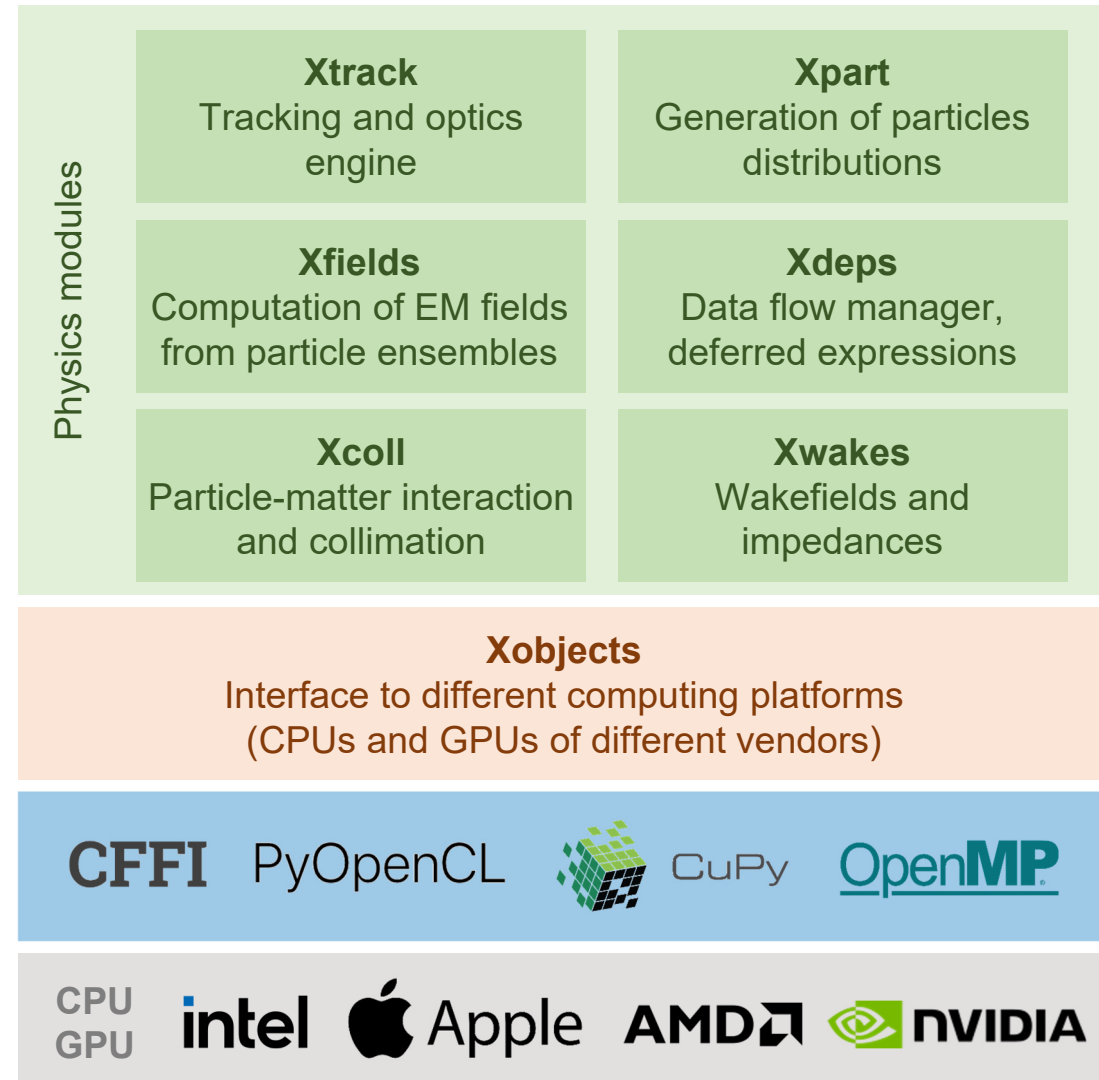

the main concepts in accelerators: **bending of trajectories** and **energy gain by RF fields**, profit from **energy efficient and high performance superconducting technology**

Magnets

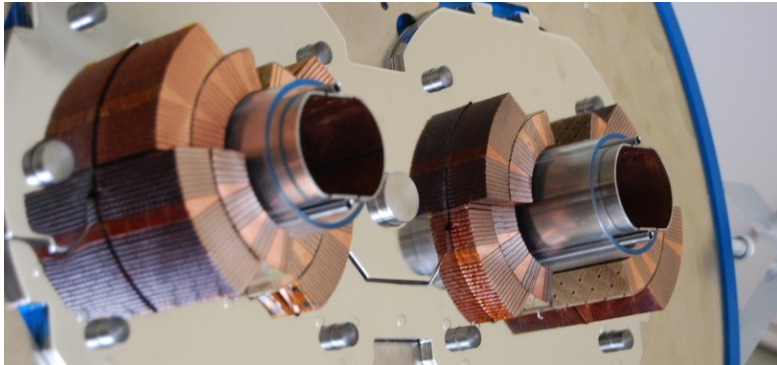

highest fields attainable

DC field: cooper pairs move frictionless

→ **zero losses**

RF Resonators



highest power transfer attainable

RF field: cooper pairs carry mass, causing imperfect RF field shielding

→ very small but **non-zero losses**

1) Technologies

High Field Magnets,

panel chairs: E.Todesco (CERN), B.Auchmann (PSI)

High Gradient RF Structures and Systems,

panel chairs: G.Bisoffi (INFN LNS), P.McIntosh (STFC)

HFM: FCC-hh 2025 Updated Baseline Parameters

		CDR 2019	2024-Nb ₃ Sn
Dipole field	(T)	16.0	14.0
Dipole aperture	(mm)	50	50
Magnetic length	(m)	14.3	14.3
Operational temp	(K)	1.9	1.9
Tunnel length	(km)	100	90.7
Arc length	(km)	82.0	76.9
Arc filling factor	(1)	0.80	0.83
Energy c.o.m.	(TeV)	50+50	42.5+42.5
Loadline fraction	(1)	0.86	0.80
J_c at 16 T and 4.2 K	(A/mm ²)	1500	1200
# dipoles	(1)	4587	4463
# quadrupoles	(1)	760	520

options (E.Todesco):

Operation at 4.5 K with the same magnet, significant reduction of power consumption of cryogenics [580MW(16T)→ 430MW(14T)→ ca 330MW(4.5K)]

Hybrid Nb₃Sn/Nb-Ti (large reduction in the mass of Nb₃Sn conductor, even more at 12 T, significant cost reduction)

20-m-long magnets (instead 15m, 25% less magnets to produce, plus a few more TeV or a bit more margin, an a bit cheaper magnet)

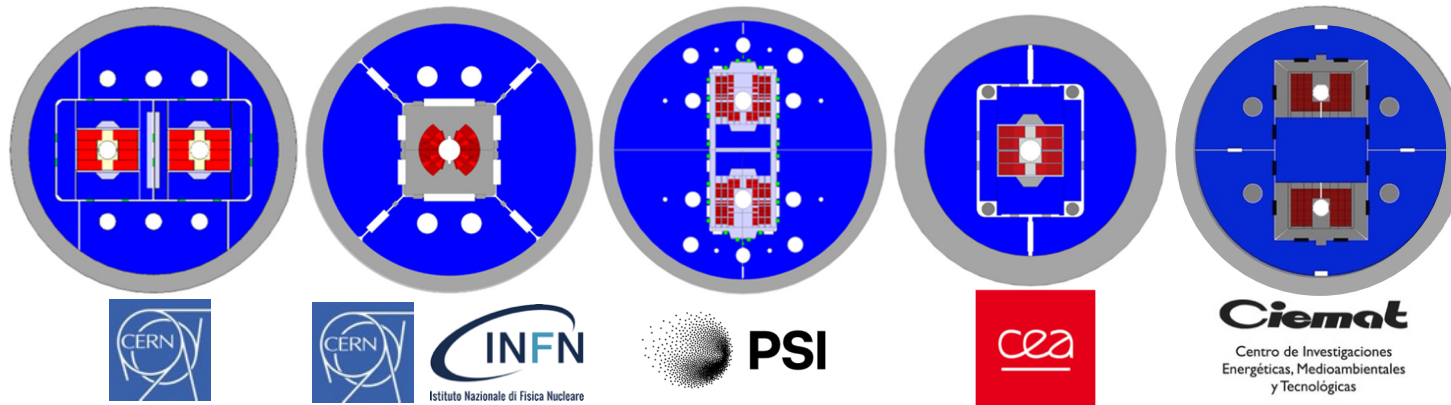

short model tests in 2026/27, then downselection

- Select the design by 2028/29 (first indications from HFM tests in 2026-2027)
- Short model program to verify reproducibility and optimize manufacturing processes: in 2029-2031
- Scaling in length in two steps: TRL 7 achieved between 2032 and 2040
- Industrialization for final magnets, with pre-series
- 9 years of production, installation and commissioning in parallel

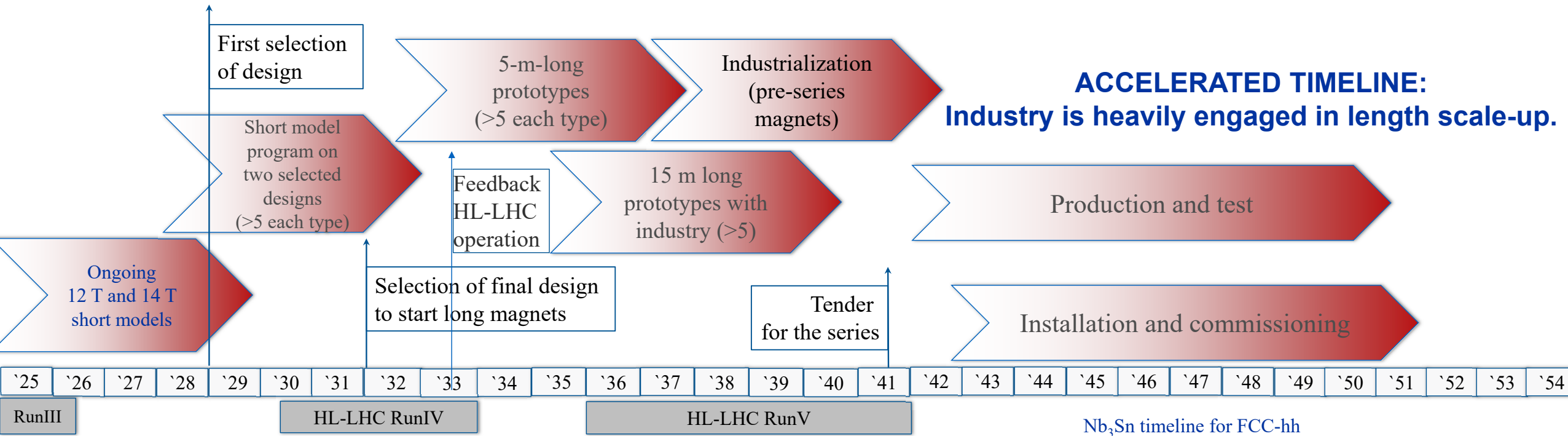

- ▶ **INFN activities: studies on ReBCO demonstrator**
 - ▶ 10 T field at 20 K, design to be selected between three variants
 - ▶ In synergy with other activities in INFN (ESMA, 10 T split racetrack)
- ▶ **CEA activities: metal insulated racetrack**
 - ▶ 5 T achieved without aperture
- ▶ **CERN activities: dielectric insulated racetracks with stack of 4 tapes**
 - ▶ 5 T achieved with 20 mm aperture
- ▶ **PSI activities: racetracks in a stress managed structure**
 - ▶ First tests in July 2026

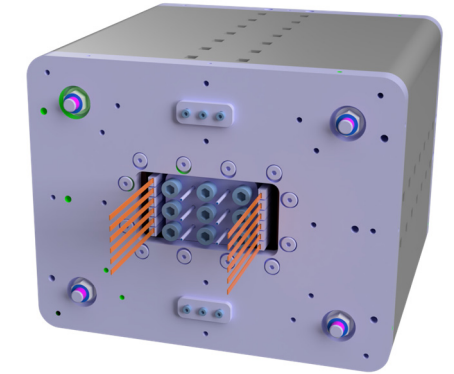

FLARE demonstrator [A. Baskys, A. Ballarino et al.]

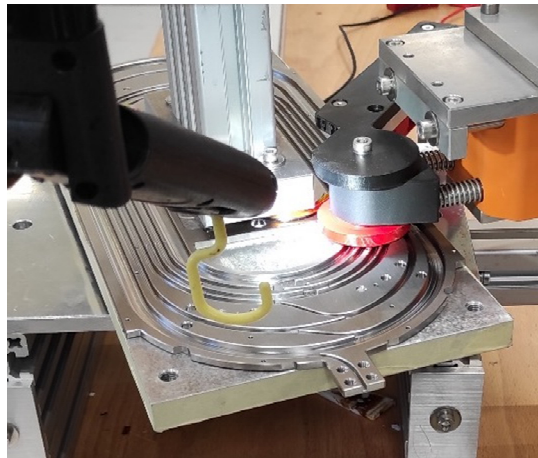

Winding of HTS racetrack in a former [D. Araujo, et al.]

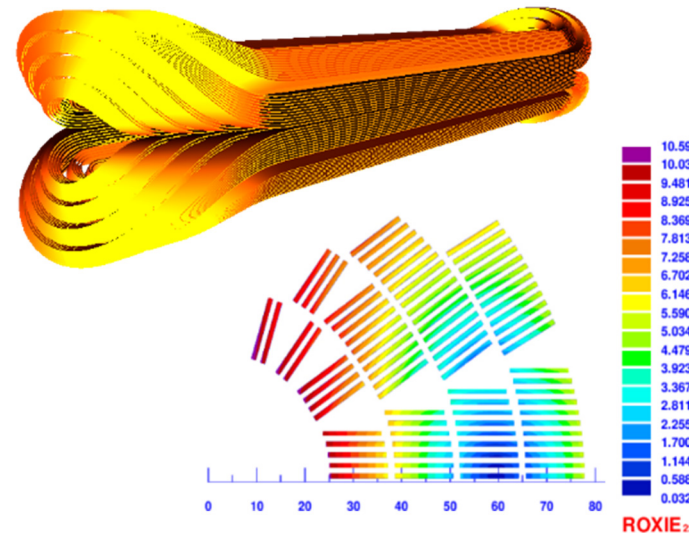

One of the options for 10 T, 20 K dipole [M. Statera, et al.]



NARSIL stack in the structure
Narsil MI coil [T. Lecrevisse et al.]

FCC-hh specific

- optimize for 14 T double aperture magnets → best compromise grid power / energy reach / cost
- study hybrid Nb₃Sn / NbTi coil configurations (cost)
- system integration → field quality/ramping; SR power extraction; vacuum; e-cloud; dust particles; reliability of ca 5000 magnets
- length scaling of initial prototypes to 15-20m
- magnet cost and industrial supply
- determine target specs for HTS FCC magnets

generic - LTS

- fast development cycles for test models, sub-scale tests
- price reduction of high performance Nb₃Sn wire
- ultimate performance of Nb₃Sn wire
- design/mechanical concepts that scale to field > 14 T or large apertures (>100 mm)
- protection concepts

generic - HTS

- identifying the most suitable HTS cables for magnets and coil technology for high current density magnets
- ramp losses and field quality with tape cables
- profiting from operation at higher temperature; cryogenic systems for >=10K operation
- protection concepts

LDG - RF Panel	G. Bisoffi INFN, P. McIntosh STFC
WG1 Bulk Nb	M. Baylac CNRS, C. Madec CEA, L. Monaco INFN
WG2 Thin films	O. Malyshev STFC, T. Proslie CEA (C. Antoine CEA)
WG3 Couplers	F. Gerigk CERN, A. Neumann HZB (E. Montesinos CERN)
WG4 NC High gradient	W. Wünsch CERN, D. Alesini INFN
WG5 RF Power sources	I. Syratchev CERN, G. Burt STFC, M. Jensen ESS
WG6 LLRF, AI, ML	W. Cichalewski U-Lodz (Z. Geng PSI)

- **RF Coordination Panel (RFCP)** was established in 2022 to support **implementation of the ESPP-U 2020 roadmap**, coordinating RF R&D activities across CERN and LDG laboratories and identifying common priorities.

- ▶ Following an LDG Review in 2025 and ESG recommendations, the RFCP was asked to focus on a limited set of high-impact and cross-cutting technologies aligned with realistic resources and collider timelines:
 - advanced SC/NC RF structures **Bulk Nb cavities**
 - high-efficiency RF power sources **Thin film cavities**
 - high-current ERLs **High-η RF sources**

– *in a longer-term: wakefield acceleration and MC technologies.*
- ▶ The RFCP then carried out a systematic analysis of **RF priorities for the main collider options** (FCC-ee/hh, LCF, LEP3, LHeC, Muon Collider, HALHF), using **TRL6 by 2031** as the common reference target, evaluating:
 - ▶ Performance **gaps**
 - ▶ Remaining **challenges**, with emphasis on synergies, reliability and energy efficiency.
 - ▶ Required infrastructures and resource **needs**
 - ▶ Laboratory engagement

BULK NB CAVITIES

Applied in many collider schemes

Roots: exceptional expertise made on **1.3 GHz** (800 cavities pulsed on Eu-XFEL, 400 cavities CW on LCLS-II-HE, 600 cavities CW on SHINE, Shanghai), and the ILC/ITN multi-decade developments.

LCF: higher Q (by improved surface/thermal treatments), tests planned at KEK in 2026-2027

FCCee: transfer of LCF expertise at 800 MHz (mid-T baking, f-dependence and flux trapping to be investigated)

LHeC: targets and R&D path similar to FCCee at 800 MHz (and to PERLE in France)

LEP3 would also require bulk-Nb 1-cell, 4-cell, 6-cell cavities, at **800 MHz** and 500 kW (higher than state-of-the-art), requiring effort on FP-couplers/RF sources

Labs with TRL6* (and European with TRL7 *) expertise: CEA, CERN, CNRS/IJCLab, DESY, ESS, HZB, INFN, STFC, UHH, Uppsala/FREIA, et al.

(Eu),

FNAL, JLAB, SLAC, et al. (Am),

KEK, IHEP, SHINE, Korea Univ. Et al. (Asia)

iSAS European Project: rationalising R&D on 800 MHz; joint experiments on 1.3 GHz

X 856

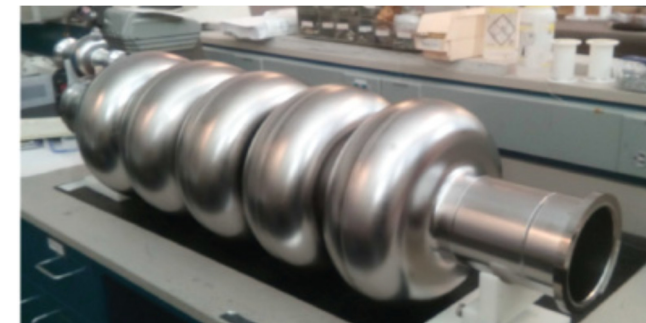
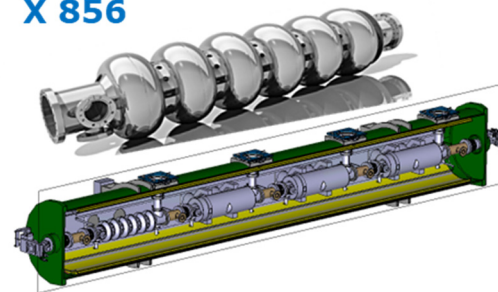

FCCee - 800 MHz, full Nb, @2 K ($2\times$ LCLS-II Q_0)

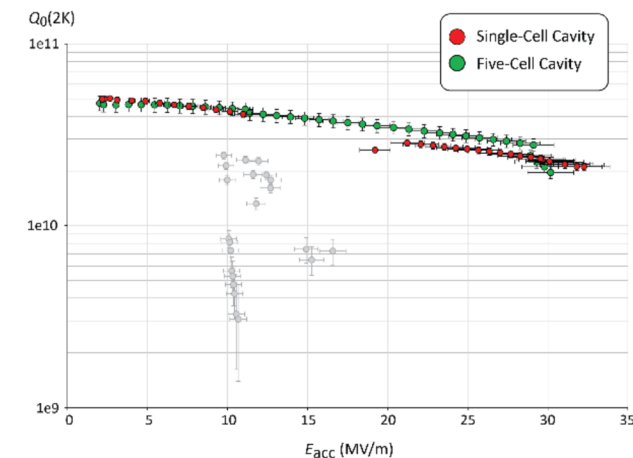
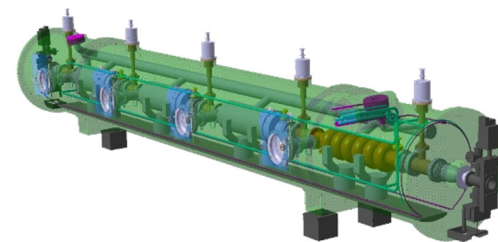

CURRENT STATE OF THE ART:

- 5-cell prototype **w/o** ports, built by JLAB: 3×10^{10} , ~ 30 MV/m **in VT (Vertical Test)**
- CERN-now: **1-cell cavities under fabrication** (deep-drawing and EBW), collab **with FNAL, IJCLab, Cornell U and others.**
- **Short-term goal:** recipes for needed Q_0 factor at high gradient. **Final goal:** 6-cell cavity, at TRL7 (test in CM) 3×10^{10} , 20.25 MV/m

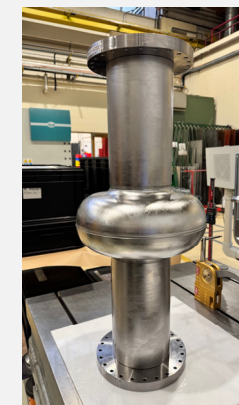

THIN FILM CAVITIES

Nb/Cu

FCC_{ee} to implement Nb/Cu (an ameliorated LEP tech) on 2-cell 400 MHz cavities (lower material impact, same energy).
MC may adopt Nb/Cu cavities with 2x E_a (very ambitious for now).
It may be the long-term goal for the LHeC collider option.

HIGHER T_C MATERIALS

Lower R at 4K versus Nb → higher operating T → smaller energy quest.

- Nb₃Sn the most mature: promising Nb₃Sn/Nb (good for energy saving not for material saving);
- Nb₃Sn/Cu real goal (material and energy saving).
- Other thin-film options are farther from the goal

The production of high-quality Cu bases is paramount (and critical).

TF-collaboration very well integrated, little resources.
IFAST, iSAS and EPITA Projects nicely complementary, fostering infrastructures with standardized equipment and processes.

X 264

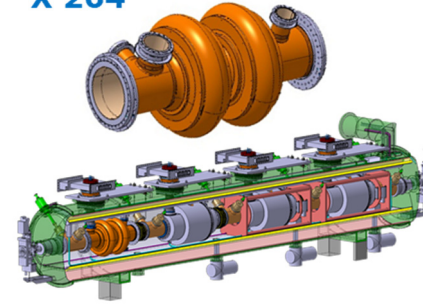

400 MHz, Nb/Cu thin film, @ 4.5 K (2x LHC E_a and Q_0)



FCC_{ee}

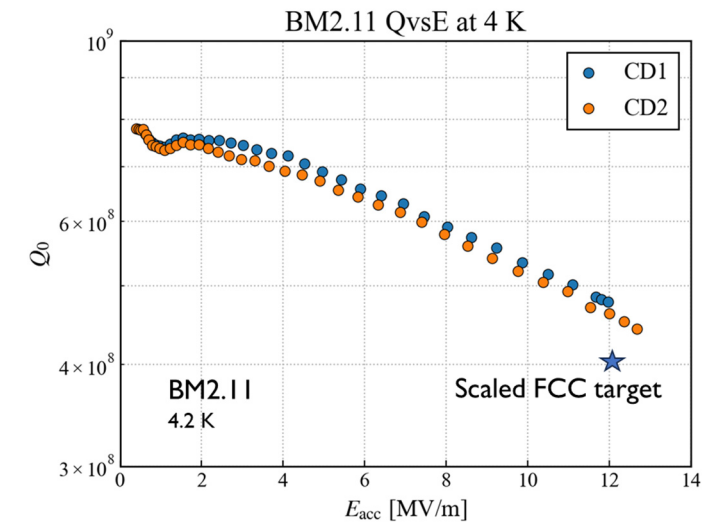

From the old LEP2 expertise:

- Scaled (1.3 GHz) FCC targets for E_a and Q_0 have been reached on [bulk-machined seamless Cu](#) bases, with a good reproducibility
- Chemical electropolishing; Nb coating with High Power Impulse Magnetron Sputtering (HiPIMS).
- Promising preliminary results obtained recently on [hydroformed cavities](#) within the CERN-KEK collaboration.

HIGH EFFICIENCY AMPLIFIERS

- RFCP-WG5 supported/promoted development of high efficiency RF power sources for future large-scale particle accelerators.
- Intense collaboration with industry to ensure long-term industrial support for decades to come.
- For all collider schemes: some adaptations required, power goals within reach.
- All are aiming at ~ 90% efficiency, from present ~ 70%.
- MB Tristron prototyped internally at CERN, all resources and competences allocated.
- Fabrication and testing will be the next step.

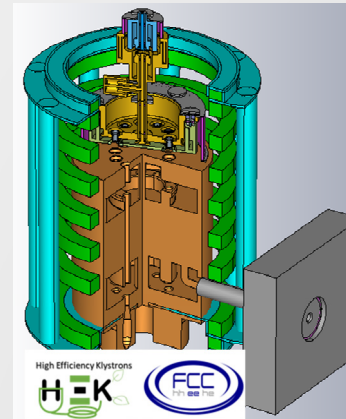

FCC klystron **efficiency** gain from 70% to 90% can save > 1 TWh **in 10-years**

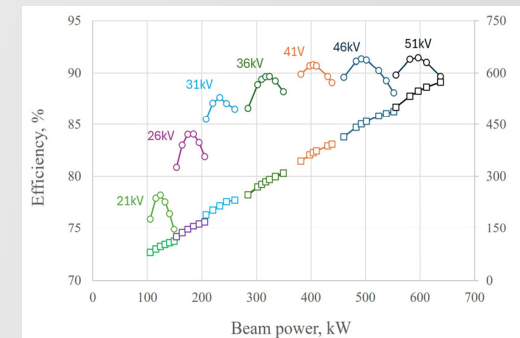

FCC_{ee} x 264 400MHz, 0.5MW, CW
MB Tristrons, $\eta=90\%$, OPEX !!

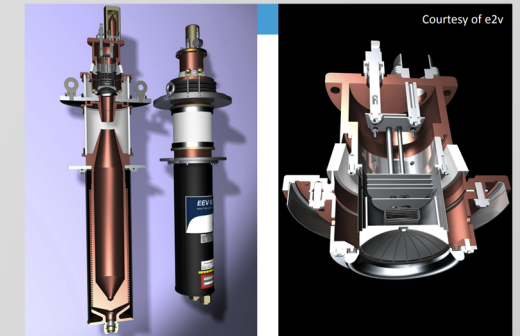

FCC_{ee} 800 MHz, 50-250 kW
CW, Tristron or high- η IOT

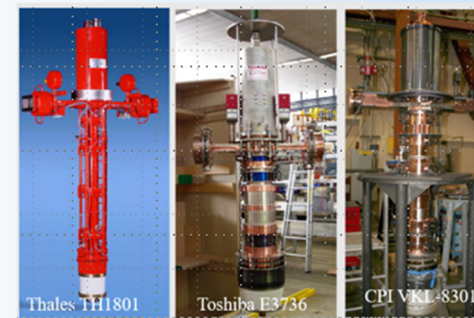

Frequency: **1.3 GHz**
Peak RF power: 10 MW
Efficiency: 65%

LCF - $\eta=80\%$ **power sources**,
reachable with dedicated R&D

2) Advanced Collider Concepts

High Gradient Plasma and Laser Accelerators,

panel chairs: W.Leemans (DESY), R. Patathill (STFC)

Bright Muon Beams and Muon Colliders,

panel chairs: D.Schulte, S.Stapnes (CERN)

Energy Recovery Linacs,

panel chairs: J.D'Hondt (NIKHEF), A.Stocchi (IJCLab)

HALHF: A hybrid, asymmetric, linear Higgs factory

Provides a concept that can fit in many major particle physics labs

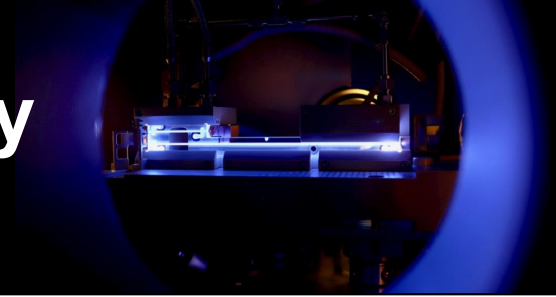

Foster et al., Phys. Open 23, 100261 (2025)

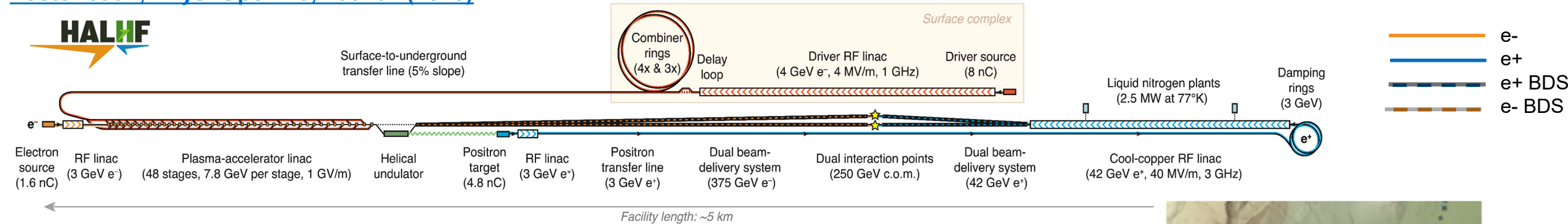

- Exploit high gradient of e^- acceleration in PWFA and avoid difficulty of e^+ acceleration by using conventional RF linac, reducing cost by low $E(e^+)$ (**42 GeV**) \Rightarrow high $E(e^-)$ (**375 GeV**), boost $\gamma \sim 1.7 \Rightarrow E_{CM} \sim 250 \text{ GeV}$.
- Reduce running costs by increasing current $I(e^+)$ and reducing $I(e^-)$; this & asymmetric emittance (increased for e^-) ease PWFA requirements.
- PWFA stage length $\sim 1100\text{m}$ (PWFA gradient $\sim 1 \text{ GV/m}$; gradient $> \sim 0.33\text{GV/m}$) \Rightarrow facility length $\sim 5 \text{ km}$
- Cost $\sim 68\%$ of CLIC - **4.9BCHF**
- *Current luminosity/power & luminosity/cost estimates for HALHF compared to CLIC: 21% & 29%**

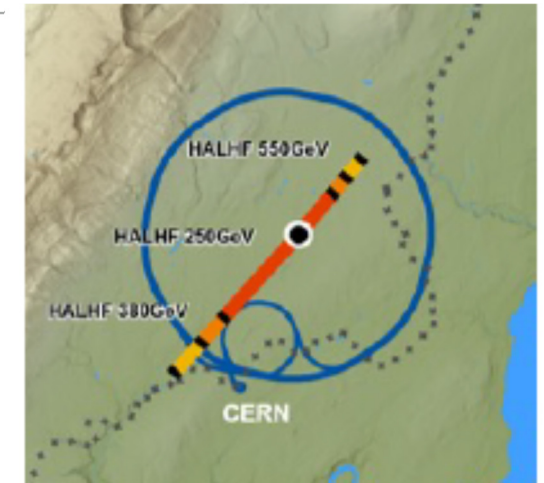

- Still not too big to fit in major particle physics labs
- Detailed parameter set is being worked out, based on **integrated simulations** of the main linac.
- Parameters will also be studied for a **550 GeV machine** (or other desired energies) – straight forward scaling.

EuPRAXIA provides complementarity

Beam-driven : INFN, Frascati, Laser-driven : ELI-BL, Prague

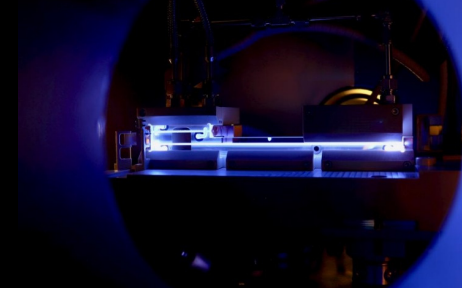

addressing key challenges, e.g. low emittance beams, stable & reliable operation

 2 Implementation Pillars
@ INFN - LNF & @ ELI-ERIC

 Several National Nodes. Roles to be fully defined

 Project Clusters

A large collection of European know-hows in accelerators, lasers and plasma technologies

- Network organization
- Sites (PWFA/LWFA): new users facilities
 - National nodes
 - Technology clusters

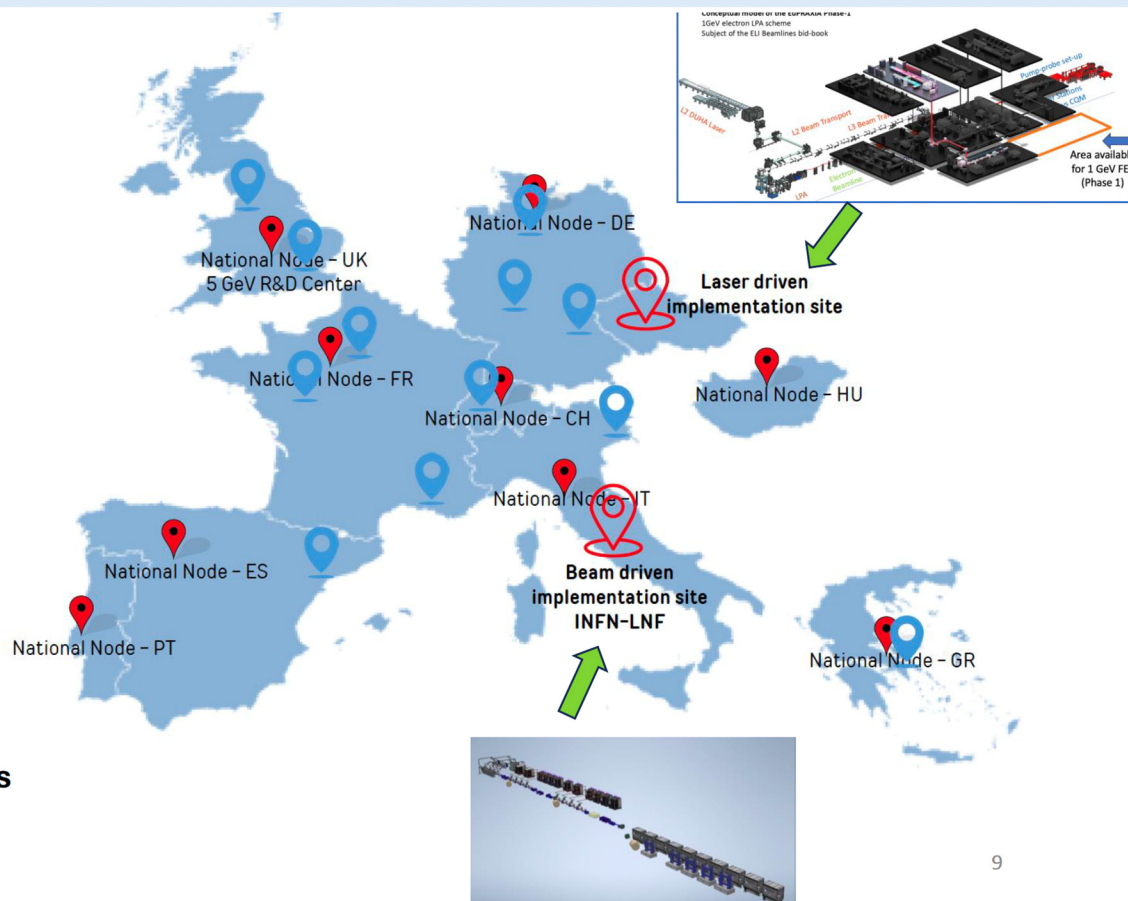

FEATURE EuPRAXIA

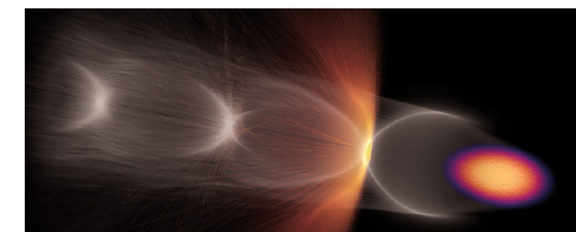

Surf's up Simulation of electron-driven plasma wakefield acceleration, showing the drive electron beam (orange/purple), the plasma electron wake (grey) and wakefield-ionised electrons forming a witness beam (orange).

EUROPE TARGETS A USER FACILITY FOR PLASMA ACCELERATION

Ralph Assmann, Massimo Ferrario and Carsten Welsch describe the status of the ESFRI project EuPRAXIA, which aims to develop the first dedicated research infrastructure based on novel plasma-acceleration concepts.

Energetic beams of particles are used to explore the fundamental forces of nature, produce known and unknown particles such as the Higgs boson at the LHC, and generate new forms of matter, for example at the future FAIR facility. Photon science also relies on particle beams: electron beams that emit pulses of intense synchrotron light, including soft and hard X-rays, in either circular or linear machines. Such light sources enable time-resolved measurements of biological, chemical and physical structures on the molecular down to the atomic scale, allowing a diverse global community of users to investigate systems ranging from viruses and bacteria to materials science, planetary science, environmental science, nanotechnology and archaeology. Last but not least, particle beams for industry and health support many societal applications ranging from the X-ray inspection of cargo containers to food sterilisation, and from chip manufacturing to cancer therapy.

This scientific success story has been made possible through a continuous cycle of innovation in the physics and technology of particle accelerators, driven for many decades by exploratory research in nuclear and particle physics. The invention of radio-frequency (RF) technology in the 1920s opened the path to an energy gain of several tens of MeV per metre. Very-high-energy accelerators were constructed with RF technology, entering the GeV and finally the TeV energy scales at the Tevatron and the LHC. New collision schemes were developed, for example the mini-“beta squeeze” in the 1970s, advancing luminosity and collision rates by orders of magnitudes. The invention of stochastic cooling at CERN enabled the discovery of the W and Z bosons 40 years ago.

However, intrinsic technological and conceptual limits mean that the size and cost of RF-based particle accelerators are increasing as researchers seek higher beam energies. Colliders for particle physics have reached a

THE AUTHORS: Ralph Assmann, Massimo Ferrario, Carsten Welsch. University of Liverpool/INFN. CERN COURIER, MARCH 2012. 25

<https://www.eupraxia-facility.org/>

AWAKE made huge progress since Roadmap report

WP3.2: Proton-beam-driven experiments (Edda Gschwendtner, Patric Muggli)

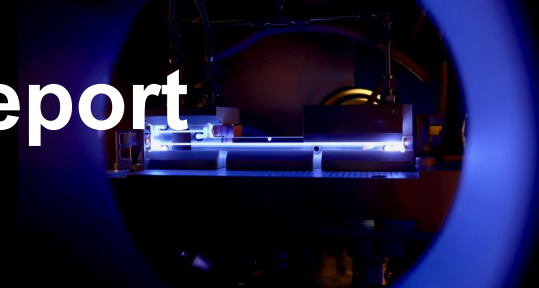

Achieved results:

Demonstration of increased electron energy gain using a density step in the self-modulator plasma source.

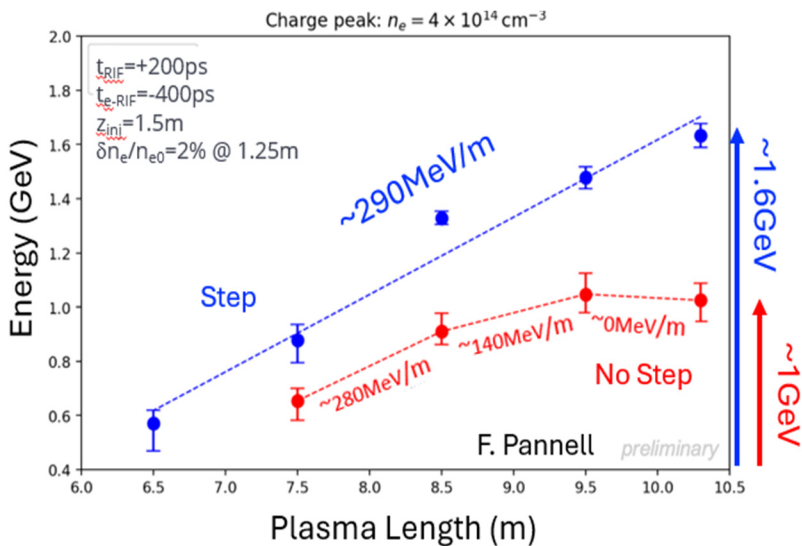

Accelerated electron energy at different plasma lengths

→ Expect 10 publications, 5 PhDs

Area extension (plus 100 m):



View into the 100m long CNGS target area, which will completely be dismantled in 2026 to install the upgraded AWAKE experiment. The current AWAKE experiment has already been removed.

Design of the AWAKE Experimental upgrade:

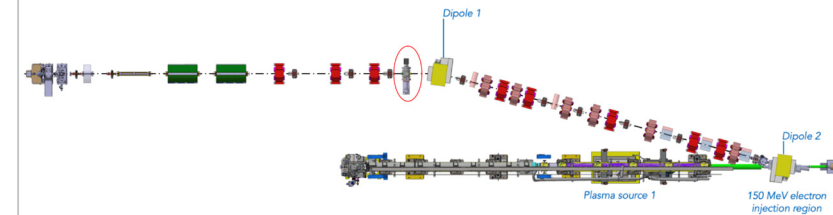

New witness electron beam system:
 150 MeV, 200 fs, 100 pC, $\sigma = 5.75 \mu\text{m}$
 → External injection!

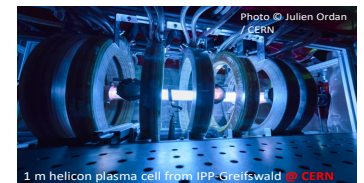
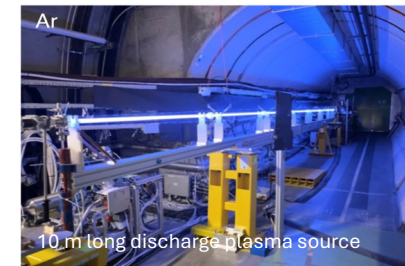

Scalable plasma source development (discharge and helicon plasma sources)

Muon Collider – Efficient at Highest Energies

Muon: $E_0 = 106 \text{ MeV}$ ($200 \times e^-$), $\tau_\mu = 2.2 \mu\text{s}$
 low SR, low beamstrahlung during collisions!
 stronger focusing with higher E is possible,
 thus L/P is increasing with energy

Beamstrahlung suppressed
 for muons!

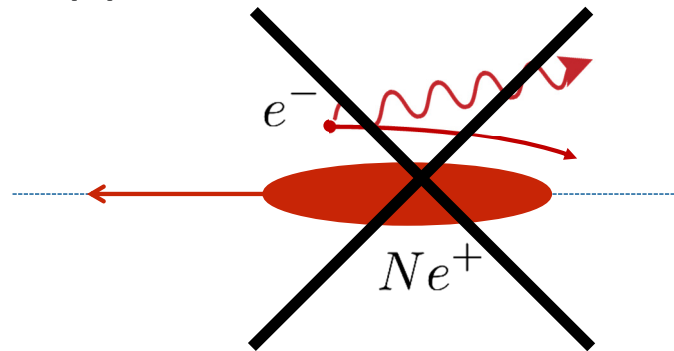

Muon collider:

$$\frac{\mathcal{L}}{P_{\text{beam}}} \propto \gamma$$

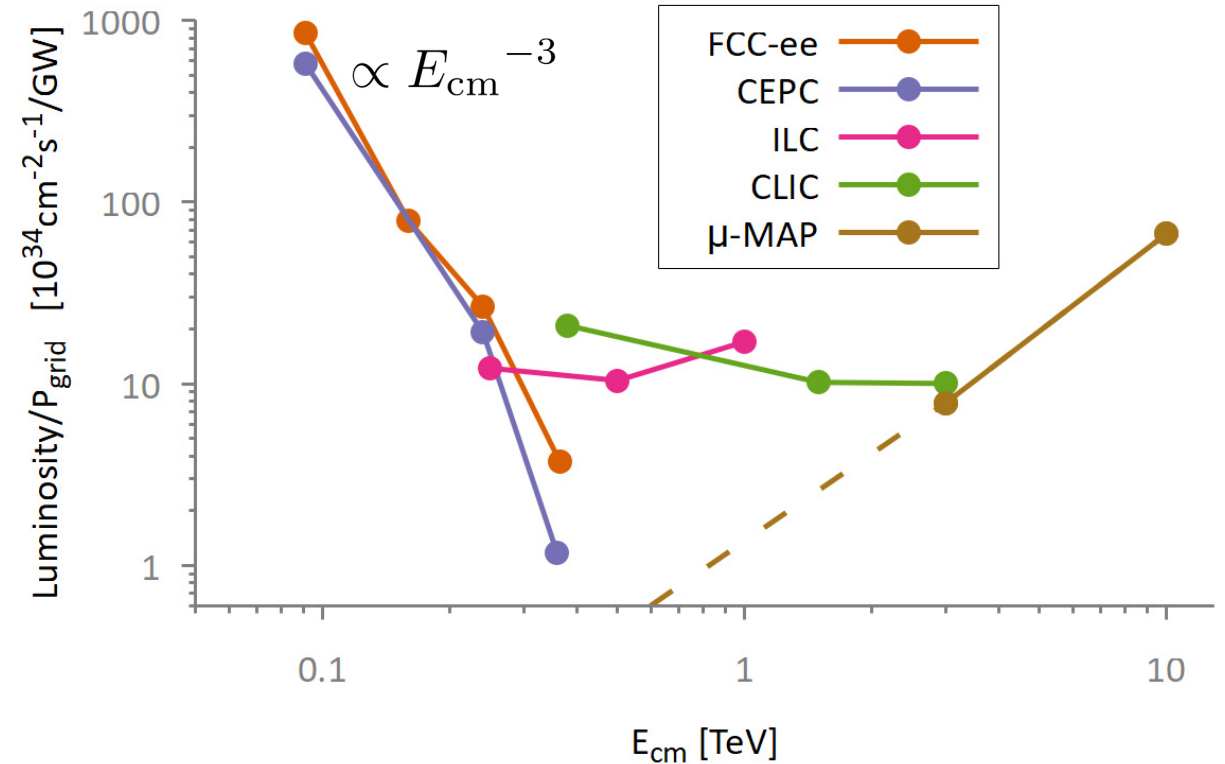

Lepton collisions at 3 or 10 TeV CM are in reach.

Muon Collider Focus



Short, intense proton bunch

Protons produce pions which decay into muons which are captured

Ionisation cooling of muon in matter

Acceleration to collision energy

Collision

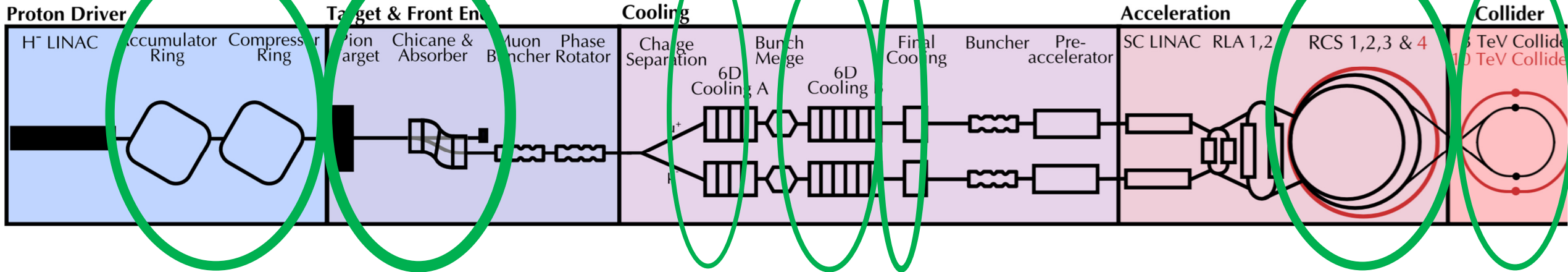

- Proton driver bunch compression

- Graphite target
- Target solenoid

- Muon cooling design
- 6D cooling solenoids
- 6D cooling RF cavities
- Final cooling solenoids

- Pulsed magnets and power converters
- RCS RF system

- Collider ring dipoles
- Final focus quadrupoles
- Machine-detector interface

Identified and prioritized with community
Critical lattice challenges
Critical Technology Elements (CTEs)

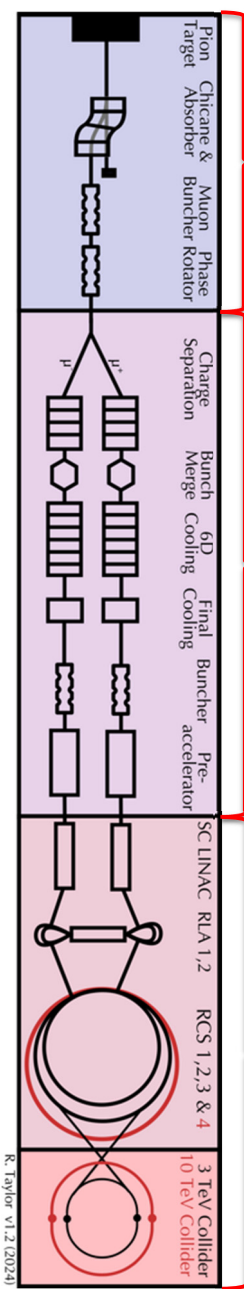

Target and capture solenoid

Muon beam cooling solenoids

Accelerator and collider magnets

23 solenoids: 20 T, 1.4 m bore

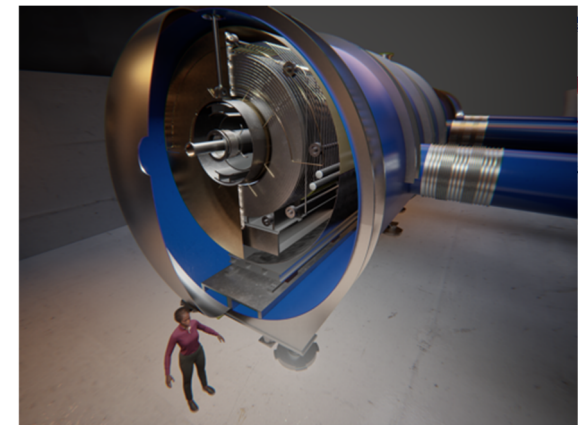
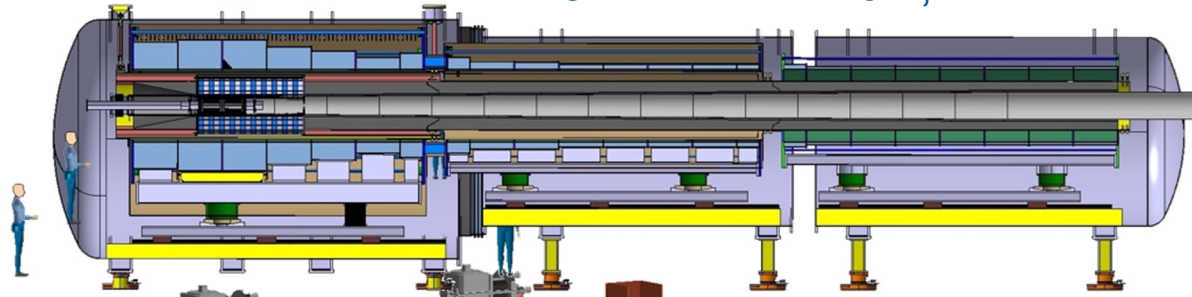

International Collider Corporation

3000 solenoids: 2 to 14 T, 90 mm to 1.5 m bore

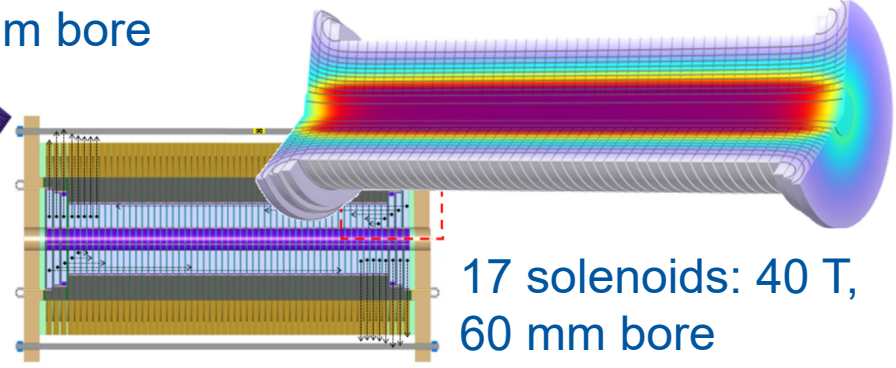
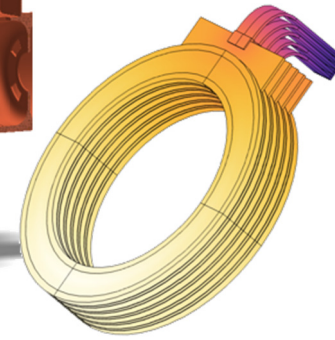
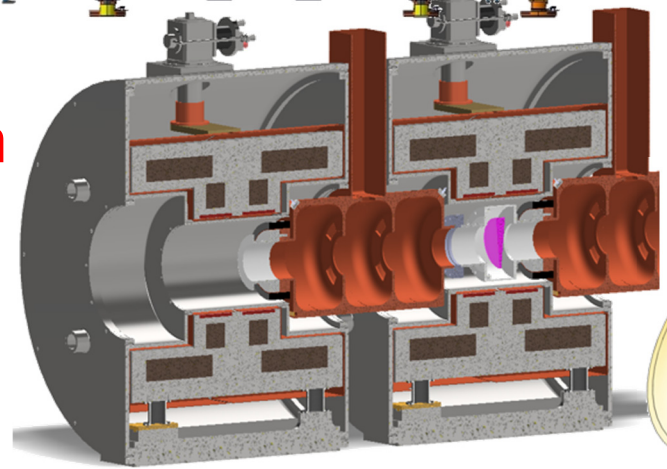

17 solenoids: 40 T, 60 mm bore

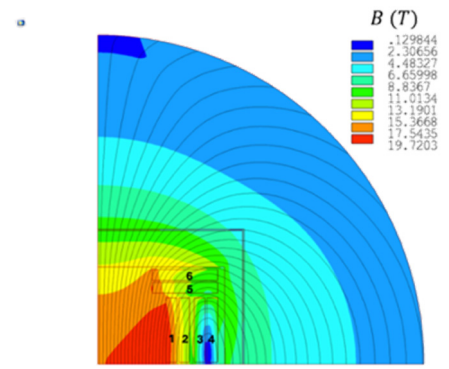
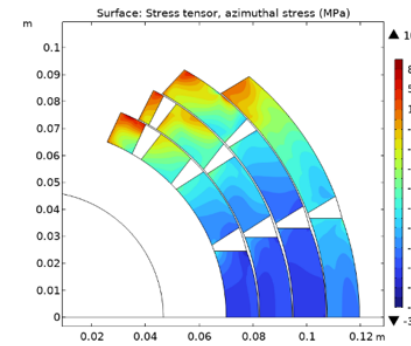
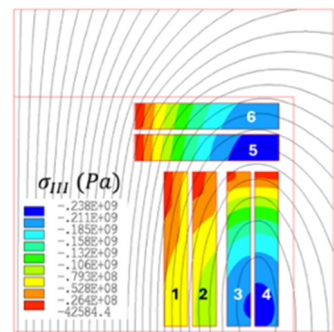
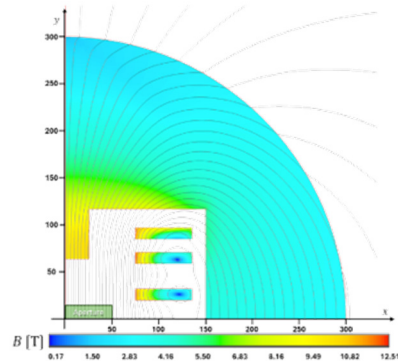

10 km 14 T, 140 mm bore dipoles

ERL vs Ring or Linear Collider

Ring beam circulates

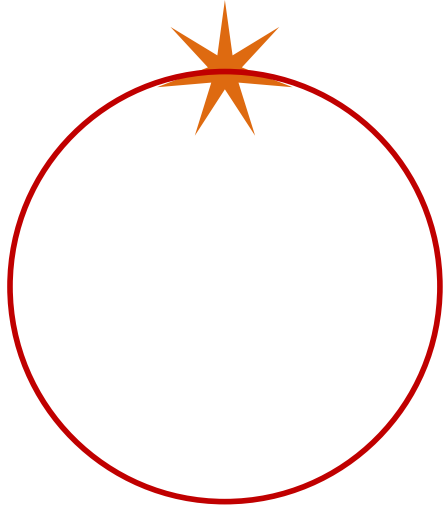

- beam (and energy) reused
- synchrotron radiation dominated
- equilibrium beamsizes → collision parameters limited

ERL power circulates

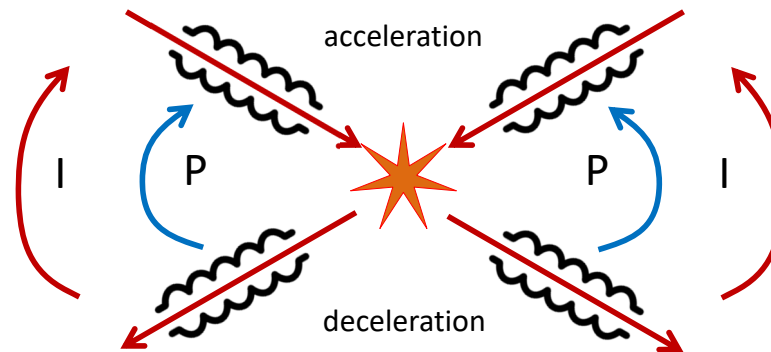

- power recirculated, beam recirc. at low E
- benefit from better collision parameters
- **high L per grid power, but higher investments & complexity**
- **main study today e-LHC, but also e+/e- possible**

Linear Collider high quality beam



- beam used only once
- no synchrotron radiation
- ambitious collision parameters possible (no ring dynamics)

ERL to enable high-power beams that would otherwise require one or more nuclear power plants

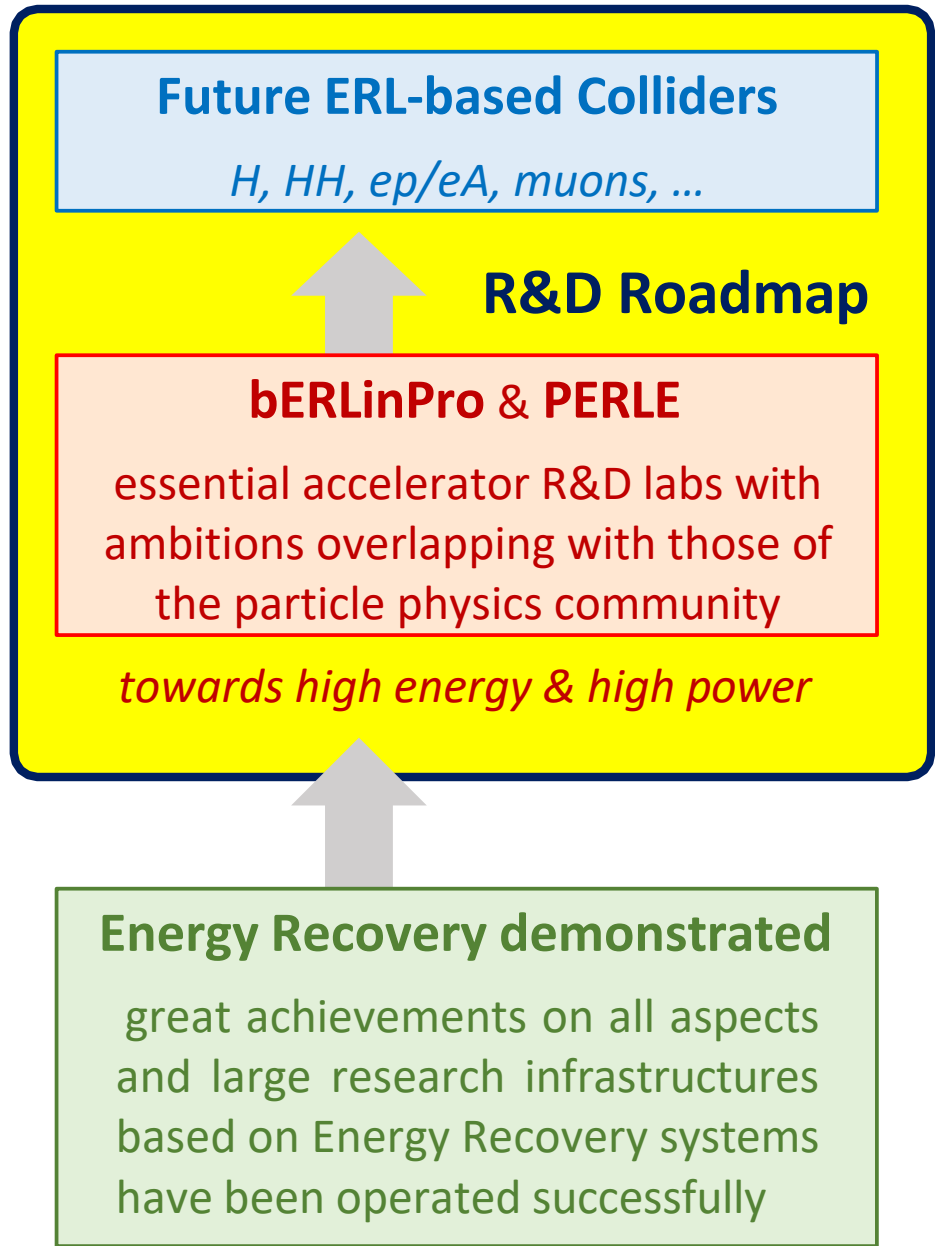
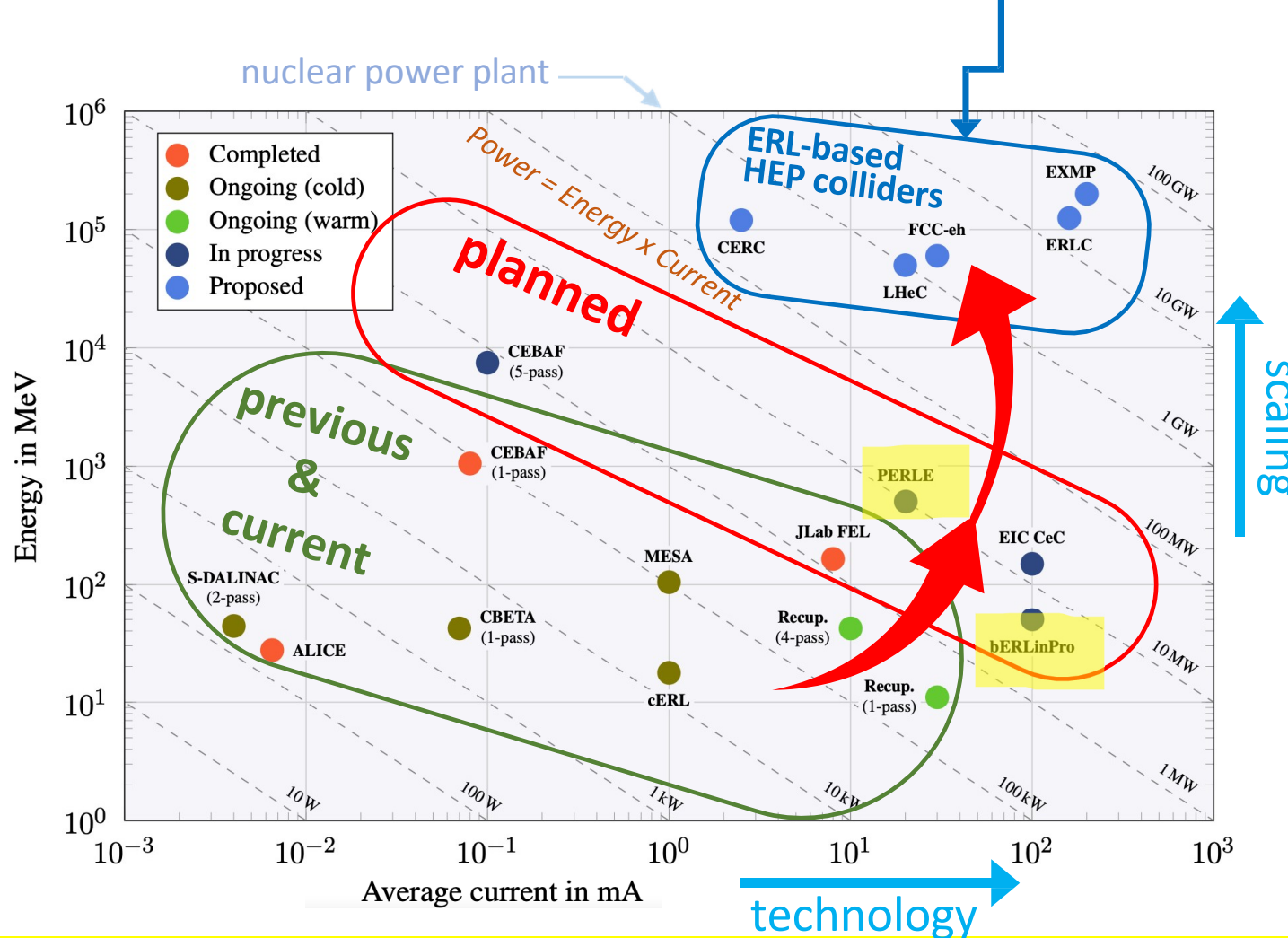

Energy Recovery Linacs (ERL): reaching higher luminosities with less power requirements

PERLE



Photocathodes Production Facility (PPF)



Photocathode Laser room

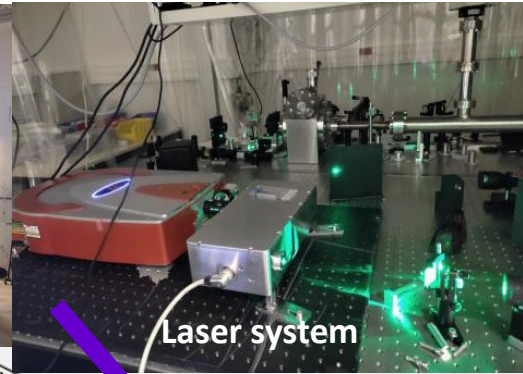

Laser system

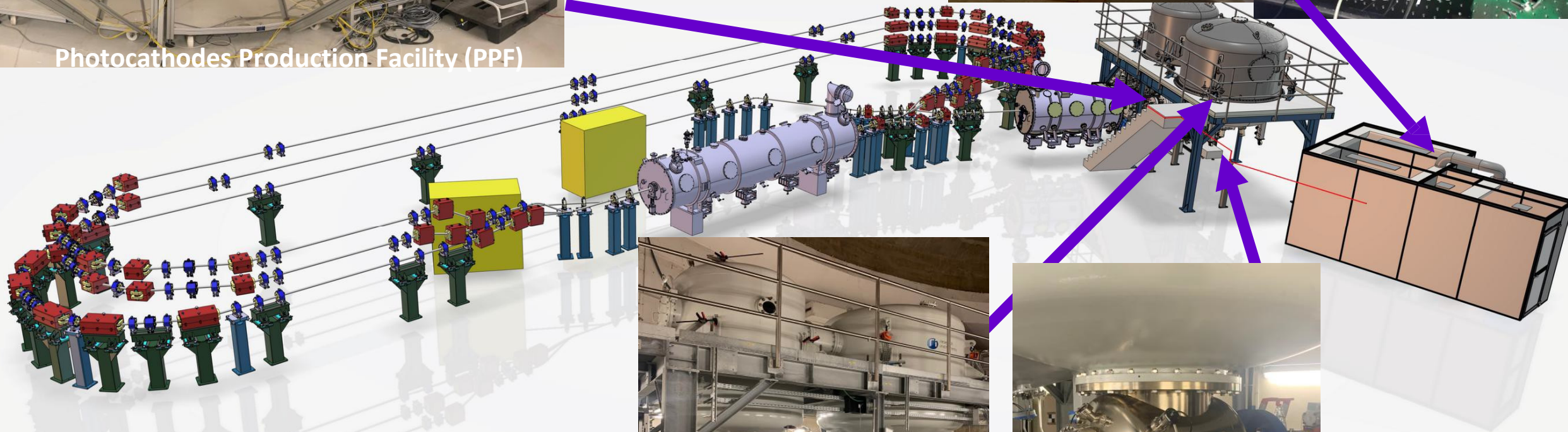

DC Gun & HV system



DC Gun

PERLE @ DIS2026 -
Bologna Mai-2026
A.Stocchi et al

**PERLE: multi-turn ERL based on SRF technology
(3-turns)**

PERLE – Powerful Energy Recovery Linac for Experiments
[CDR: *J.Phys.G* 45 (2018) 6, 065003]

From Executive Summary: *The LDG Sustainability WG report outlines the reference framework of best practices & standards for assessing and guiding a sustainable development of large-scale facilities for future accelerators:*

- ✓ **Landscape of comprehensive sustainability analysis (best practices adopted by RI's)**
- ✓ **Basis of LCA - Status & recommendations for developing analysis for accelerator infrastructures, components and systems**
- ✓ **Environmental impact of Large RI's during construction, operation & decommissioning phases**
- ✓ **Mitigation and Compensation Measures**
 - **Targets future accelerators & particle physics projects, relevant for other research infrastructures**
 - **Promotes transparent, open discussions within research communities, to adequately convey the information to a broader set of stakeholders**
 - **Establishing "Guidelines" is the responsibility of each RI, based on national & local legislations**

Sustainability Assessment of Future Accelerators

C. Bloise^a, E. Cennini^b, J. Gutleber^b, W. Kaabi^c, A. Klumpp^d, P. Koppenburg^e, Y. Li^f, B. List^d, R. Losito^b, B. Mandelli^b, E. A. Nanni^g, N. Neufeld^b, T. Schoerner-Sadenius^d, B. Shepherd^h, V. Shiltsevⁱ, S. Stapnes^b, M. Titov^j, L. Ulrici^d, H. Wakeling^k

^aLNF-INFN, Frascati, Italy ^bCERN, Geneva, Switzerland ^cIJCLab, Orsay, France
^dDESY, Hamburg, Germany ^eNIKHEF, Amsterdam, The Netherlands
^fIHEP, Beijing, China ^gSLAC, Menlo Park, CA, USA
^hASTeC, Daresbury Laboratory, STFC, UK ⁱNorthern Illinois University, DeKalb, IL, USA
^jIRFU, CEA-Saclay, Gif-sur-Yvette, France
^kJohn Adams Institute, University of Oxford, Oxford, UK

Abstract

The Large Particle Physics Laboratory Directors Group (LDG) established the Working Group (WG) on the Sustainability Assessment of Future Accelerators in 2024 with the mandate to develop guidelines and a list of key parameters for the assessment of the sustainability of future accelerators in particle physics. While focused on accelerator projects, much of the work will also be relevant to other present and upcoming research infrastructures. The development and continuous update of such a framework aim to enable a coherent communication amongst scientists and adequately convey the information to a broader set of stakeholders. This document outlines the key findings and recommendations of the LDG Sustainability WG and provides a summary of current best practices aimed at enabling sustainable accelerator-based research

Approved by LDG in Sep. 2025:

<http://arxiv.org/abs/2509.11705>

Shorter report version in new Springer EPJ Research Infrastructures

renewed mandat 2025:



LARGE PARTICLE PHYSICS LABORATORY DIRECTORS GROUP

Second Mandate for the panel on sustainability, November 2025

The first mandate for the LDG sustainability panel was focused on developing guidelines and a minimum set of key indicators pertaining to the methodology and scope of the reporting of sustainability aspects for future HEP projects. With the renewed mandate the aim is to take the panel work one step further, towards formulating best practices for constructing and operating sustainable accelerator driven research infrastructures. The suggestions should be based on an assessment of the improvement potential and the cost-benefit ratio for the various sustainability related areas of concern. The LDG panel should not do its own research, but can trigger collaborations, help avoiding parallel activities and help to focus efforts.

the main tasks:

1. Prepare an overview on sustainability related expertise in the LDG laboratories and suggest networking activities among the labs and with CERN. Explore ways to synchronize the efforts of the LDG panel with the workshop series "Sustainability of HEP".
2. Develop a set of best practices to improve sustainability for accelerator driven RIs with ranked priorities. These should be specific and, if possible, substantiated by instances implemented in operating facilities.
3. Using an appropriate metrics, assess which of the aspects critical for sustainability of RIs in the field of HEP have a realistic potential for improvement. Take into account the cost/benefit ratio of possible investments.
4. While some possible measures are well understood, R&D may be required in other areas. Recommend the top five R&D activities for those aspects that show promise in terms of energy efficiency and sustainability and that should be prioritised.

possible particular topics to be addressed in addition:

- Life cycle assessment of accelerator components needed in large numbers or containing critical/high CO2 footprint materials will be important in the future. Assess which types of components are particularly relevant for future colliders. Contribute to establishing best practices for longevity and reparability of components.
- Assessment of dynamic operation of infrastructures, i.e. preferred operation when excess energy from fluctuating sustainable sources is available on the grid.
- Detector gases is a big issue. Is this sufficiently addressed in DRD panels, and do we use collaboration across labs adequately?
- For collider facilities with large electricity consumption, the option of installing co-generation power plants, such as gas turbines or possible Small Modular Reactors (SMR) can be assessed. Expertise of the technical groups of large labs should be utilized.
- Full sustainability assessment gets quickly very complex, for example if delivery chains of materials are fully analysed. The panel may develop guidelines up to which degree of detail such studies should be made for RIs in the HEP sector.

The panel provides input for the renewal of the LDG accelerator roadmap at the end of 2026 by suggesting few top ranked sustainability related R&D topics. The panel's work should conclude in February 2028 with a concise report on its findings and results (10..20 pages suggested). Depending on these results and on developments in the accelerator roadmap, the mandate may be renewed.

- ▶ **High Field Magnets and RF Systems form the building blocks for future facilities and technology R&D is focused on those, in particular on superconducting technologies.**
- ▶ **advanced concepts are promising for long term collider development:**
 - ▶ **plasma acceleration → small footprint**
 - ▶ **muon collider → highest lepton collision energies**
 - ▶ **energy recovery linacs → most energy efficient**
- ▶ **energy efficiency and sustainability are key and have a high relevance for public acceptance of particle physics RIs**
- ▶ **significant research is needed → the LDG accelerator roadmap will be updated in 2026 and aligned with the priorities set by ESPPU'26**