



# Acceleration Technology and Sustainability

**Mike Seidel**

Paul Scherrer Institute and EPFL, Switzerland

IPAC'26, Student Tutorials

May 16, 2026

Deauville

**Sustainability = Meeting the needs of the present  
without compromising the ability of future generations.**

(one of many debated formulations)

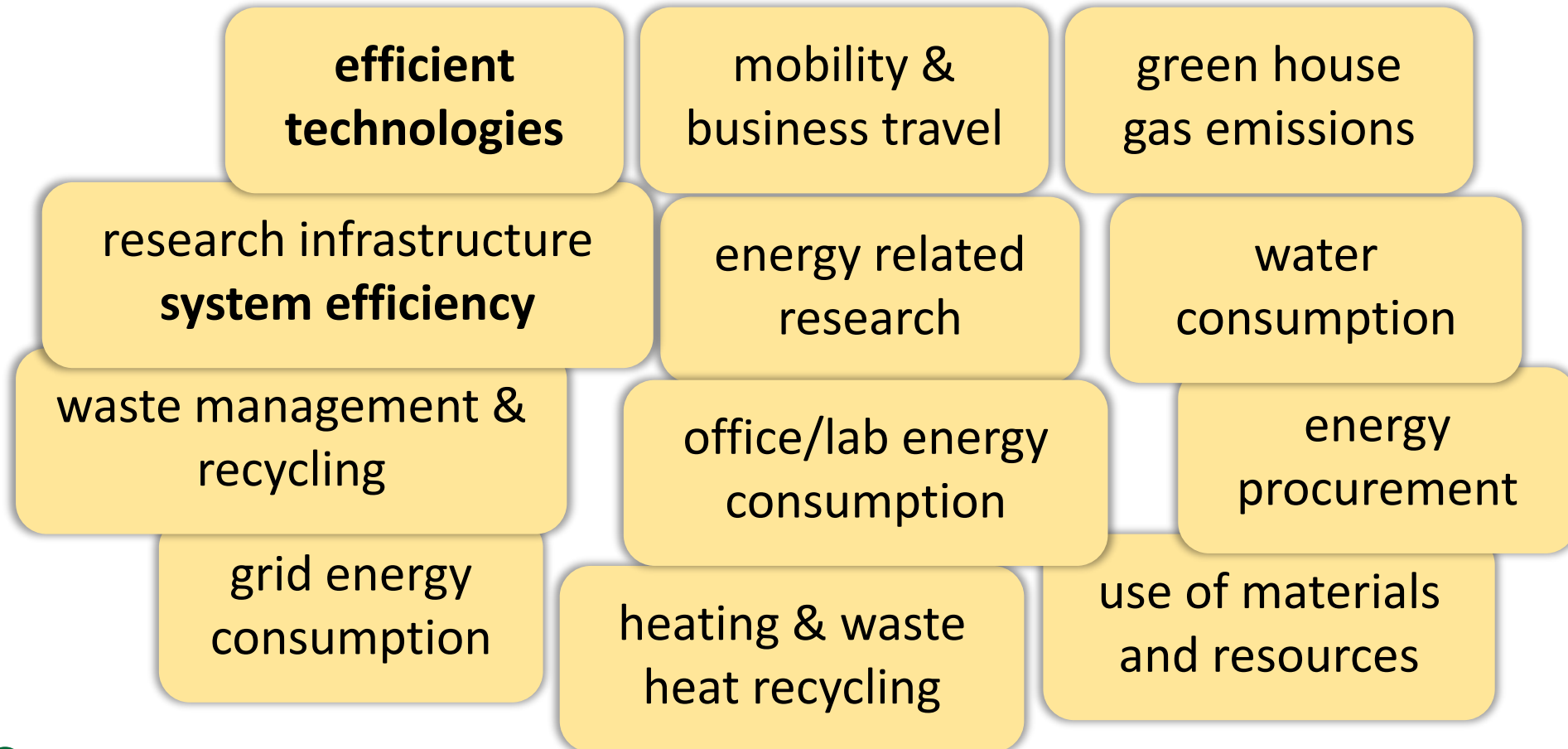

# Energy Consumption - Motivation

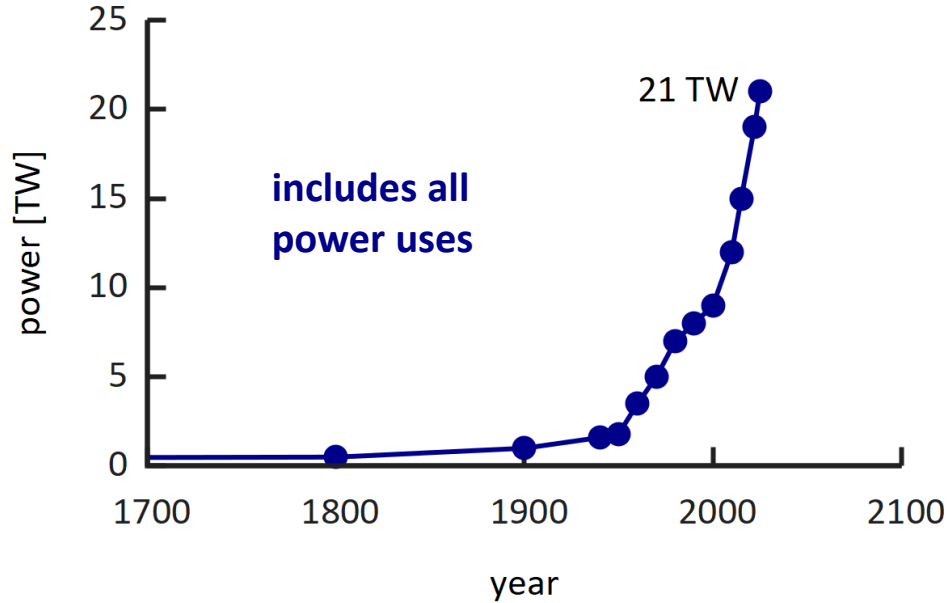

The world energy consumption has been continuously rising, reaching ca **21 TW** today.

As a science community we rather want to contribute to solutions and not be part of the problem.

example from nature:  
the Earth-Moon system dissipates **3.8 TW** power from the rotation energy of earth

[Williams, Boggs, 2016]

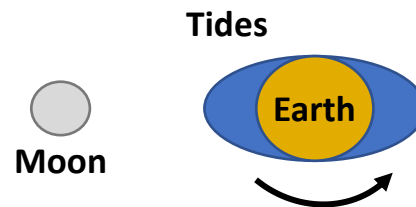

School Strike  
for Climate  
Wikipedia



# Community Activities on Sustainability

**2014-17: EUCARD-2**, WP Energy Efficient Accelerator Technologies

<https://www.psi.ch/enefficient>

**2017-21: ARIES**, Work Package Efficient Energy Management

<https://www.psi.ch/aries-eem>

**2021-25: I.FAST**, Work Package Sustainable Concepts

<https://www.psi.ch/scat>

**2024- : LDG**, Sustainability Working Group

<https://ldg.web.cern.ch/working-groups/sustainability-assessment-of-accelerators>



Enhanced European Coordination for Accelerator  
Research & Development



ACCELERATOR RESEARCH AND  
INNOVATION FOR EUROPEAN  
SCIENCE AND SOCIETY



Innovation Fostering in Accelerator Science  
and Technology

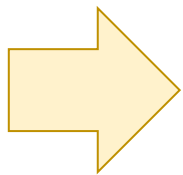

- ICFA panel on sustainable accelerators, chair: Thomas Roser (BNL)
- <https://icfa.hep.net/icfa-panel-on-sustainable-accelerators-and-colliders/>



# Accelerator driven Research Infrastructures (RI)

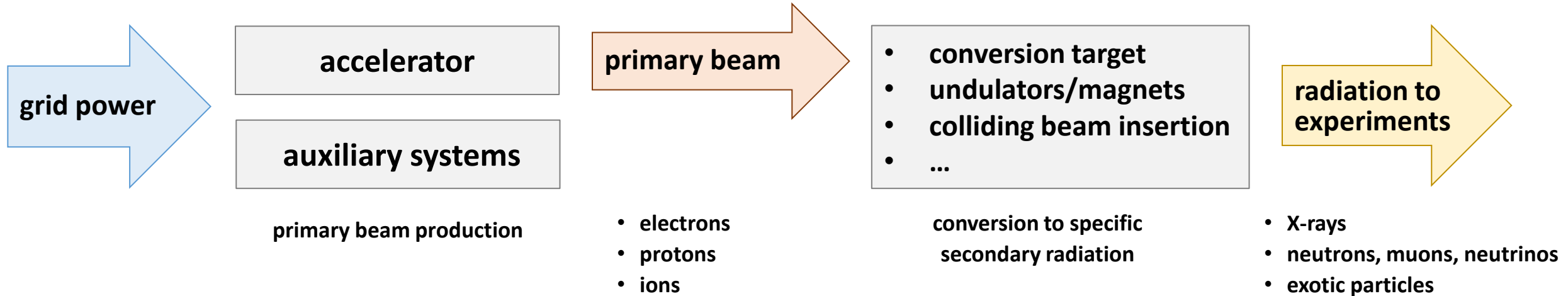

high level goal:

Science output per grid power, per operating/investment cost.



# Accelerator Concepts and Technologies

[with emphasize on energy efficiency]

**concepts, RI's**

**Proton Drivers with high intensity applications**

**Synchrotron Light Sources and FELs**

**Particle Colliders**

**Resonators and high Power RF Systems**

**Accelerator Magnets and Power Supplies**

**technologies**

**Cryogenic Systems**

**Component Cooling, Air Conditioning, Vacuum, Instrumentation ... and other aux. systems**



# Efficient Accelerator Technologies

# Accelerator Magnets with Permanent Magnet Material

Dipole and Quad for SLS2.0, S.Sanfilippo et al (PSI)

## permanent magnets:

- + extremely compact → low emittance lattices
- + no power consumption
- + no cooling, thus no heat introduced, no vibrations from cooling loop
- field tuning difficult
- use of rare earth materials

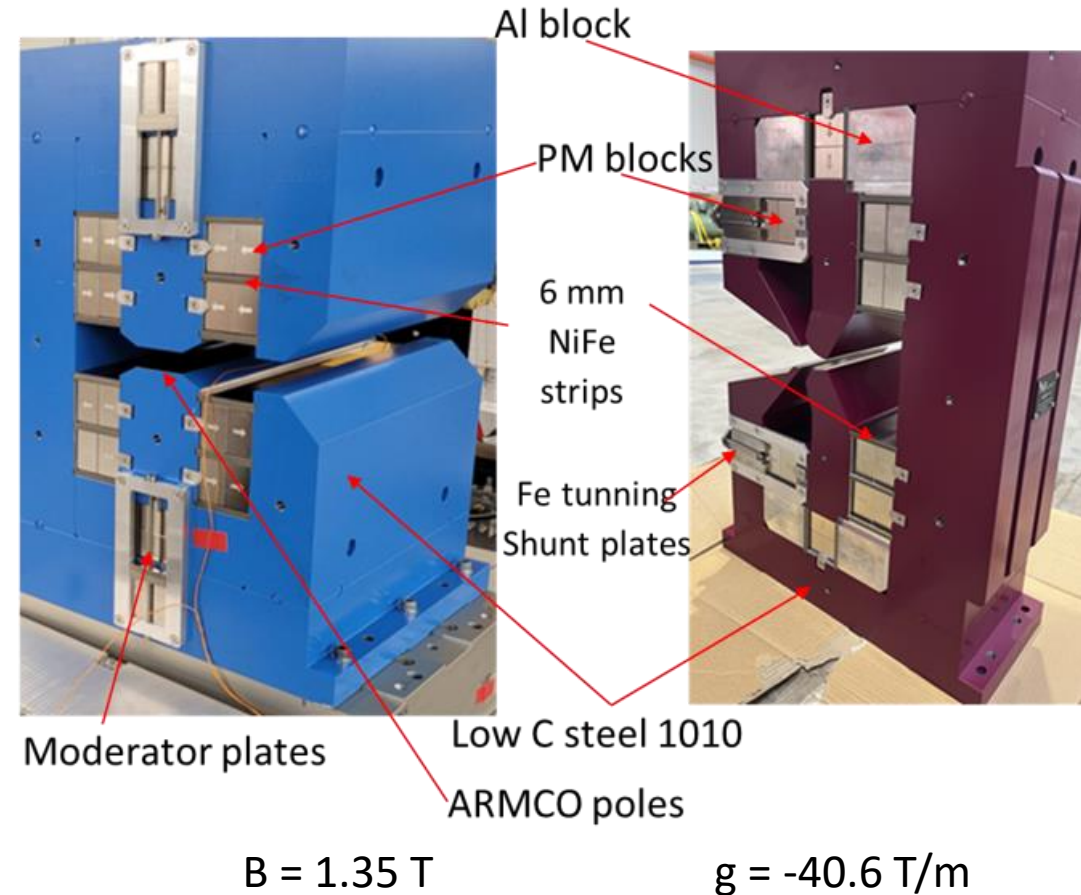

# Accelerator Magnets with High Temperature Superconductor Coils

## magnets with High Temperature Superconductor (HTS) coils:

- + medium fields for all applications (high fields in block config.)
- + ReBCO and Bi-2212 materials are studied
- + no ohmic losses, can replace power hungry large aperture dipoles/quads
- + cryogen free conduction-cooling possible (no He)
- + much improved cryogenic efficiency at elevated temperatures (e.g. 4.5K...15K instead 2K)
- today expensive materials
- field ramping and field quality difficult (wide tapes)

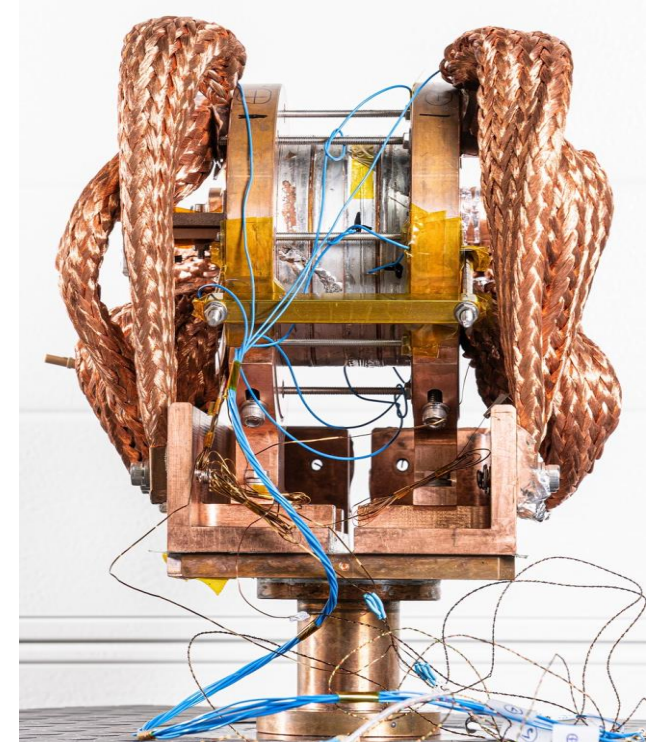

solenoid test magnet, 18T @ 12K  
PSI/CHART, B.Auchmann et al



# Efficient RF Power Sources

- **Klystrons**,  $\eta > 70\%$  within reach  
e.g. CLIC two stage multi-beam klystron, J.Cai, I.Syratchev, IEEE Trans, 2020
- **Magnetron**, R&D at various groups,  $\eta = 60-80\%$  within reach  
e.g. Wang et al, J-Lab, IPAC 2019; A.Dexter, Lancaster U., LINAC-2014; B.Chase, Fermilab, JINST-2015
- **Solid state amplifiers (SSA)** at various groups,  $\eta = 60-90\%$  depending of freq.

3362

IEEE TRANSACTIONS ON ELECTRON DEVICES, VOL. 67, NO. 8, AUGUST 2020



## Modeling and Technical Design Study of Two-Stage Multibeam Klystron for CLIC

Jinchi Cai<sup>✉</sup> and Igor Syratchev<sup>✉</sup>

Example: study 1GHz for CLIC drive beam; 6 cavities, 30 beamlets; 25+140kV;  $\eta_{\text{sat}} = 82\%$

IEEE TRANSACTIONS ON MICROWAVE THEORY AND TECHNIQUES, VOL. 70, NO. 2, FEBRUARY 2022

1401

## Kilowatt Power Amplifier With Improved Power Back-Off Efficiency for Cyclotron Application

Renbin Tong<sup>✉</sup>, Olof Bengtsson<sup>✉</sup>, *Senior Member, IEEE*, Jörgen Olsson<sup>✉</sup>, *Senior Member, IEEE*,  
Andreas Bäcklund, and Dragos Dancila<sup>✉</sup>

Example: SSA for Isotope production Cyclotron, 98.5MHz, 12x1kW units,  $\eta_D = 93\%$  (90% with regulation overhead)  
Uppsala group, WP in I.FAST program

**I.FAST efficient RF workshop, July 23-25, 2025, Toledo:**

<https://indico.cern.ch/event/1407353/>



# Technology R&D: Superconducting RF at higher temperature

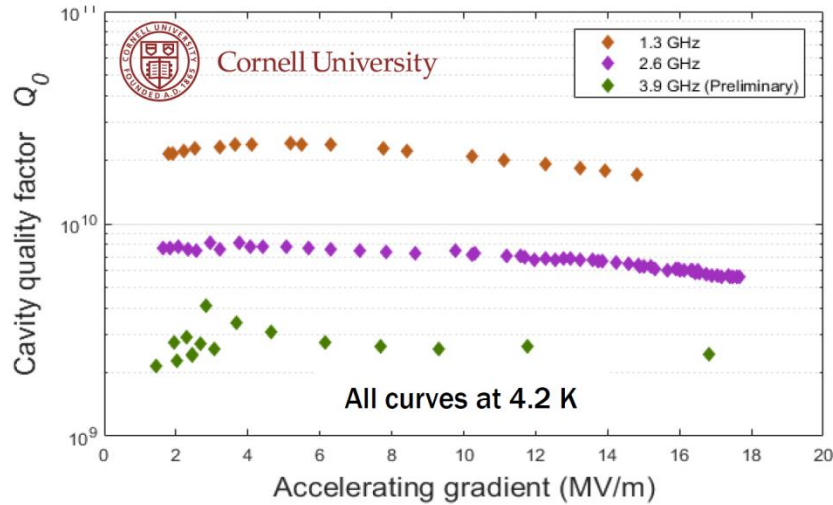

- promising R&D: Nb<sub>3</sub>Sn coated cavities at Cornell
- 4.2 vs. 2.0K → efficiency

[M.Liepe, Cornell, IPAC'19]

Cornell, FERMILAB  
→ simplicity, cost, efficiency, smaller size

S Posen et al 2021 Supercond. Sci. Technol. 34 025007  
record cw gradient in Nb<sub>3</sub>Sn-coated, E<sub>acc</sub> = 24 MV/m

**SMART recipe leads to a T<sub>c</sub> of 15.4 K** on Nb-samples coated with 15 / 25 nm of AlN / NbTiN

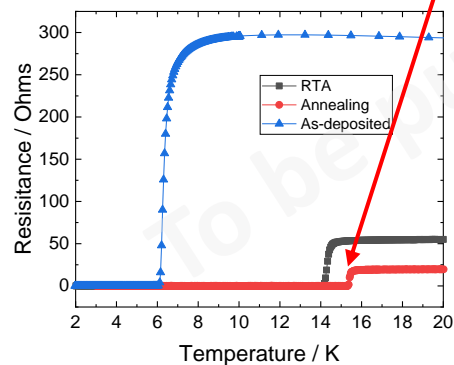

DESY, Hamburg U.

aim for sustained SRF accelerator technology

*10y Goal: >70 MV/m with a Q<sub>0</sub> of 1x10<sup>10</sup> and at 4K*

*contact: M.Wenskat, DESY*

G. Deyu et al., „Al<sub>2</sub>O<sub>3</sub> coating of Superconducting Niobium Cavities with thermal ALD“, in preparation



# Proton Driver Accelerators

or: Best attainable Grid-to-Beam efficiency?

# Comparison: Megawatt p-Drivers



Workshop: Efficiency of Proton Driver Accelerators, 2016, PSI  
<https://indico.psi.ch/event/3848/>

Yakovlev, FNAL, invited talk, IPAC 2017

FRXCBI

Proceedings of IPAC2017, Copenhagen, Denmark

## THE ENERGY EFFICIENCY OF HIGH INTENSITY PROTON DRIVER CONCEPTS\*

J. K. Grillenberger, Paul Scherrer Institut, 5232 Villigen, Switzerland,  
 S-H. Kim, Oak Ridge National Laboratory, Oak Ridge, TN 37831, USA  
 M. Yoshii, KEK and JAEA J-PARC Center, 2-4 Shirakata-Shirane, Tokai, Ibaraki 319-1195, Japan  
 M. Seidel, Paul Scherrer Institut, 5232 Villigen, Switzerland  
 V.P. Yakovlev<sup>†</sup>, Fermi National Accelerator Laboratory, Batavia, IL 60510, USA

Megawatt class facilities  
operating today:

optimized for application,  
not efficiency

facility	accelerator type	Economy	Energy Reach	Power Reach	operational complexity	grid-to-beam Efficiency
SNS	superconducting linac	--	++	++	++	<b>9%</b>
J-PARC	rapid cycling synchrotron	++	++	-	-	<b>3%</b>
PSI	isochronous cyclotron	+	--	+	-	<b>18%</b>



# Superconducting Linac : High Efficiency Potential

example: PIP-II design of Fermilab

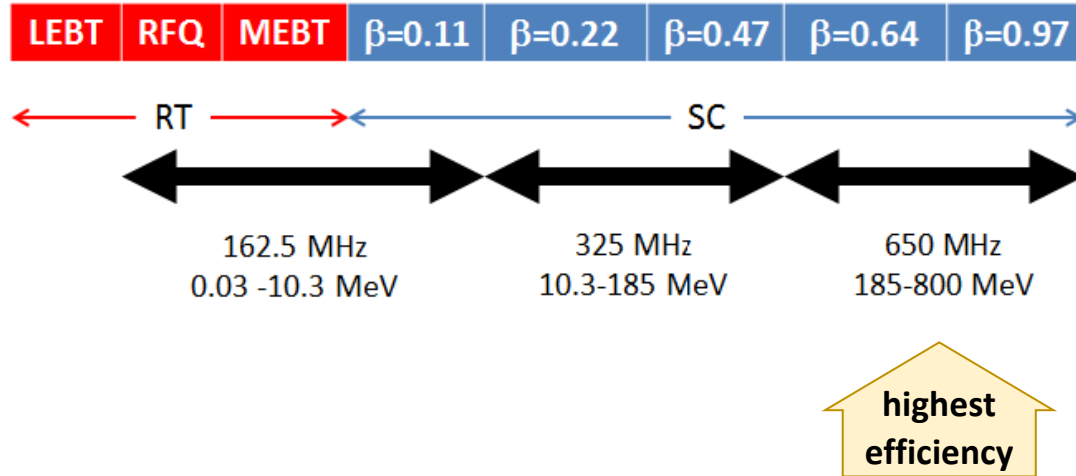

## PIP-II base parameters:

- **H<sup>-</sup>, 800MeV, 2.0mA**, part of Fermilab complex
- aim: neutrino production (1MW @ 60..120GeV)
- CW operation as upgrade path

not efficient in pulsed operation:

operating regime	avg. RF power	cryogenic power	avg. beam power	grid-to-beam Efficiency
PIP-II pulsed operation	<b>1.44MW</b>	<b>1.19MW</b>	<b>17.6kW</b>	<b>0.7%</b>
PIP-II CW operation	<b>9.10MW</b>	<b>1.83MW</b>	<b>1.60MW</b>	<b>15%</b>

[from presentation B.Chase, Y.Yakovlev, 2018]

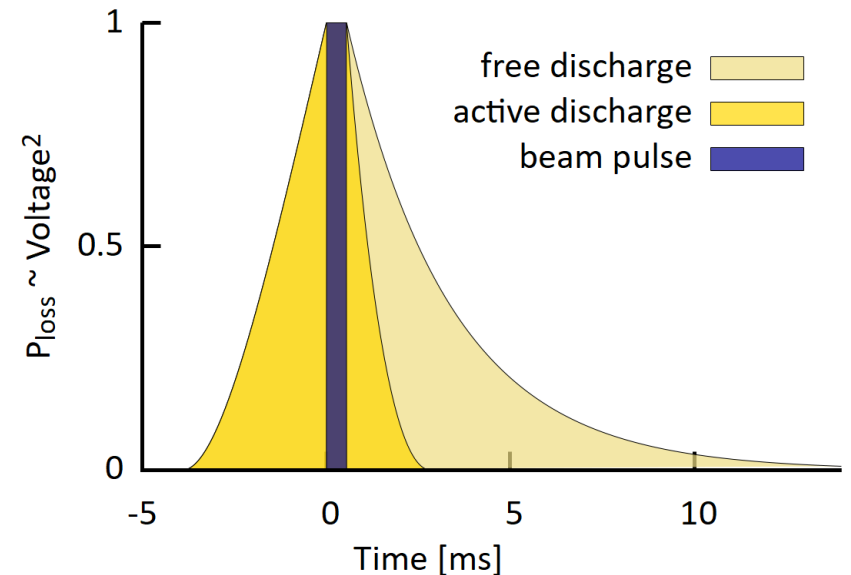

# Low Loss Superconducting Resonators

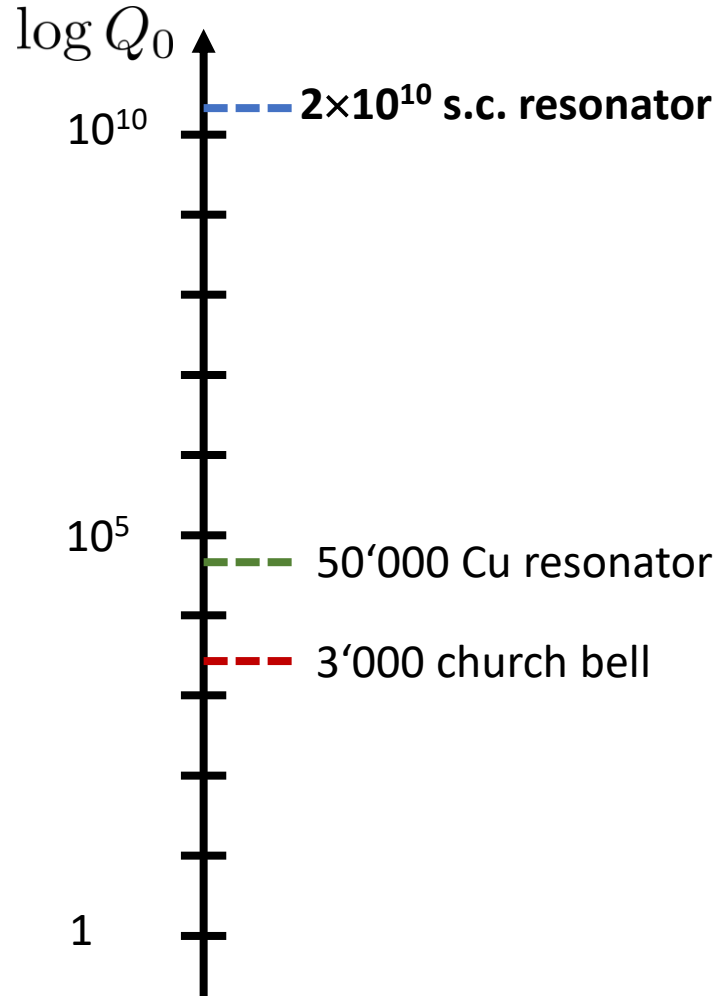

$Q_0$  = quality factor

→ e-folding decay and resonance width

dissipated power:

$$P_{\text{dissip}} = \frac{U_a^2}{\left(\frac{R}{Q}\right) Q_0}$$

**example:**

$$U_a = 20\text{MV}, (R/Q) = 609\Omega, Q_0 = 2 \times 10^{10}, I_b = 2\text{mA}$$

$$\rightarrow P_{\text{dissip}} = 33\text{ W}$$

$$\rightarrow P_{\text{beam}} = 40.000\text{ W}$$

high Q resonators, 1.3GHz, 2K, FNAL  
[A.Grassellino, A.Romanenko et al, 2013]

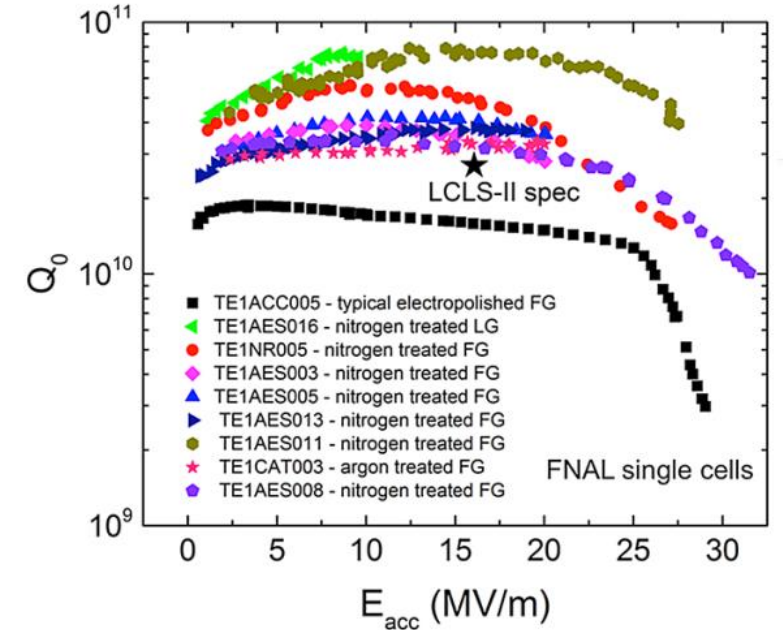

but: cryogenic efficiency!



# Cryogenic Efficiency

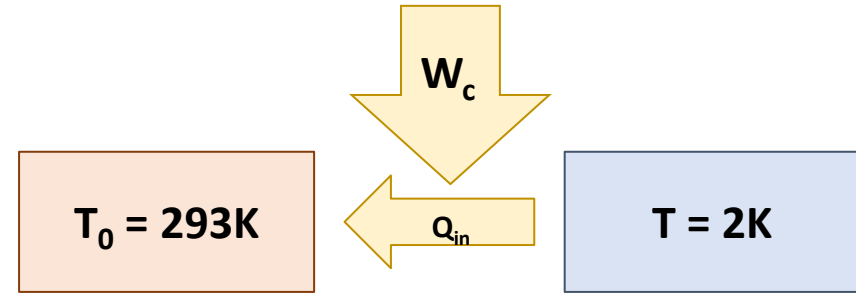
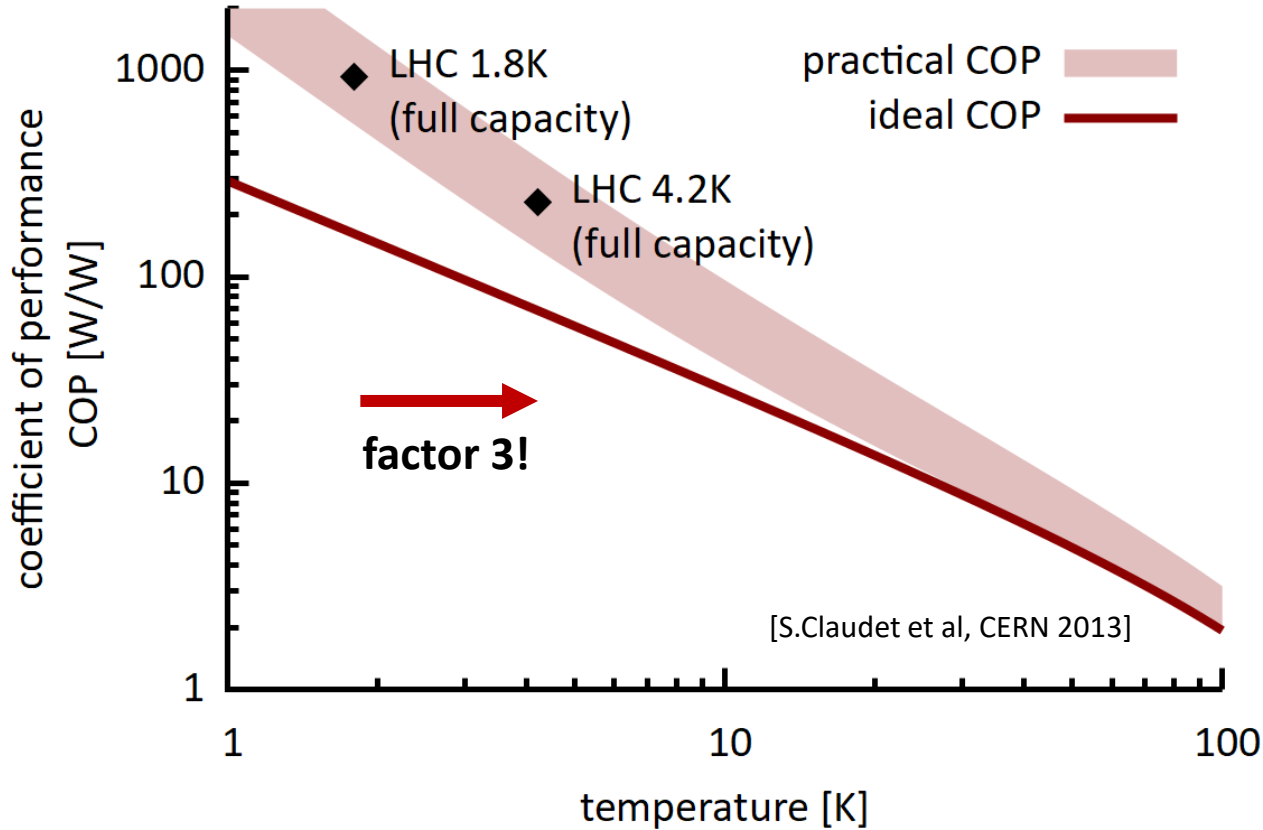

best possible coefficient of performance (COP):

$$\text{COP} = \left( \frac{W_c}{Q_{in}} \right)_{\text{Carnot}} = \frac{T_0 - T}{T}, \quad T_0 = 293 \text{ K}$$

$W_c$  = amount of work required to remove heat  $Q_{in}$  at cold temperature  $T$

$$P_{\text{cryo}} = \text{COP} \cdot P_{\text{dissip}}$$



# Powerflow s.c. Linac – Minimum System Example for a Single Cavity

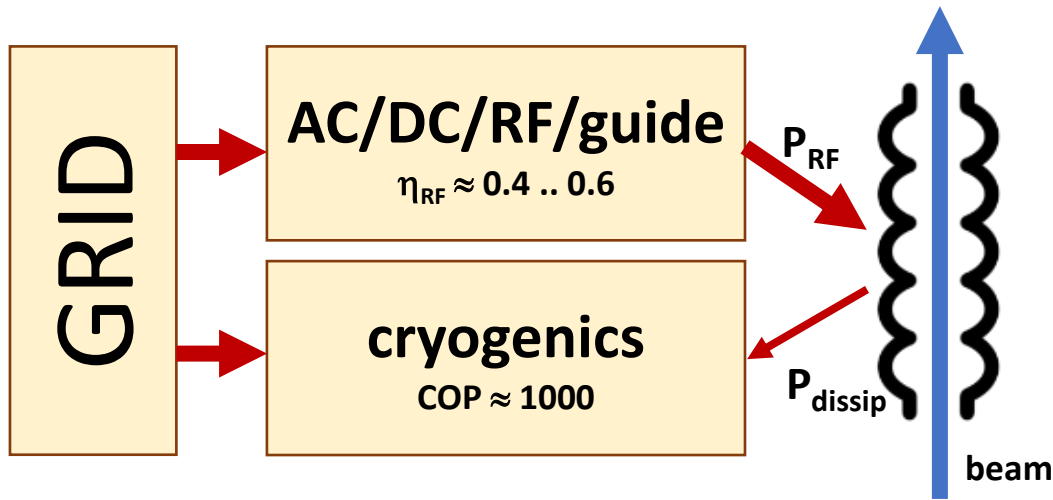

power balance:

$$P_{\text{grid}} = P_{\text{cryo}} + P_{\text{RF}}$$

$$= \text{COP} \cdot P_{\text{dissip}} + \frac{1}{\eta_{\text{RF}}} \Delta P_{\text{beam}}$$

$$\eta_{\text{total}} = \frac{\Delta P_{\text{beam}}}{P_{\text{grid}}}$$

considered:

- one 650MHz cavity
- $U_a = 20\text{MV}$
- $l = 1.1\text{m}$

ignored: cavity detuning,  
 $\beta < 1$ , regulation overhead,  
 aux. systems ...

regime	$I_b$ [mA]	$Q_0$	$\eta_{\text{RF}}$	$\Delta P_{\text{beam}}$ [kW]	grid-to-beam Efficiency
TDR, CW	2.0	$2 \cdot 10^{10}$	0.44	40.0 kW	30%
high Q	2.0	$3 \cdot 10^{10}$	0.44	40.0 kW	33%
high current	4.0	$3 \cdot 10^{10}$	0.65	80.0 kW	50%

extrapolation



# Light Sources

# Synchrotron Light Sources and Free Electron Lasers

- over the history ring light sources have improved the brilliance by more than 10 orders of magnitude, the last step is made using **multi bend achromat lattices** and miniaturization using permanent magnets
- **power consumption** of ring light sources is in the range of a few Megawatt and **often not a critical factor**; however, s.c. FELs might use O(20MW)
- the production of tailored radiation – spectral distribution, coherence, ultrashort pulses etc. is in the focus today

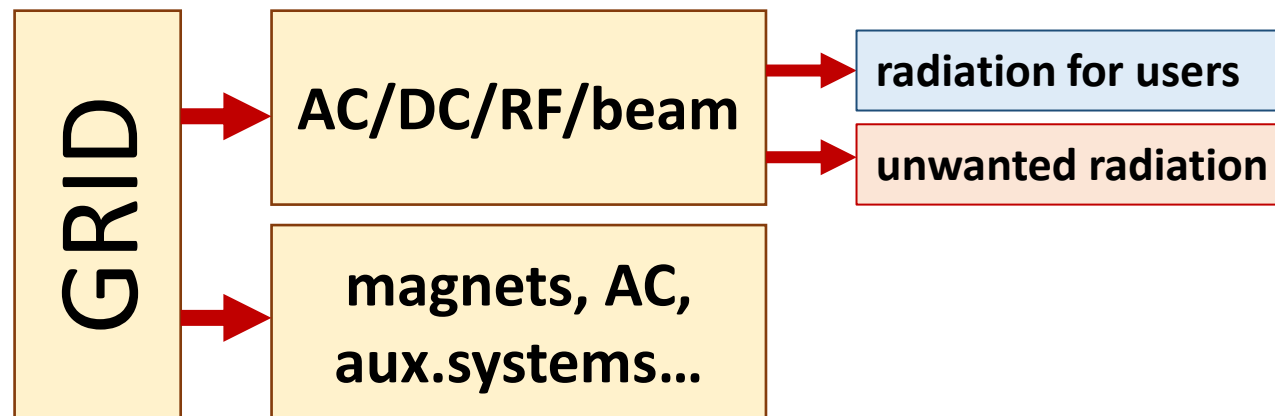
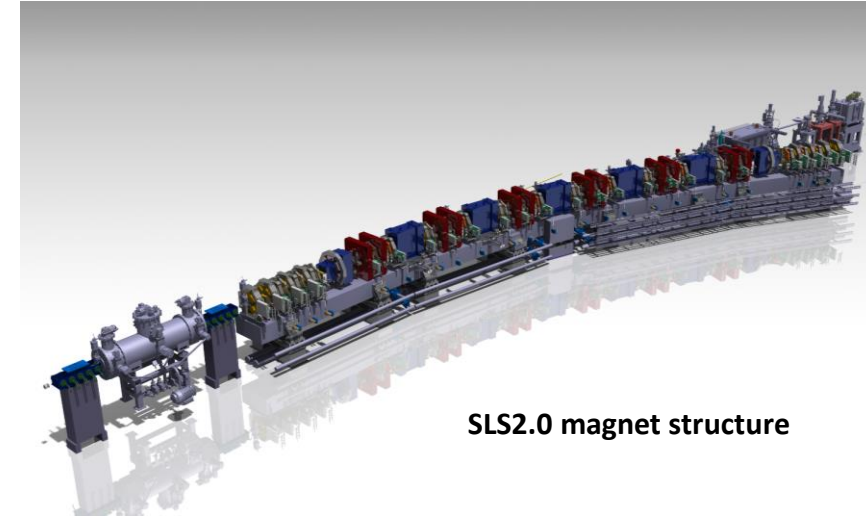

possible efficiency  
measure:

$$\eta_{\text{total}} = \frac{P_{\gamma, \text{users}}}{P_{\text{grid}}}$$



# Example Swiss Light Source SLS and its Upgrade

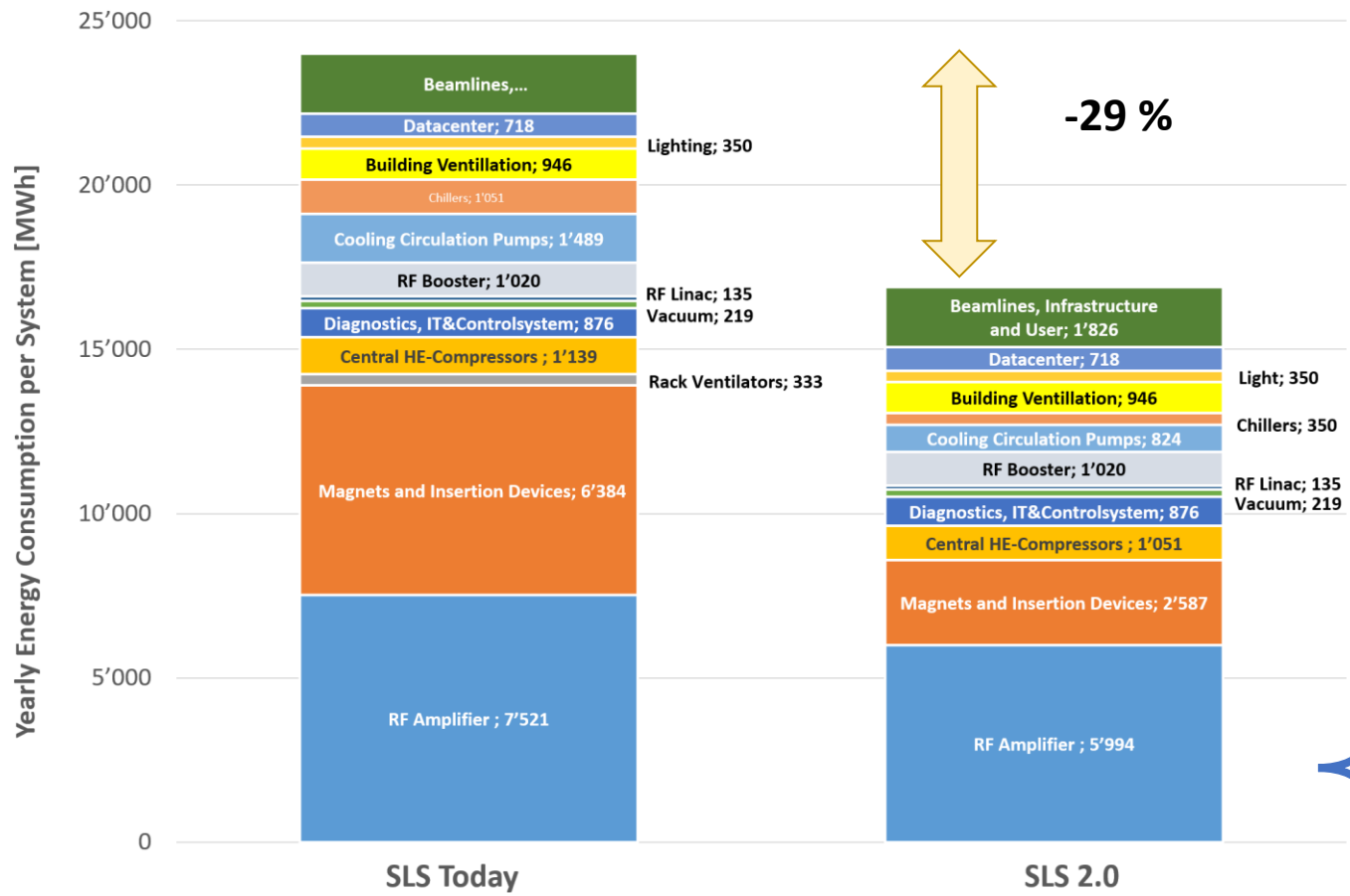

**More radiated X-ray power for users  
Less electricity consumption**

	SLS	→	SLS2.0
$E_{e^-}$	2.4 GeV	→	2.7 GeV
$P_{SR}$	310 kW	→	365 kW
$W_{elec}/y$	24 GWh	→	17 GWh

Key savings:

- Electromagnets → Permanent magnets
- Klystrons → Solid state amplifiers
- standard pumps → modern pumps for cooling

main RF power flow SLS2.0	
AC power	816 kW
DC power	772 kW
RF power to beam	488 kW
power to beam	366 kW
dipole/undulator radiation	275 kW / 91 kW

95%  
63% SSA  
75%

[M.Jörg, PSI]



# Free Electron Laser

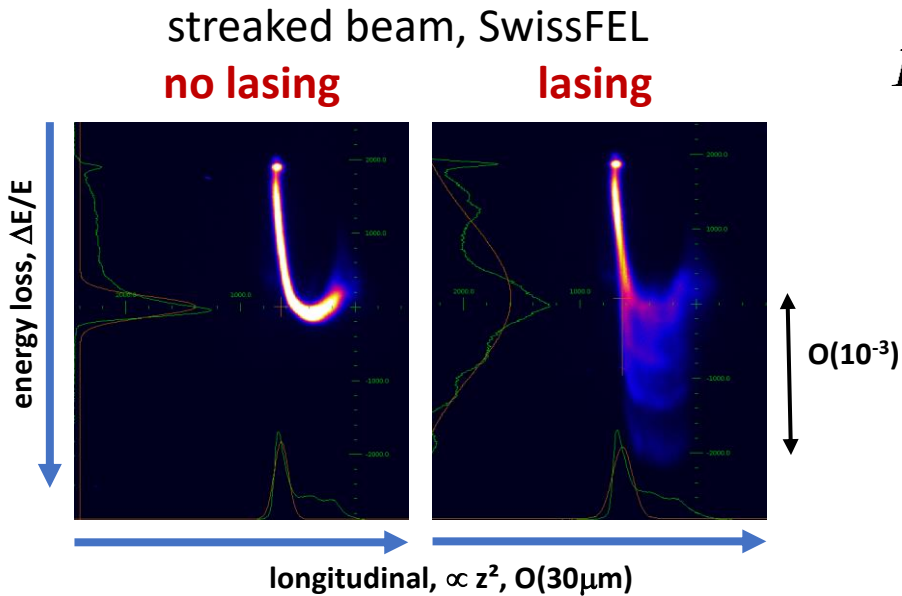

Grid Power Consumption  
 (order of magnitude)  
 examples: n.c. / s.c.

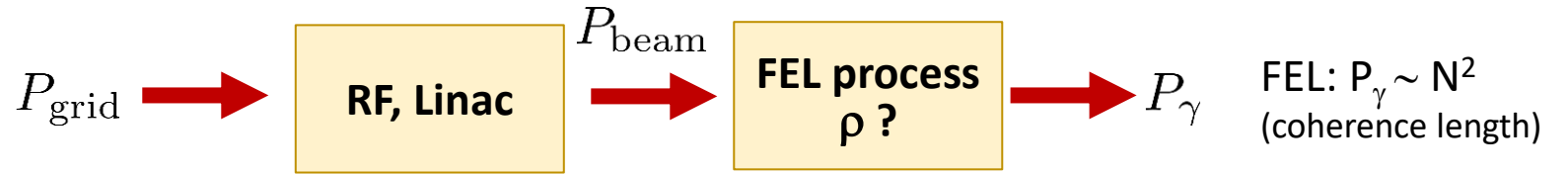

best demonstrated  
 energy extraction:  
 $\Delta E/E = 30\%$

( $E_k=65\text{MeV}$ , Laser seeded FEL)

PRL 117, 174801 (2016)      PHYSICAL REVIEW LETTERS      week ending 21 OCTOBER 2016

**High Efficiency Energy Extraction from a Relativistic Electron Beam in a Strongly Tapered Undulator**

N. Sudar, P. Musumeci, J. Duris, and I. Gadjev  
*Particle Beam Physics Laboratory, Department of Physics and Astronomy, University of California Los Angeles, Los Angeles, California 90095, USA*

M. Polyanskiy, I. Pogorelsky, M. Fedurin, C. Swinson, K. Kusche, and M. Babzien  
*Accelerator Test Facility, Brookhaven National Laboratory, Upton, New York 11973, USA*

A. Gover  
*Faculty of Engineering, Department of Physical Electronics, Tel-Aviv University, Tel-Aviv 69978, Israel*  
 (Received 3 May 2016; published 19 October 2016)

Facility	Technology	$P_{\text{grid}}$ (typ)	$P_{\text{beam}}$ (typ)	Photon Power
SwissFEL	n.c., 6 GHz, pulsed	$\approx 3.0$ MW	100 W	up to 0.2 W
EXFEL	s.c., 1.3 GHz, pulsed	$\approx 10$ MW	40'000 W	up to 40 W



# Particle Colliders

# Colliders - Concepts

Next generation: high Luminosity, high Energy reach needed  
Energy Efficiency: Luminosity per Grid Power

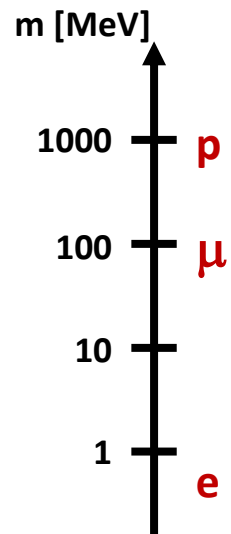
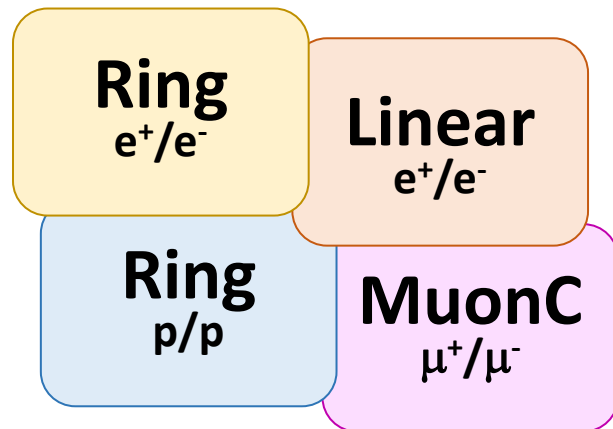

particle mass impacts synchrotron radiation and beamstrahlung (collision)

→ scaling laws and grid power drivers are quite different for the concepts under discussion



# Colliders Types and Power Drivers

**Ring**  
e<sup>+</sup>/e<sup>-</sup>

FCC-ee 240GeV:  
P<sub>grid</sub> = 273MW

+ beam recirculation  
- synchrotron radiation

$$P_{\text{SR}} \propto I_{\text{beam}} \left( \frac{E}{m_0} \right)^4 \frac{1}{R}$$

**Linear**  
e<sup>+</sup>/e<sup>-</sup>

CLIC 380GeV (3.0TeV):  
P<sub>grid</sub> = 252MW (589MW)  
ILC 250GeV (1TeV):  
P<sub>grid</sub> = 111MW (300MW)

+ no synchrotron radiation  
- no recirc., small beam needed  
**power drivers:** cryo (ILC) vs RF (CLIC)

$$L_{\text{lin.col.}} \propto H_D \sqrt{\frac{\delta E}{\varepsilon_{x,n}}} P_{\text{beam}}$$

**MuonC**  
μ<sup>+</sup>/μ<sup>-</sup>

MAP 6.0TeV:  
P<sub>grid</sub> = 270MW

+ no Beamstrahlung-Limitation  
- inefficient RCS, complexity

$$L_{\text{mu.col.}} \propto B \frac{N_0}{\varepsilon_{xy,n}} \gamma P_{\text{beam}}$$

**Ring**  
p/p

FCC-hh 100TeV:  
P<sub>grid</sub> = 580MW

+ high energy reach  
- SR deposited @50K, cryogenics

$$P_{\text{SR}} \approx 5 \text{ MW}$$

$$\rightarrow P_{\text{grid,SR}} \approx 100 \text{ MW (17\%)}$$



# Ring Collider

- energy recirculated, thus efficient concept
- however, SR losses at higher energies
- comment: for LHC burnup dominates beam loss (no SR)

quality factor storage ring:  $Q_\gamma = \omega \frac{E_{\text{stored}}}{P_{\text{dissipated}}} = 2\pi \frac{E}{\tau P_\gamma} = 2\pi \frac{E}{U_0} \gg 1$  = „decay time of beam energy in number of turns due to SR“

bending radius

$$Q_\gamma = \frac{3}{2} \frac{\rho}{r_c} \gamma^{-3}$$

classical particle radius

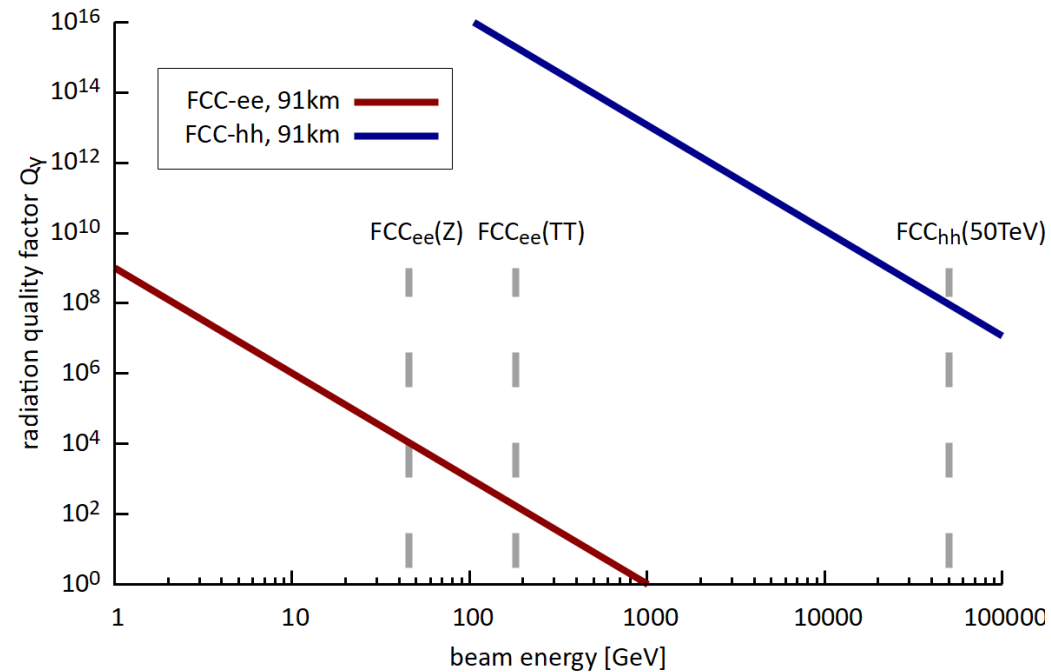

# FCC-ee – Optimized Lepton Ring Collider

## conceptual measures:

- crab waist scheme (specific luminosity)
- 4 IP's instead 2
- maximise bending field fill factor (next talk)

## technology measures:

- high-efficiency klystrons (HEIKA collaboration)
- 4.5 K s.c. cavities, high Q (400 MHz Nb/Cu)
- twin aperture dipoles (50% savings of bends)
- HTS quads and sextupoles, nested combined function magn.

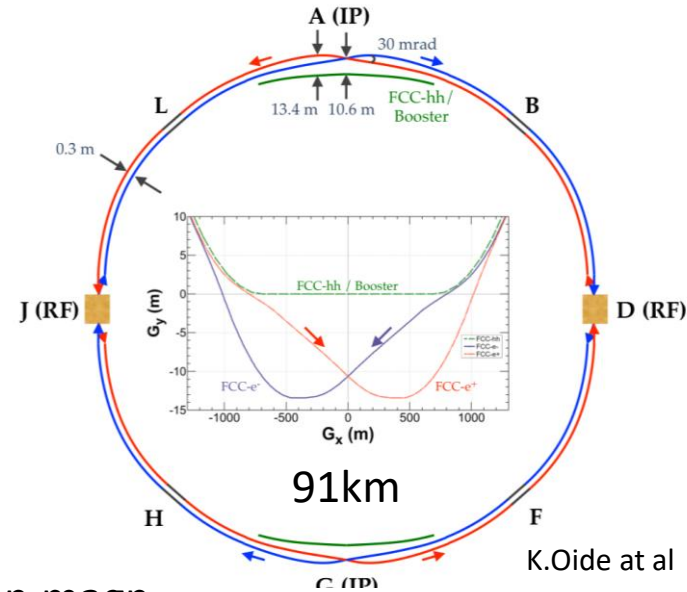

A. Milanese, Efficient twin aperture magnets for the future circular  $e^+/e^-$  collider, Phys. Rev. Accel. Beams 19, 112401 (2016)

similar as  
CERN total  
today

$$E_{cm} = 240 \text{ GeV (H)}$$

$$P_{grid} = 273 \text{ MW}$$

$$E_{grid}/y = 1.33 \text{ TWh}$$

→ dominated by RF  
(compensating SR losses)

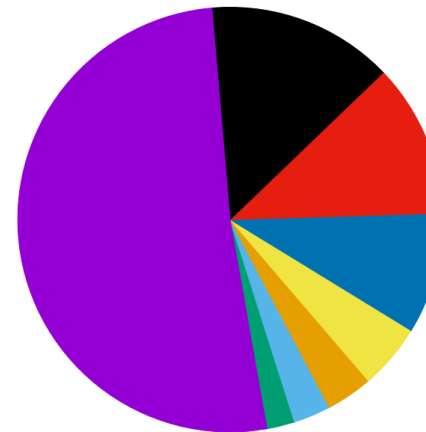

- Radiofrequency
- Services
- Ventilation
- Magnets
- Cryogenics
- Injector
- Experiments
- Booster



# Overview Lepton Proposals

energy specific  
luminosity production:

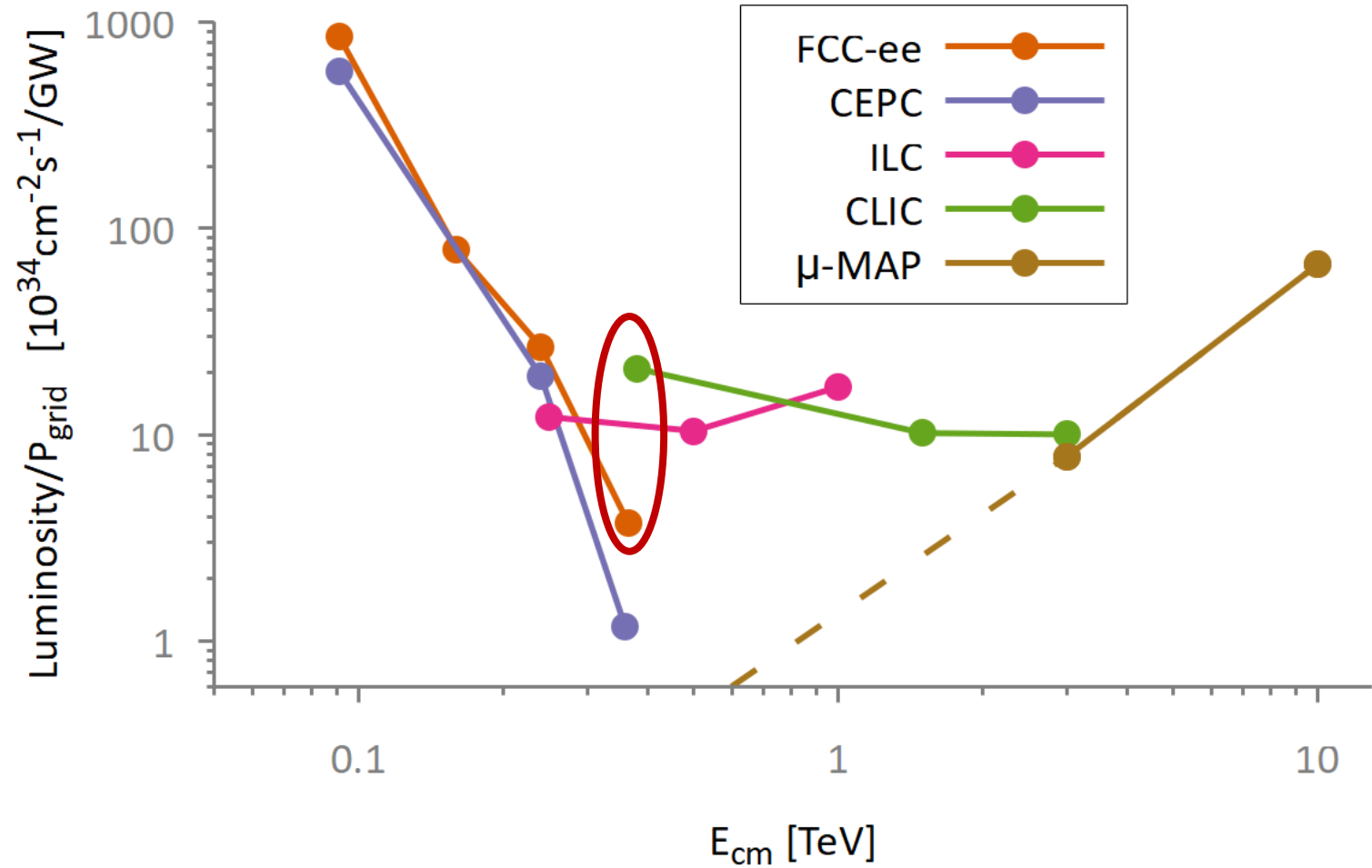

# Ring vs. Linear Collider

**Ring Collider**  
beams circulate

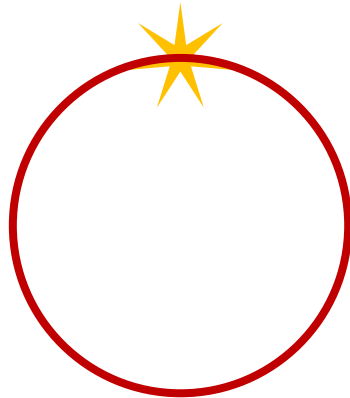

- beam reused
- synchrotron radiation dominated
- equilibrium beamsizes → collision parameters limited

**Linear Collider**  
beams collide once



- beam used only once
- no synchrotron radiation
- ambitious collision parameters possible (no ring dynamics)

	<b>FCC-ee</b> 365GeV	<b>CLIC</b> 380GeV
$\sigma_x$ [nm]	39'000	150
$\sigma_y$ [nm]	69	2
$\sigma_z$ [ $\mu\text{m}$ ]	2'950	70
N [ $10^9$ ]	264	5,2
$f_b$ [kHz]	118	17,6
$P_b$ [MW]	912	2.8



# Combining Linear- and Ring-Collider using the ERL Concept

**ERL**  
power circulates

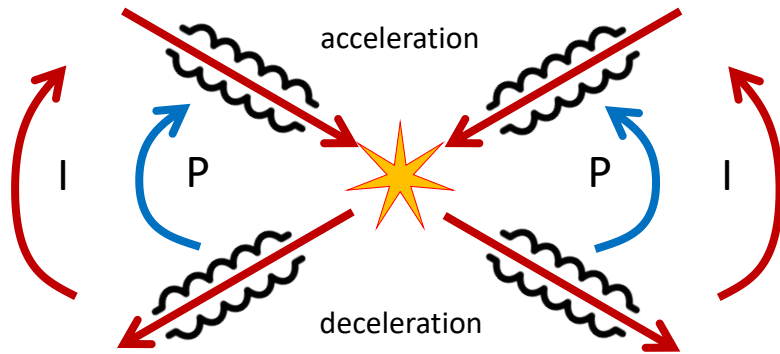

- power recirculated, beam recirc. at low E
- benefit from better collision parameters

→ **high L per grid power, but higher investments & complexity**

two ERL proposals published:

## 1) Circular Energy Recovery Collider

V. Litvinenko, T. Roser, M. Llatas, Physics Letter B 804 (2020) 135394

multi turn ERL, modification FCC-ee

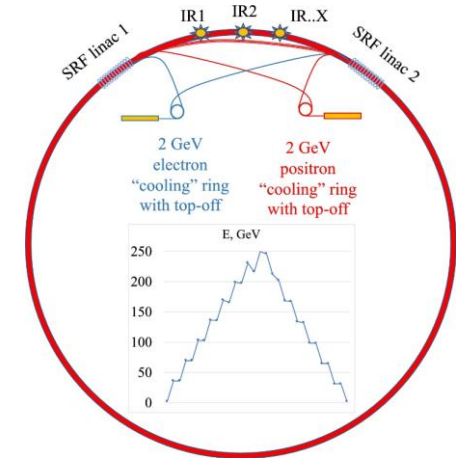

## 2) Energy Recovery Linear Collider

V.I. Telnov 2021 *JINST* 16 P12025

twin s.c. linacs, beam recirculation, wiggler damping

Twin LC with energy recovery

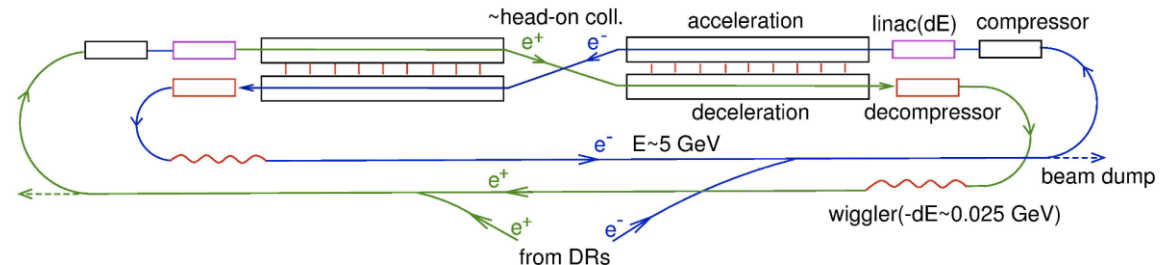

# Muon Collider – Efficient at Highest Energies

Muon:  $E_0 = 106 \text{ MeV}$ ,  $\tau_\mu = 2.2 \mu\text{s}$

mass x 200 compared to electrons:

**low SR, low beamstrahlung during collisions!**

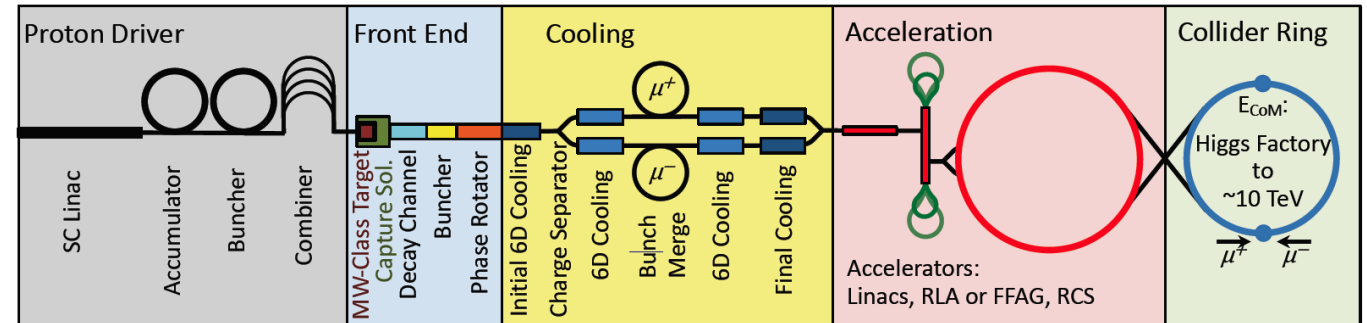

Beamstrahlung in  $e^+/e^-$  collider, mitigation results in limitation of IP beam parameters and flat beams:  $\sigma_x \gg \sigma_y$

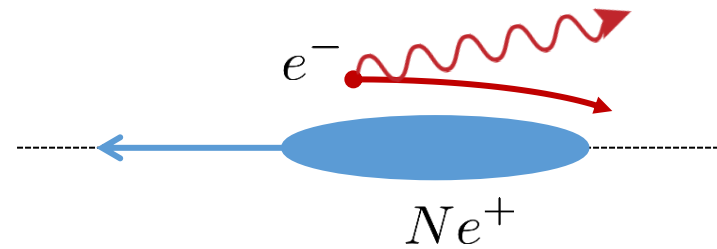

# Energy scaling of the Muon Collider

- 1) particle physicists demand a fixed relative energy spread during collisions, across varying collision energies  $\longrightarrow \frac{\delta E}{E} \approx 10^{-3}$
- 2) with given longitudinal emittance the product of bunch length and energy spread is constant across energies  $\longrightarrow \sigma_z \propto \frac{1}{\delta E} \propto \frac{1}{\gamma}$
- 3) hourglass effect: length of IP waist and bunch length are of same order of magnitude (beta-function at IP)  $\longrightarrow \beta_{x,y}^* \propto \sigma_z$
- 4) the beam can be made smaller with increasing energy  $\longrightarrow \beta_{x,y}^* \propto \frac{1}{\gamma}$

thus L/P is increasing with energy\*:

$$\mathcal{L} \propto \frac{N^2}{\sigma_x \sigma_y} \propto \frac{N^2}{\sqrt{\varepsilon_x \beta_x^* \varepsilon_y \beta_y^*}} \propto \frac{N^2}{\varepsilon_n} \gamma^2 \propto \frac{N}{\varepsilon_n} \gamma P_{\text{beam}}$$

\* the grid power is assumed roughly proportional to beam power



# other aspects of sustainability

- rare earths, critical materials
- carbon footprint of components, construction, operation
- heat recovery
- carbon footprint of tunnel dominates

## Übersicht

Zeitplan

Anmeldung

Information

Participant list

Impressions of the work shop

## Orga

✉ denise.voelker@desy.de

✉ andrea.klumpp@desy.de

Life Cycle Assessments get more and more in the focus in industry and also in science. iFAST presents a platform for discussing and finding solutions in these topics.

In our workshop we want to focus on the Life Cycle Management using the example of Rare Earths Elements (REE), the key material in permanent magnets used in a variety of fields like accelerator, turbines, hard drives and many more.

On the workshop we will discuss the following points:

- Life cycle management  
Consider entire life cycle of technical component using critical materials:  
construction – operation – deconstruction
- Mining and processing of REE  
a socio-ecological approach – energy savings versus destructive mining and processing
- Using permanent magnets  
Examples of the use of permanent magnets and its Pro and Con
- Certification for mining and processing of REE  
How to force more sustainable thinking in the production of REE
- Recycling of permanent magnets  
New processes for the re-use and recycling of permanent magnets
- Alternatives for permanent magnets with REE  
New magnetic materials as well as improved electromagnets

Science, industry, politics and NGO in cooperation can forces to tackle the problem – we can develop solutions together.

## Topics:

- rare earths: benefits and issues
- assessing carbon footprint, env. impact, societal impact ...
- supply chains and certification
- recycling



# Petra Zapp (IEK-STE), excerpt: Comparison of Wind Generator Types

**example of complex assessment: Influence of RE origin (ore type, mining location, specific site conditions) on environmental impacts per 1 kWh electricity generated by 3 MW wind power**

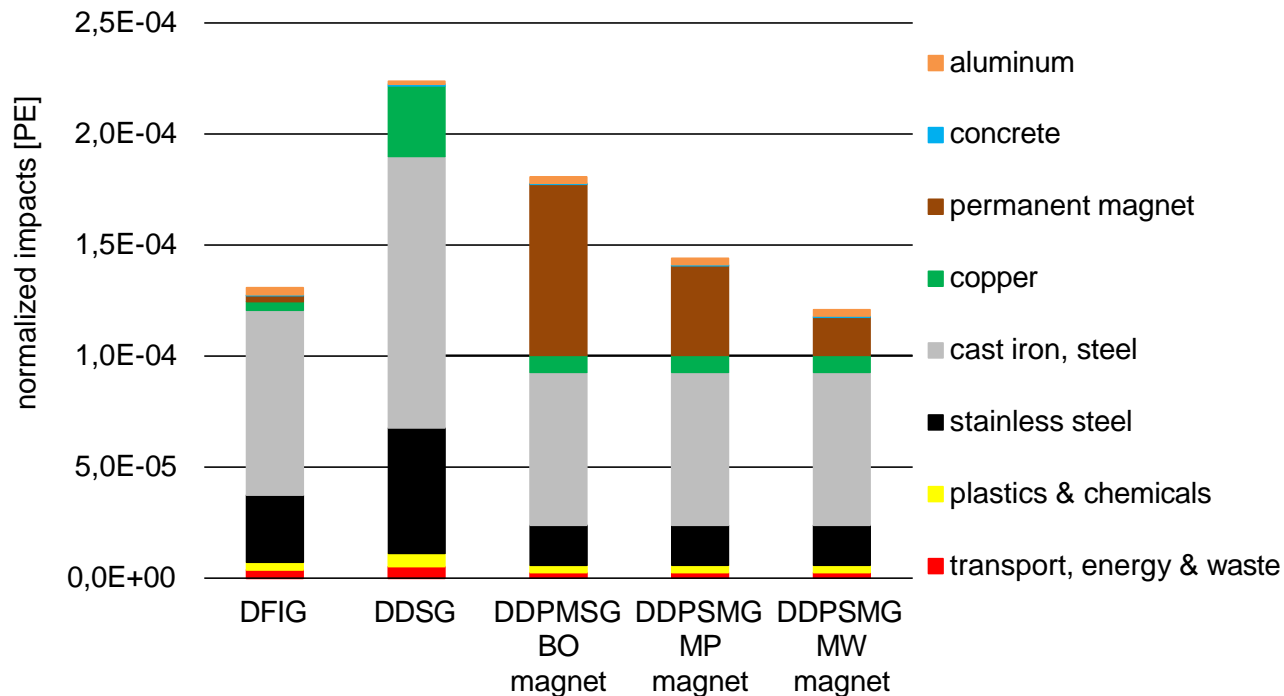

- Electricity generation by DDPMSG with permanent magnet produced from Chinese RE (Bayan Obo) has higher normalized environmental impacts compared to
  - U.S. Mountain Pass (→ 20%)
  - Mt. Weld (Aus) (→ 33%)

DFIG: doubly-fed induction generator

DDSG: direct driven synchronous generator

DDPMSG: electrically excited and direct drive permanent magnet synchronous generator

A. Schreiber, J. Marx and P. Zapp: **Comparative life cycle assessment of electricity generation by different wind turbine types**; Journal of Cleaner Production **2019** Vol. 233 Pages 561-572



# Critical Materials: Niobium for Superconducting Cavities, B.List, DESY

- RRR (Residual Resistivity Ratio) is an indicator of purity
- is defined as the ratio of its electrical resistivity at room temp 273 K to its resistivity at cryogenic temperature
- $RRR \geq 300$  achieved by 6x vacuum remelting
- **estimate by B.List (DESY):**
  - Niobium  $RRR > 300$ , from China: 98kg CO<sub>2</sub>-e / kg;  
(stainless steel ca 5..7 kg CO<sub>2</sub> / kg)
  - > 10% of total GHG for ILC250 accelerator!
  - > large impact reduction potential

cavities based on thin film superconductor can reduce CO<sub>2</sub> footprint (and operate at higher temperature), but technology is not ready for large scale deployment today

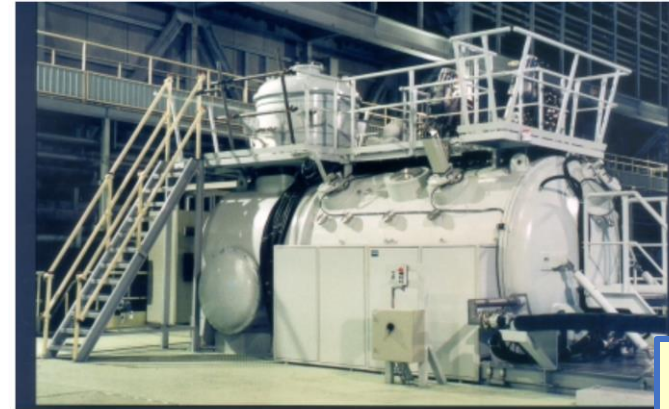

electron beam melting machine

Abbildung 3: Elektronenstrahl Schmelzanlage der Firma von Ardenne Anlagen Technik, Dresden. Typ: EMO 1500 mit 2 \* 750 kW Elektronenstrahlen = 1500 kW Schmelzleistung.

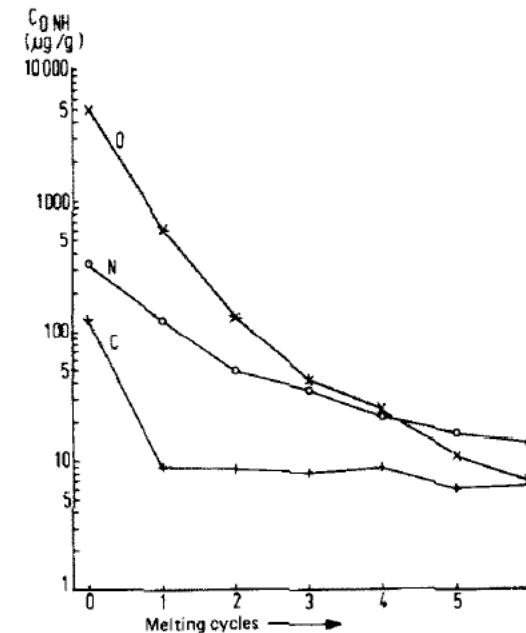

M. Hörmann, J. Less-Common Met. 139(1988)1  
DOI:10.1016/0022-5088(88)90324-4

impurities after n melting cycles

Fig. 5. Gas contents, C<sub>O</sub>, C<sub>N</sub>, C<sub>H</sub>, as a function of the number of melting cycles.



# B.Shepherd (STFC): Electromagnet Operation vs. Manufacturing Footprint

- Power usage at nominal operating point
  - CLARA 1: **385 W**
  - CLARA 2: **2.01 kW**
  - FEBE: **3.72 kW**
- UK electricity carbon intensity 2022: **193 gCO<sub>2</sub>e / kWh** (and improving every year!)
  - Highly dependent on fuel mix:  
Sweden 21g; France 102g; USA 432g; Germany 481g; Switzerland 153g  
(source: [Electricity Maps](#))
- Assume operated for 5 years, 250 days per year, 16 hours per day
- Total impact of operation (*note: cooling not included*)
  - CLARA 1: **1.49 tCO<sub>2</sub>e**
  - CLARA 2: **7.76 tCO<sub>2</sub>e**
  - FEBE: **14.4 tCO<sub>2</sub>e**
- Much greater than manufacture impact

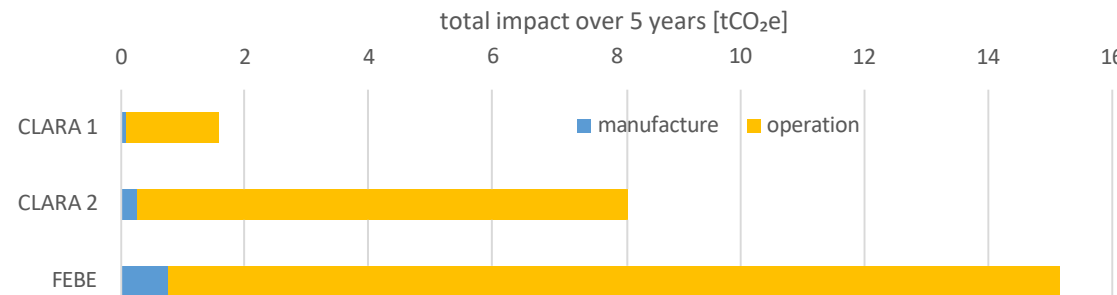
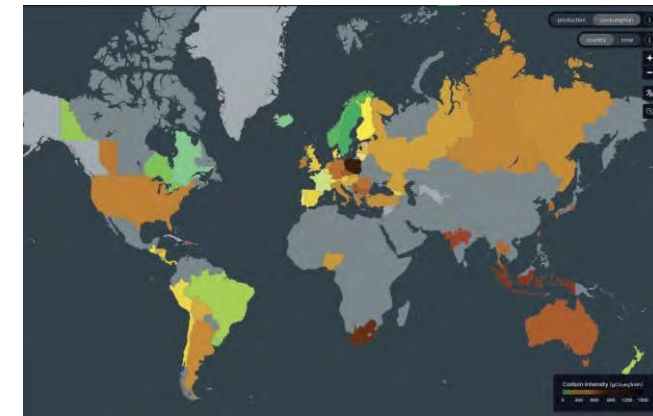
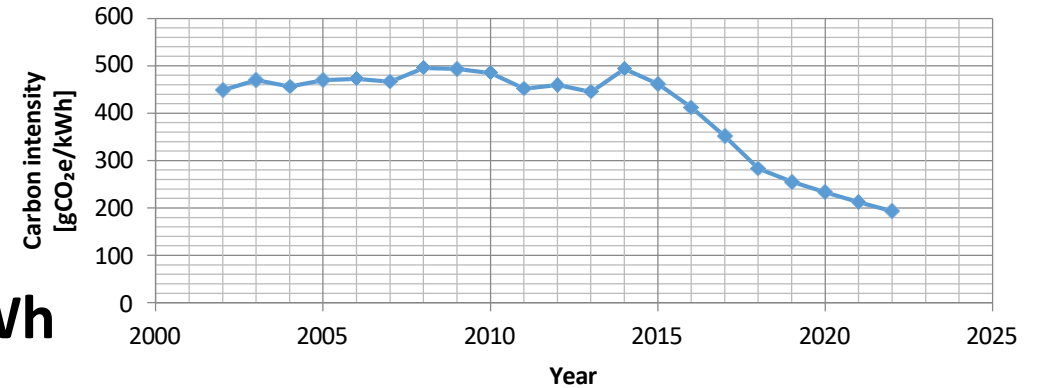

# Supporting measures to increase sustainability of accelerators

## photovoltaic energy production

Option: direct injection of DC power for accelerator systems

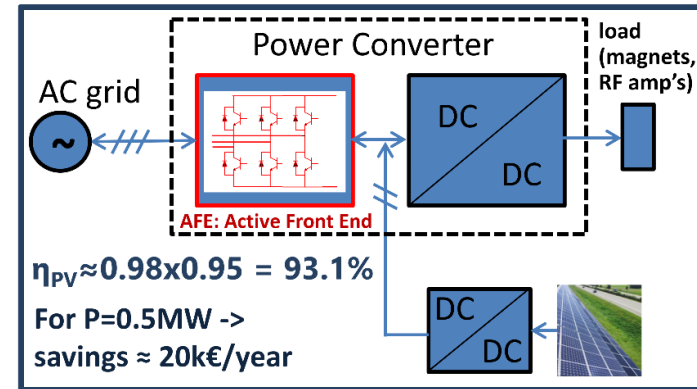

concept idea  
DC injection of PV power  
[C.Martins, ESS, I.FAST]

use of **waste heat for heating**, often limited by low temperature of cooling water  
→ Use heat pumps to provide higher T at the expense of some additional grid power



heat pumps at MAX-4  
[Björn Eldvall / E.ON,  
Martin Gierow / Krafringen]



# B.List et al: CLIC CO<sub>2</sub> Footprint, Tunnel Cross Sections

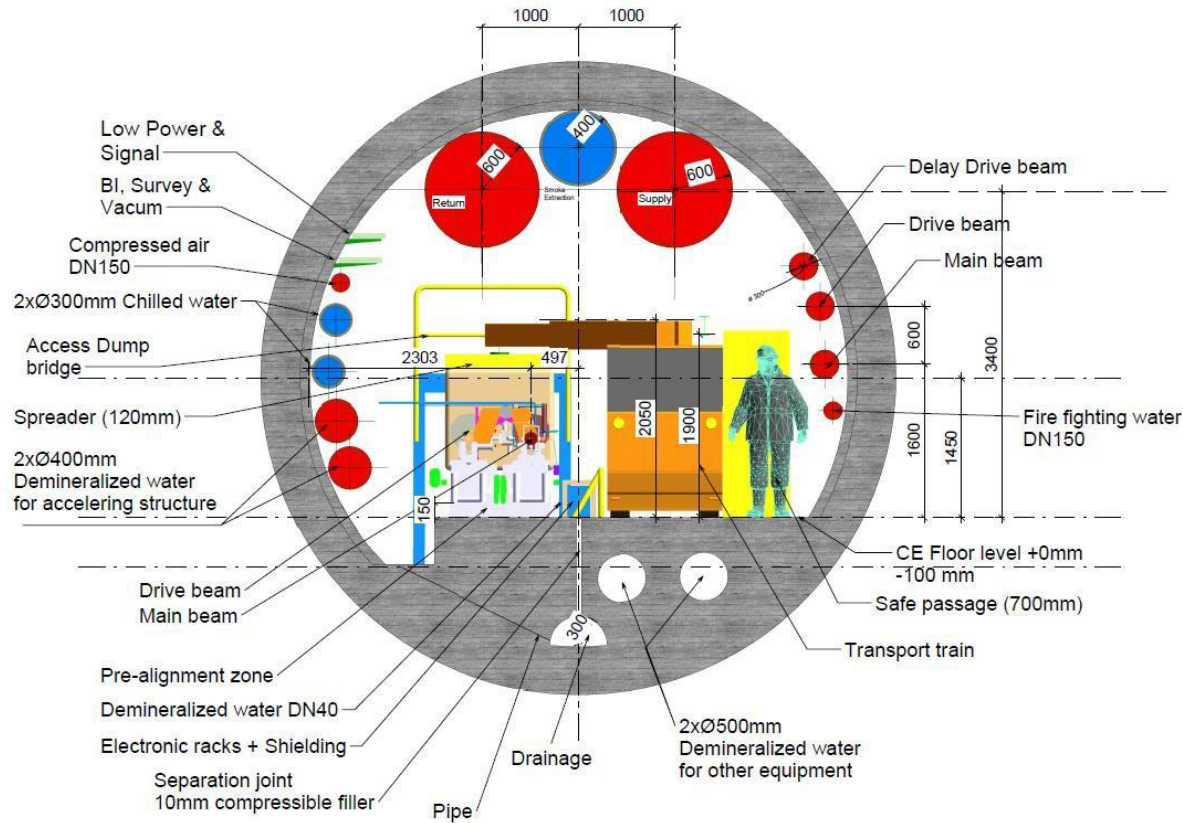

CLIC tunnel (drive beam option), 5.6m diameter

My estimate: 12.4m<sup>2</sup> concrete  
 -> 31 t/m concrete

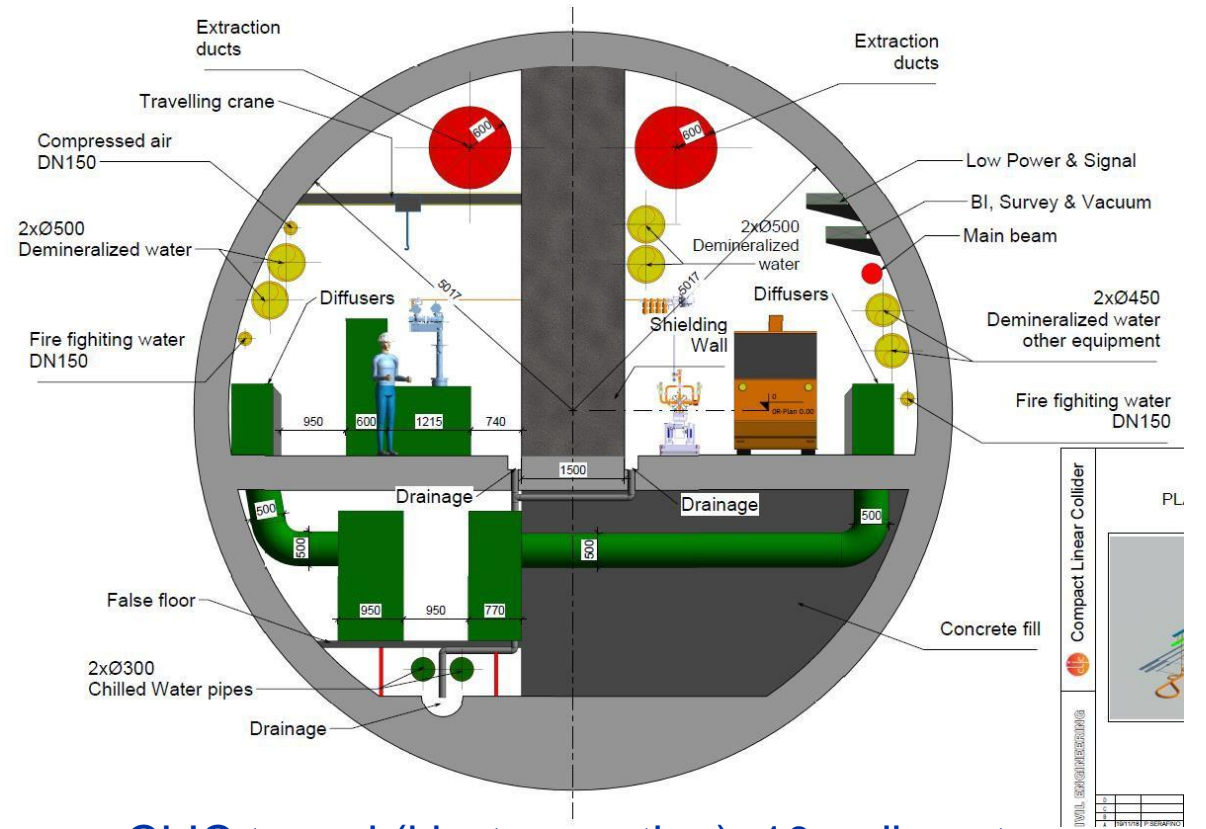

CLIC tunnel (klystron option), 10m diameter

My estimate: 44.8m<sup>2</sup> concrete  
 -> 112 t/m concrete



# The Future – Fluctuating Energy Sources

simulation: April 2050, sustainable energy system, Germany

- production of power
- solar, wind
  - release from storage
  - variation: x5!

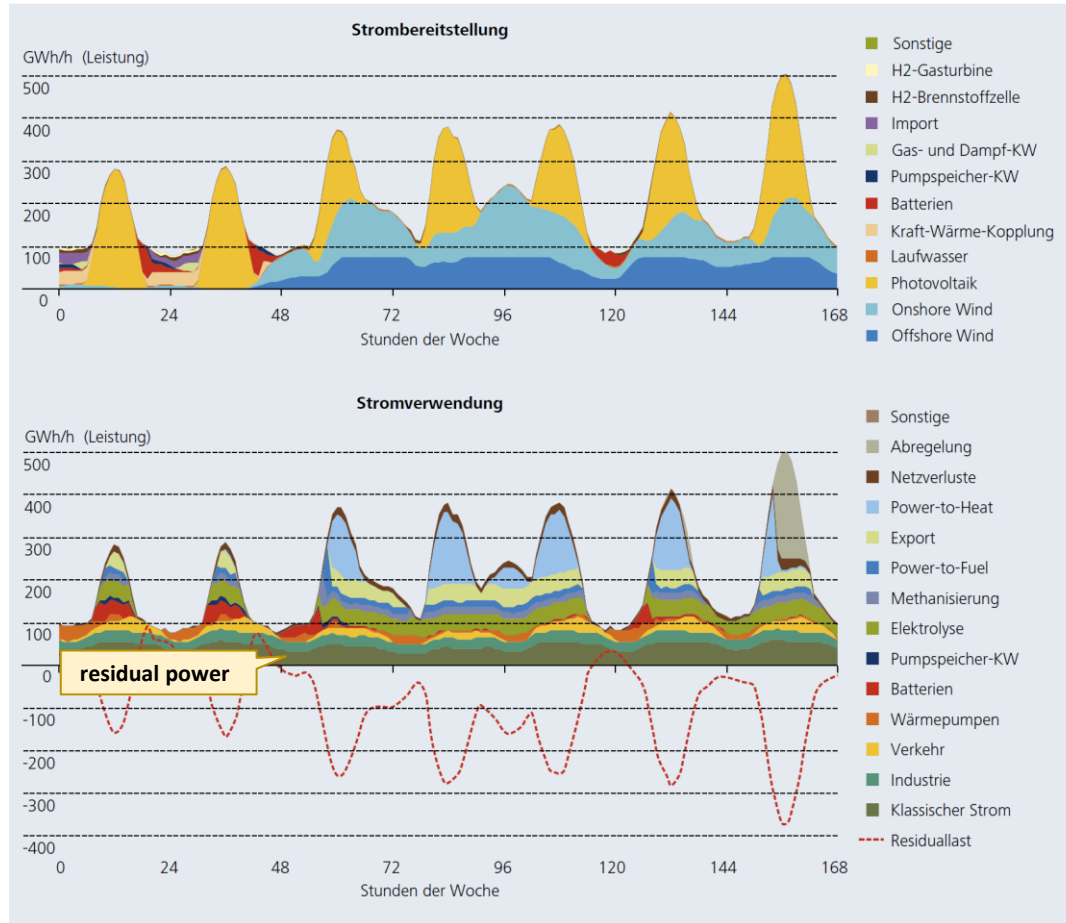

- use of power
- industry, traffic etc
  - energy storage

- full collider operation at times of high grid production
- reduced operation or standby modes with fast L recovery otherwise

courtesy: FRAUNHOFER-INSTITUT FÜR SOLARE ENERGIESYSTEME ISE, Karlsruhe (2020)



# Summary Particle Accelerators

## Grid to Beam

- State of the art 20%, up to 50% reachable for s.c. linacs & high beam power; cyclotrons provide solutions for  $E < 1\text{GeV}$ , e.g. ADS systems

## Colliders

- $e^+/e^-$  ring collider is a powerful yet simple scheme; advanced efficient schemes include energy recovery collider and muon collider
- fluctuating sustainable energy: E management / dynamic operation  
→ use surplus energy for RIs

## Technology

- s.c. magnets & high Q cavities are efficient, **higher temperature operation (HTS)**
- **efficient RF sources, permanent magnets**, heat recovery & photovoltaics
- other: water & He consumption, critical materials, managed lifecycle, carbon footprint, energy procurement, advanced energy production

