

# MC2: Evolution and Future of Synchrotron Radiation Sources

RIKEN SPRING-8 Center

Hitoshi TANAKA

2026/05/16@Deauville

1. History of synchrotron radiation source development
2. Diffraction-limited SR sources
3. Single-pass free-electron lasers
4. Future development direction with a few topics

# Brilliance enhancement over the past century

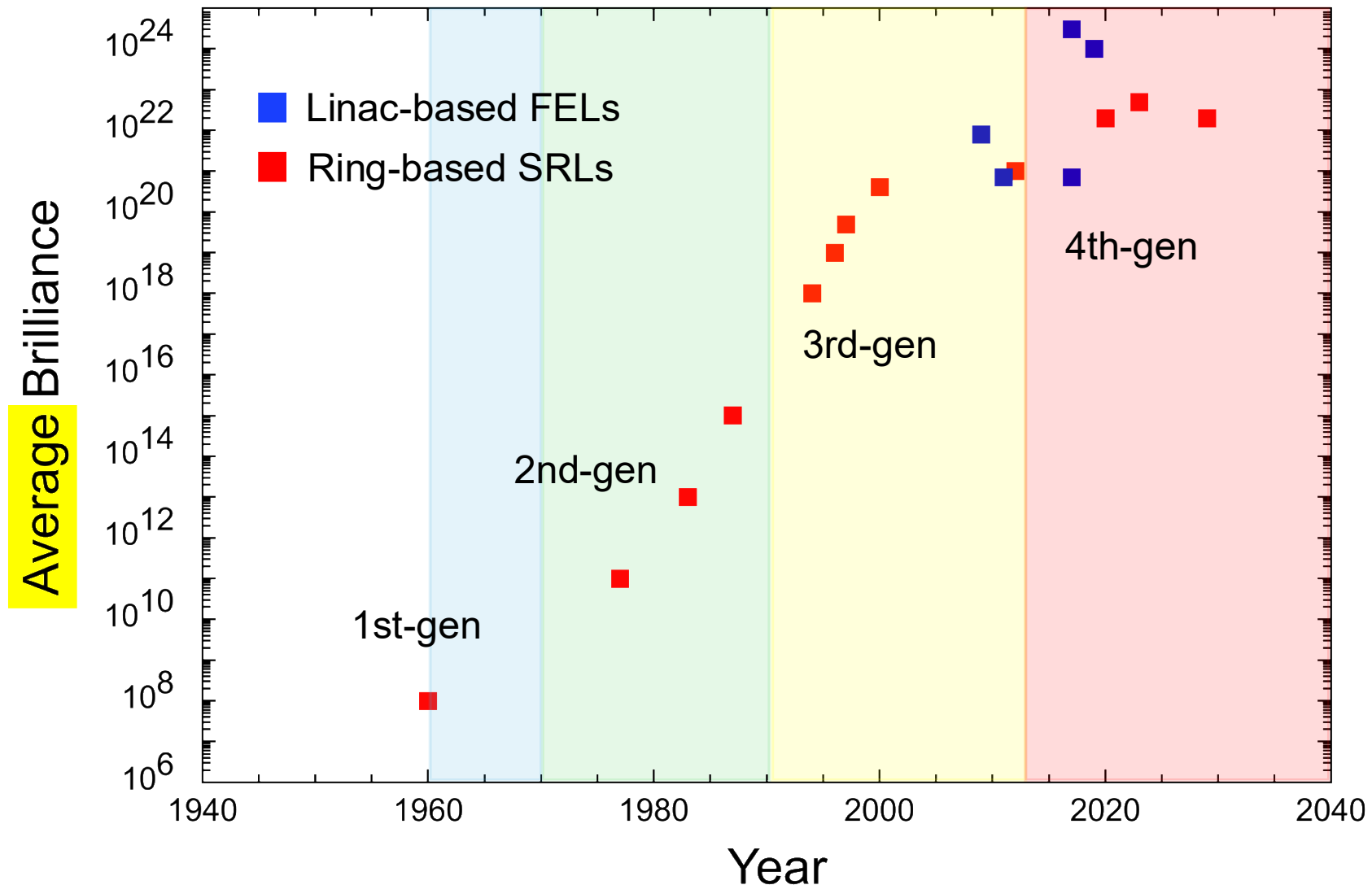

# Brilliance enhancement over the past century

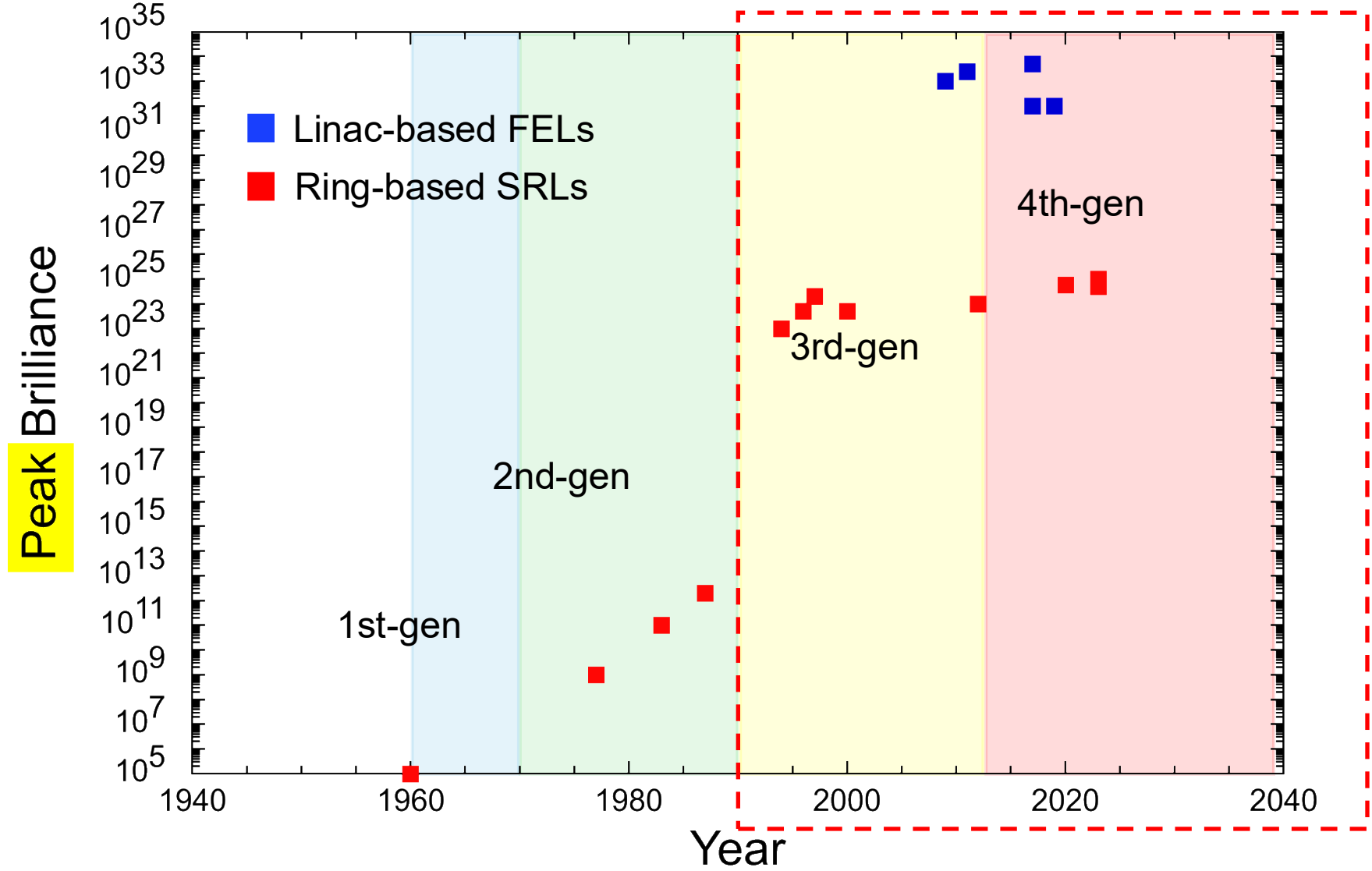

# Recent evolution of SR sources

Performance index: Brilliance

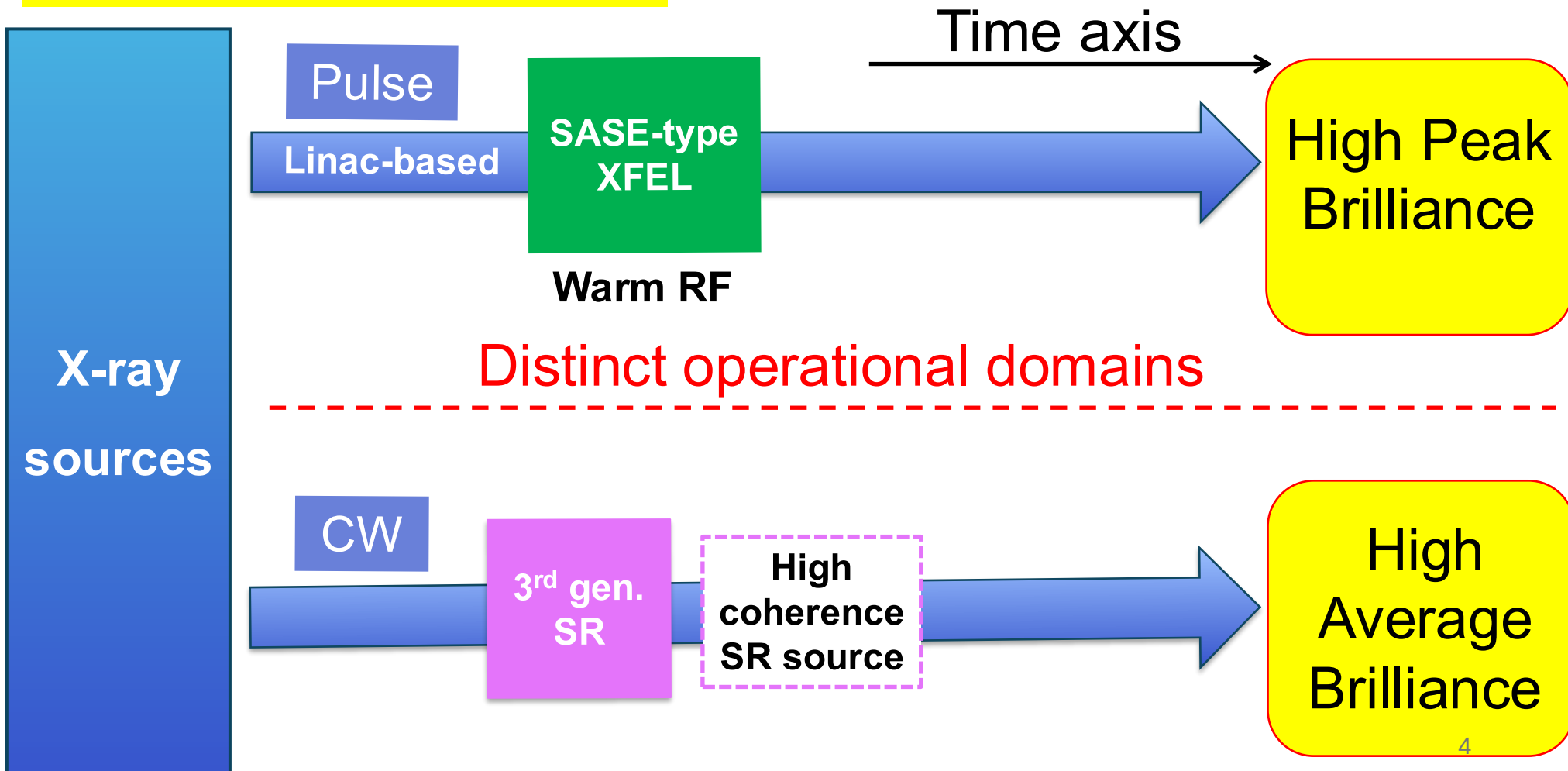

# Recent evolution of SR sources

Performance index: Brilliance

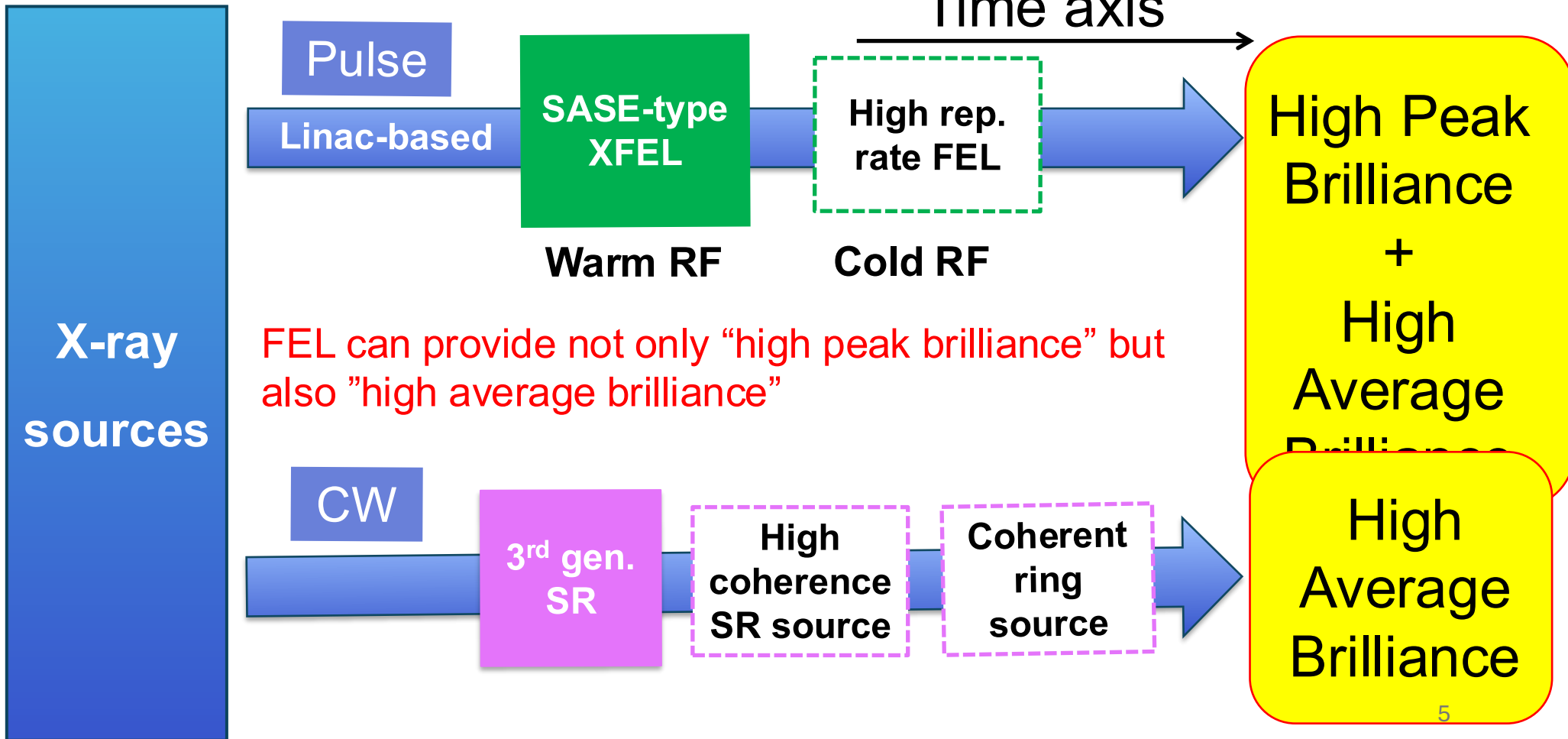

# Recent evolution of SR sources

Performance index: Brilliance

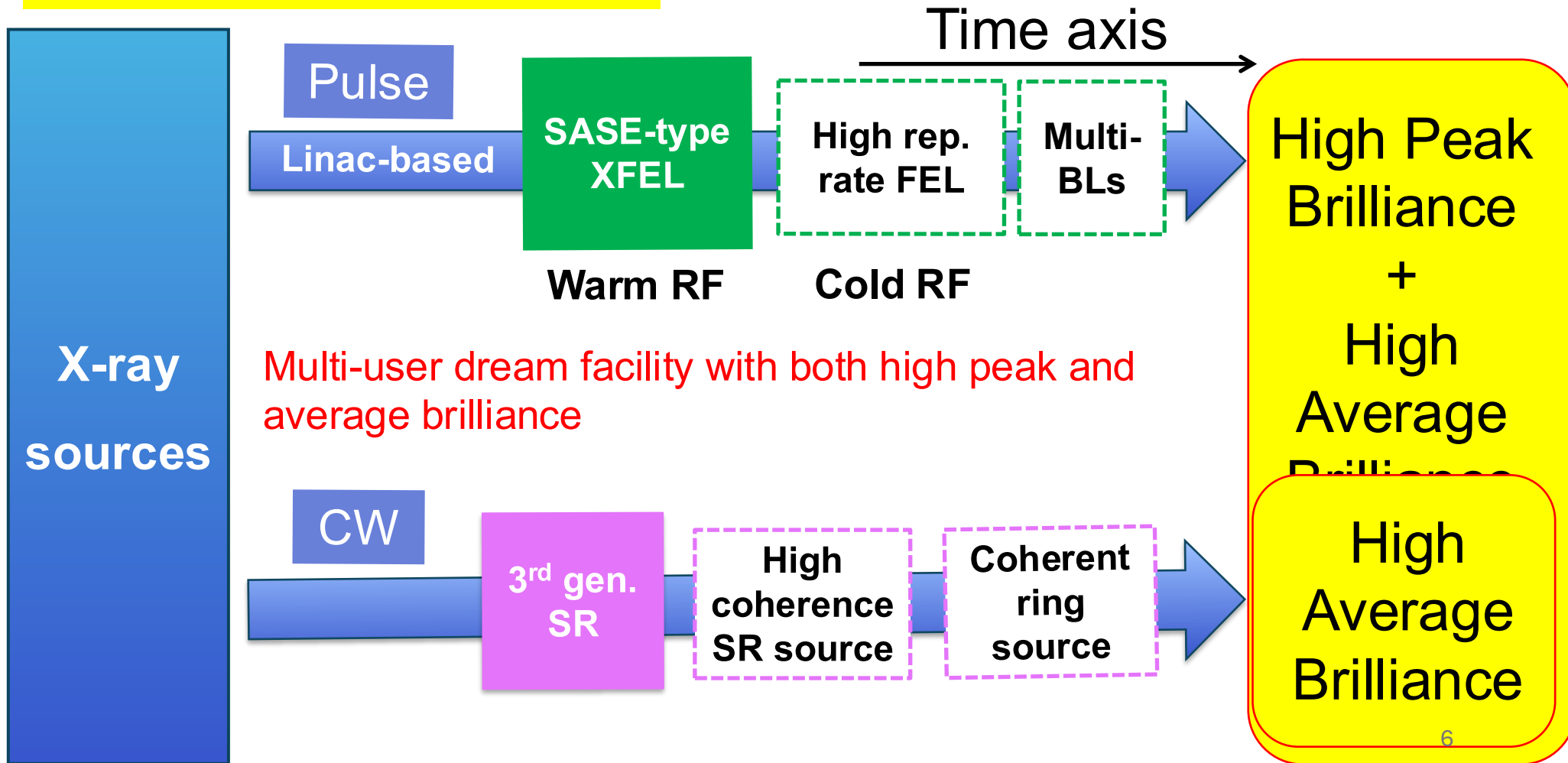

# Role sharing between FELS and ring-based SRs

Performance index: Brilliance

## Image of multi-user dream facility

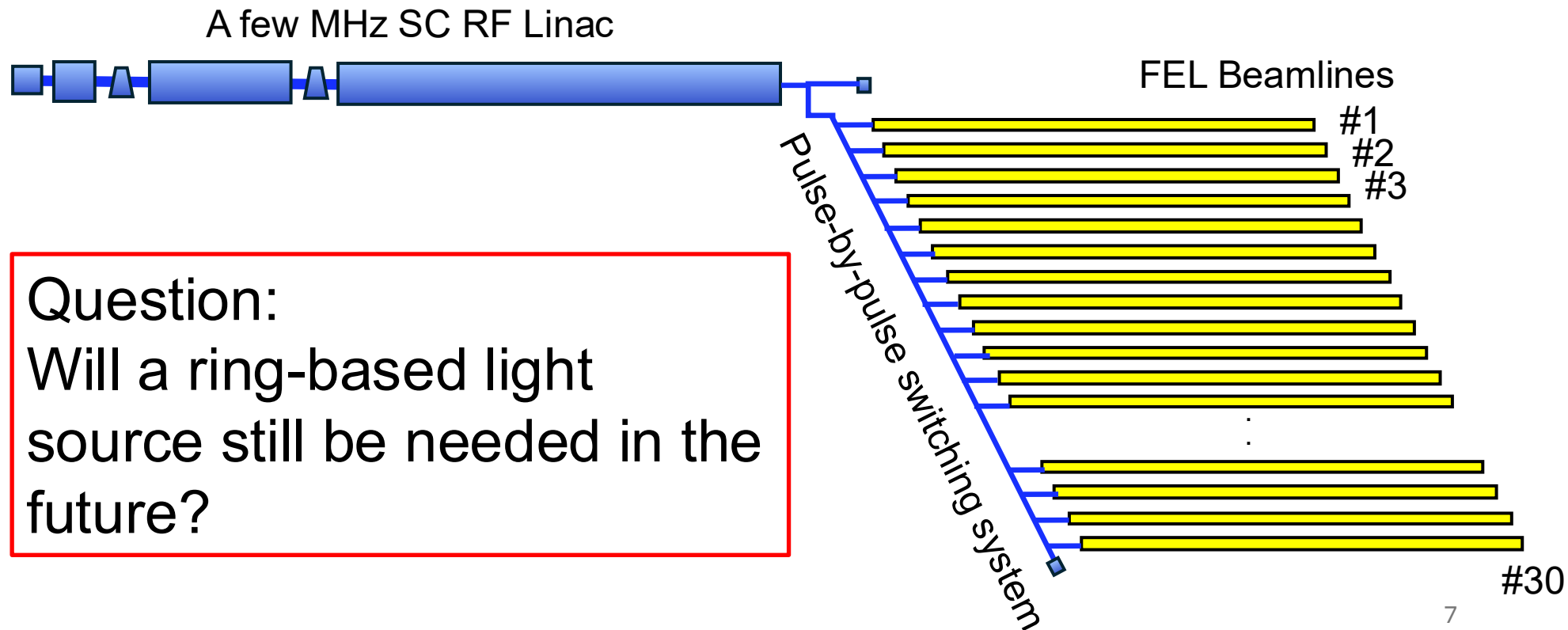

# Role sharing between FELS and ring-based SRs

## Performance characteristics of FELs

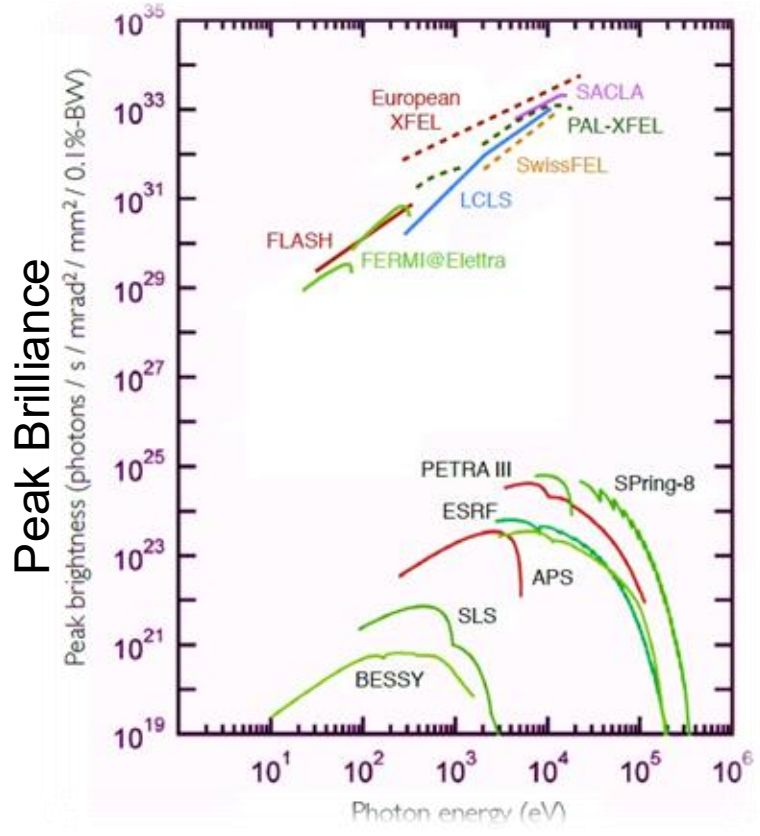

- Limited photon energy from **SX to X**
- High peak brilliance **10<sup>29</sup> to 10<sup>34</sup>**
- High coherence
- Short pulse width **sub to a few tens fs**
- Non-negligible shot by shot variations

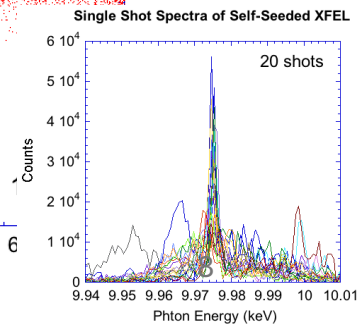
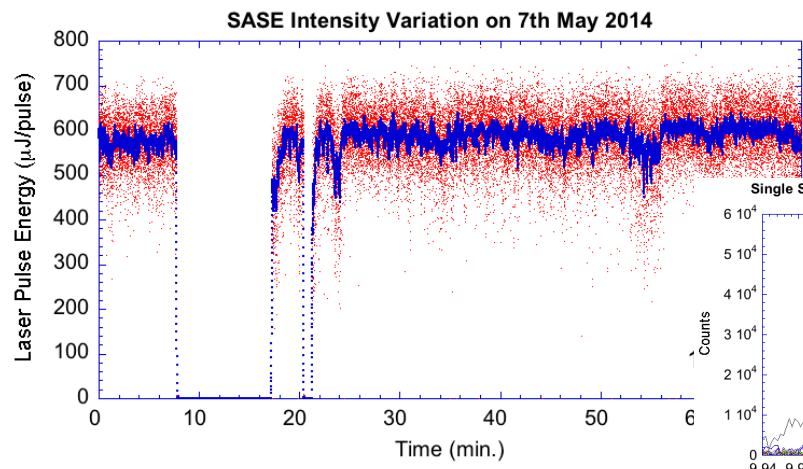

# Role sharing between FELS and ring-based SRs

## Performance characteristics of ring-based light source

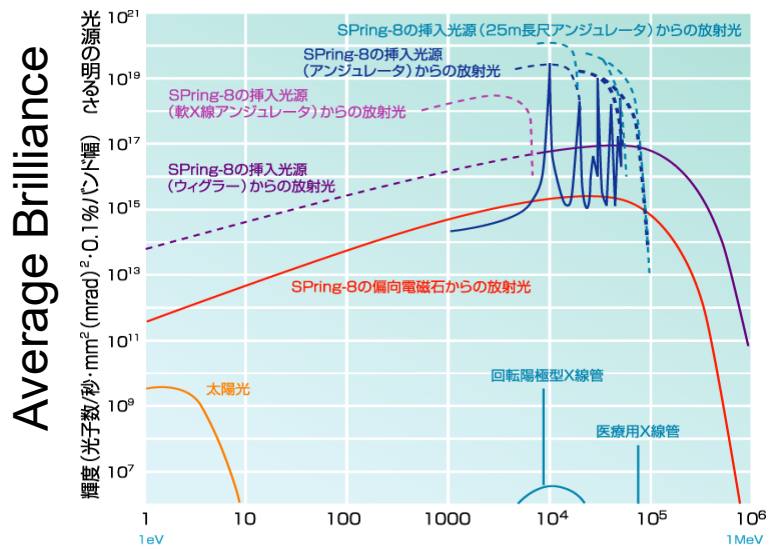

- Photon energy extended to **a few 100 keV**
- Average brilliance from **10<sup>18</sup> to 10<sup>21</sup>**
- Low Coherence
- Long pulse width **a few tens ps**
- High stability and reproducibility

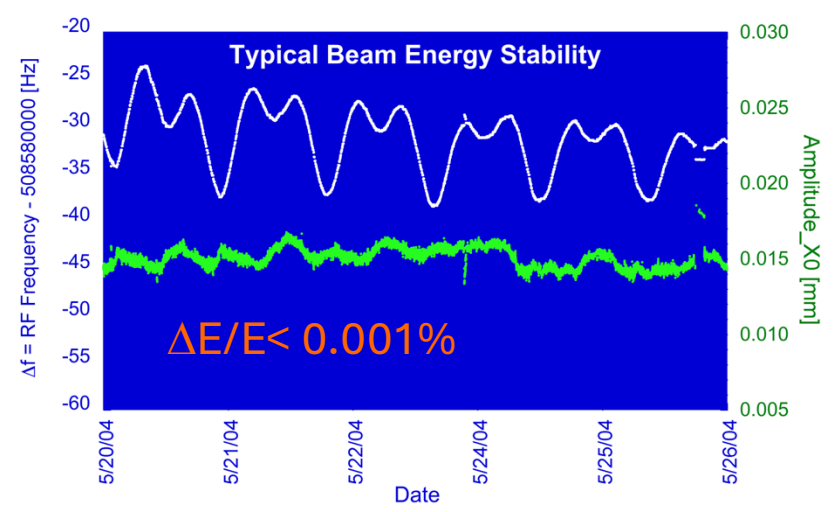
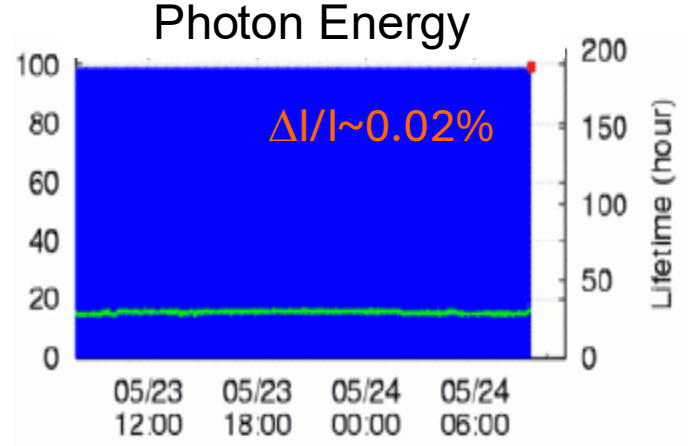

# Role sharing between FELs and ring-based SRs

Systems to be studied by SRs are complex and multi-scaled in time and space

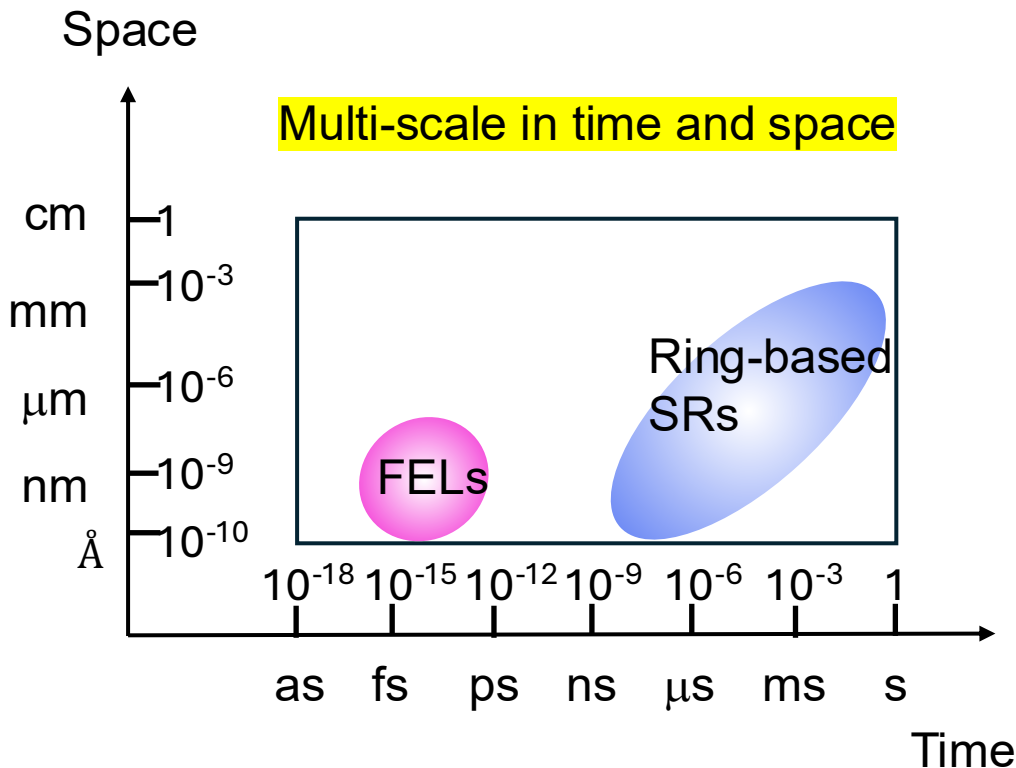

- High peak brilliance is not a universal solution
- High transverse and longitudinal coherence such as a laser is not essential for all experiments
- Correlation measurements using the same sample are extremely useful in various experiments
- The utilization of higher photon energy becomes increasingly important for various applications

1. History of synchrotron radiation source development
- 2. Diffraction-limited SR sources**
3. Single-pass free-electron lasers
4. Future development direction with a few topics

# Diffraction limit

For a given wavelength  $\lambda$ , the product of its size and angular divergence can not be less than  $\lambda/4\pi$  ( $= \varepsilon_{ph}$ ). Assuming undulator radiation with a wavelength of  $\lambda_1$ , and the following product is nearly  $\lambda/4\pi$  in horizontal and vertical direction, this radiation is diffraction limited and of transverse full coherence.

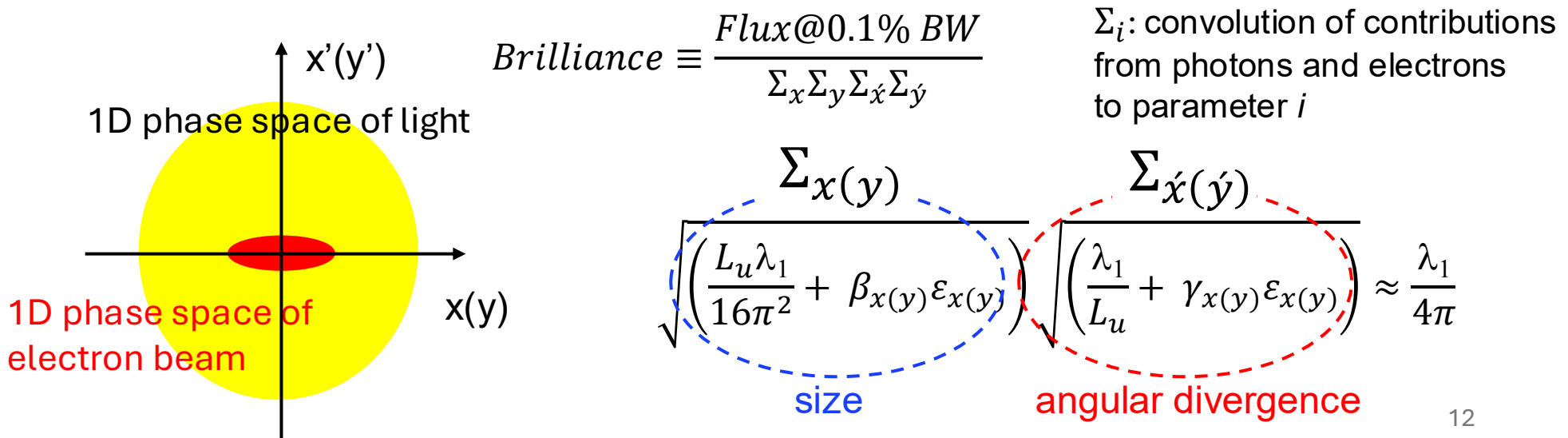

# Scaling of natural emittance

$$\varepsilon = C_q \frac{\gamma^2 \left\langle \frac{H(s)}{\rho(s)^3} \right\rangle}{J_x \left\langle \frac{1}{\rho(s)^2} \right\rangle} \propto \frac{\gamma^2 \theta^3}{J_x},$$

$\gamma$ : Lorentz factor

$\theta$ : Bending angle

$\rho$ : bending radius

H: *H*-function

$J_x$ : Damping partition number

$$H(s) = \frac{1 + \alpha_x^2(s)}{\beta_x(s)} \eta_x^2(s) + 2\alpha_x(s)\eta_x(s)\eta'_x(s) + \beta_x(s)\eta_x'^2(s),$$

$\eta_x$ : Horizontal dispersion

$\eta'_x$ : Horizontal dispersion angle

$\beta_x$ : Horizontal beta

$\alpha_x$ : Horizontal alfa

As the number of bending magnets increases, natural emittance decreases inversely proportional the cubic of that number.

# Suppression of radiation excitation to achieve lower emittance

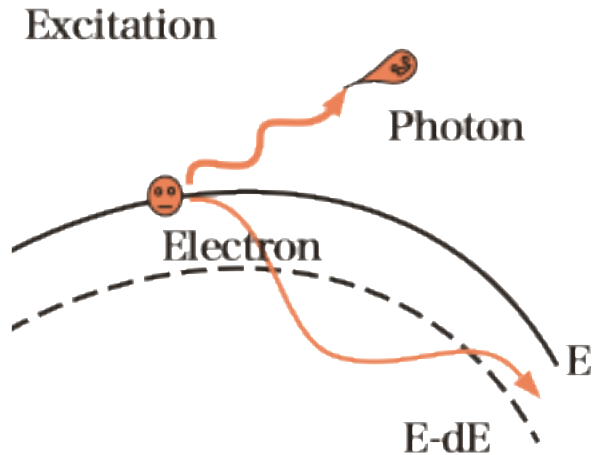

The excited amplitude of a betatron oscillation is determined by the **local energy dispersion**.

The MBA lattice can effectively suppress the energy dispersion along the ring as shown below.

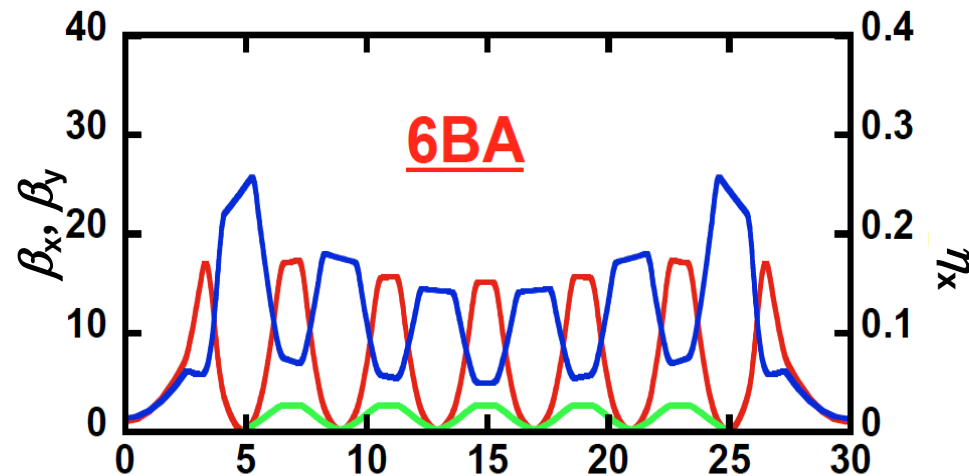
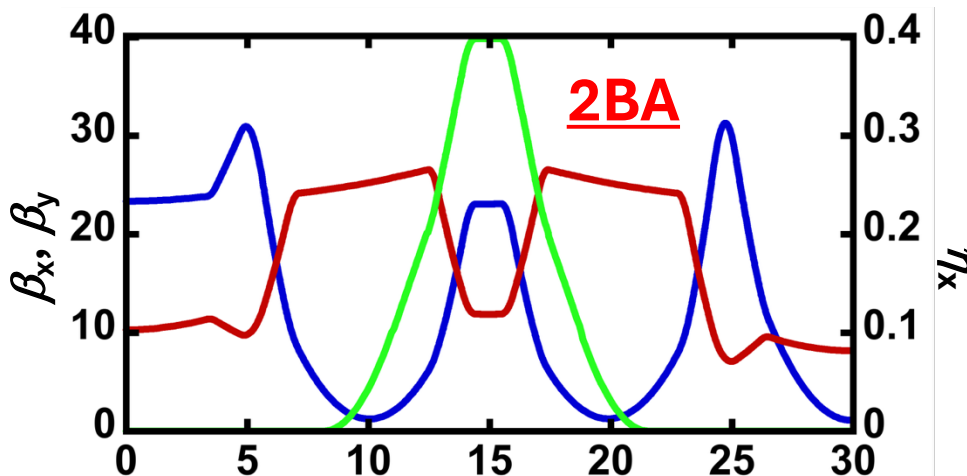

# What breakthroughs made the MBA possible?

The following issues need to be overcome:

1. Narrow space issues
2. Strong nonlinearity from chromaticity correction sextupoles
3. Beam injection scheme applicable for a ring with a small dynamic aperture
4. Stable top-up beam injection compensating a short beam-lifetime and transparent against small emittance stored beam

# What breakthroughs made the MBA possible?

## 1. Solving narrow spacing issues

Q1: The MBA lattice naturally requires the large number of focusing quadrupoles to focus the beam at each BM horizontally.  
**How can numerous magnets be accommodated within a limited space?**

Q2: The shorter focal length and smaller energy dispersion increase the strength of both quadrupole and sextupole magnets.  
**How can extremely strong quadrupole and sextupole fields be achieved?**

# What breakthroughs made the MBA possible?

A1/A2: Adoption of the compact vacuum chamber w/wo NEG coating

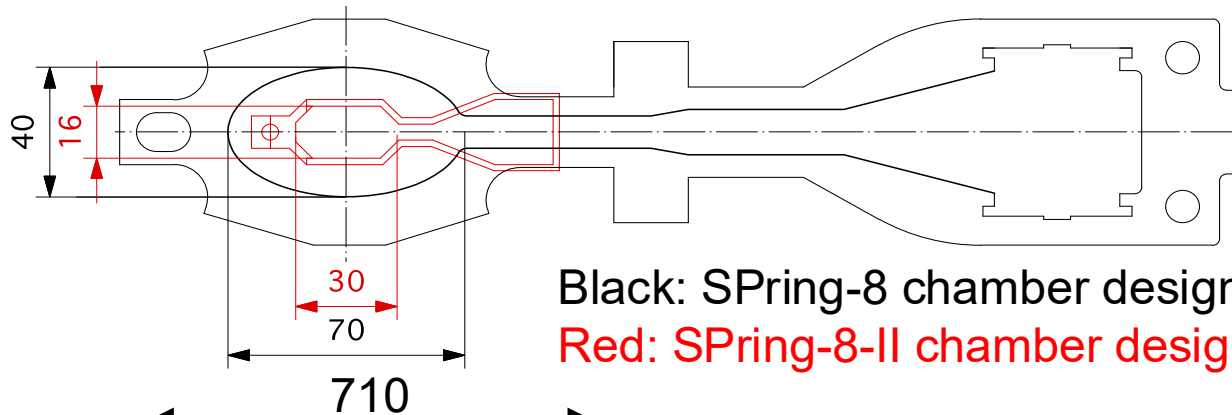

Black: SPring-8 chamber designed 35 years ago  
 Red: SPring-8-II chamber designed recently

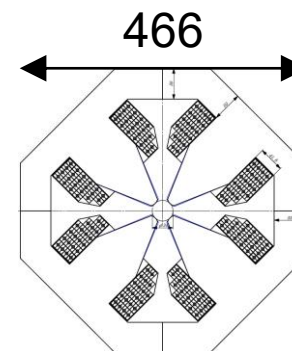
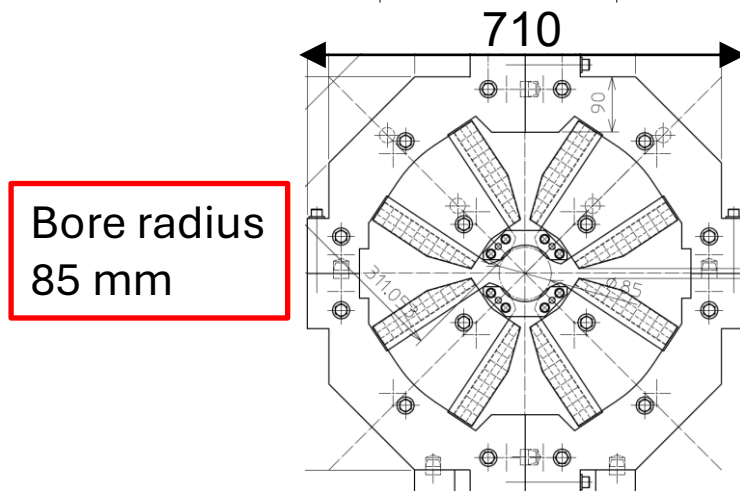

# What breakthroughs made the MBA possible?

A1/A2: Adoption of a single-yoke composite magnet with a spaghetti-type chamber

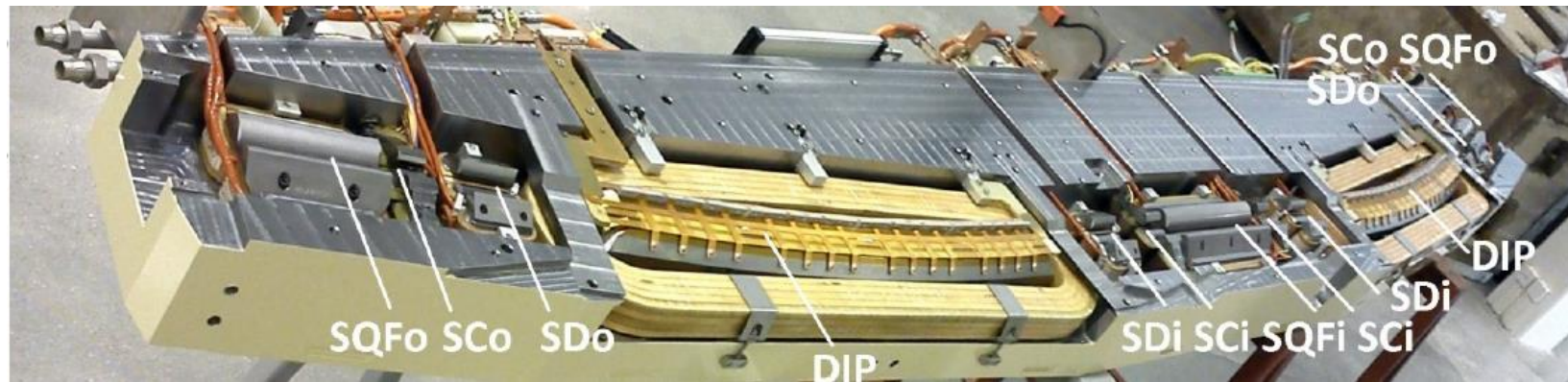

M. Johansson et. al., *Proc. of NAPAC2016*, Chicago, IL, USA (2016) pp. 1058-1066

1. History of synchrotron radiation source development
2. Diffraction-limited SR sources
- 3. Single-pass free-electron lasers**
4. Future development direction with a few topics

# Brief history

The development of a single-pass FEL originated from the TTF (TESRA Test Facility), the test-bed for ILC at DESY and 1.3 GHz superconducting RF system was developed. In **2000**, First SASE (Self-Amplified Spontaneous Emission) lasing was observed at 109 nm [1]. TTF demonstrated the SESE scheme operating in the short-wavelength region, thereby establishing the foundation for X-ray FELs subsequently constructed worldwide.

In **2009**, LCLS (Linac Coherent Light Source) at SLAC achieved first SASE lasing at 0.12 nm using normal conducting S-band linac ( a part of Stanford two-mile linac), out-of-vacuum undulator, RF gun system and so on.

Era of single-pass FEL in short wavelengths was open-up.

[1] J. Andruszkow et. al., *PRL* **85**(18) (2000) 3825-3829

[2] P. Emma et. al., *Nat. Photon.* **4** (2010) 641-547

# Self-Amplified Spontaneous Emission

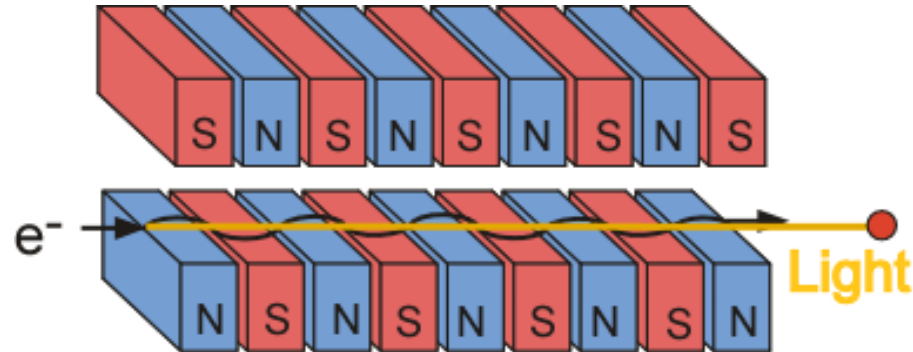

Resonant wavelength of undulator

$$\lambda = \frac{\lambda_u}{2\gamma^2} \left( 1 + \frac{K^2}{2} \right)$$

$$K = \frac{eB_u\lambda_u}{2\pi m_e c}$$

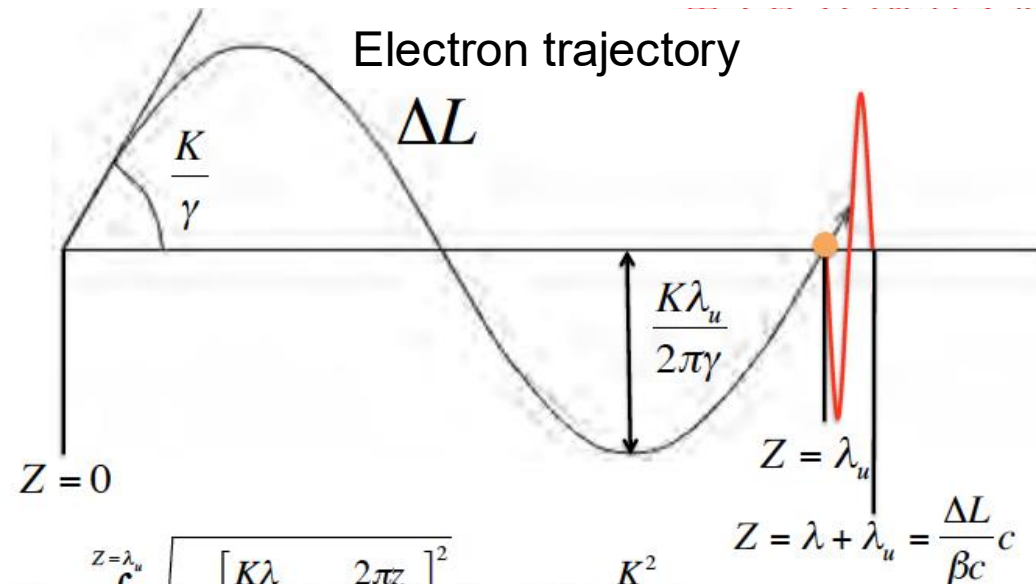

$$\Delta L = \int_{Z=0}^{Z=\lambda_u} \sqrt{1 + \left[ \frac{K\lambda_u}{2\pi\gamma} \sin\left(\frac{2\pi z}{\lambda_u}\right) \right]^2} dz \approx \lambda_u \left( 1 + \frac{K^2}{4\gamma^2} \right)$$

# Self-Amplified Spontaneous Emission

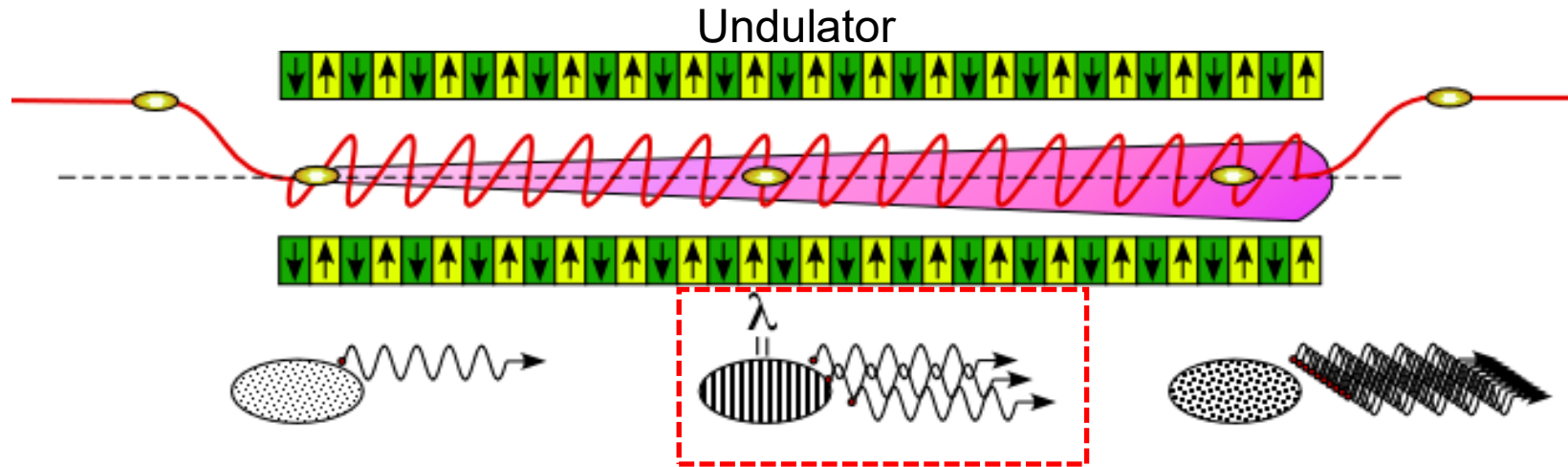

Light overtakes electrons by one wavelength for every one undulation period

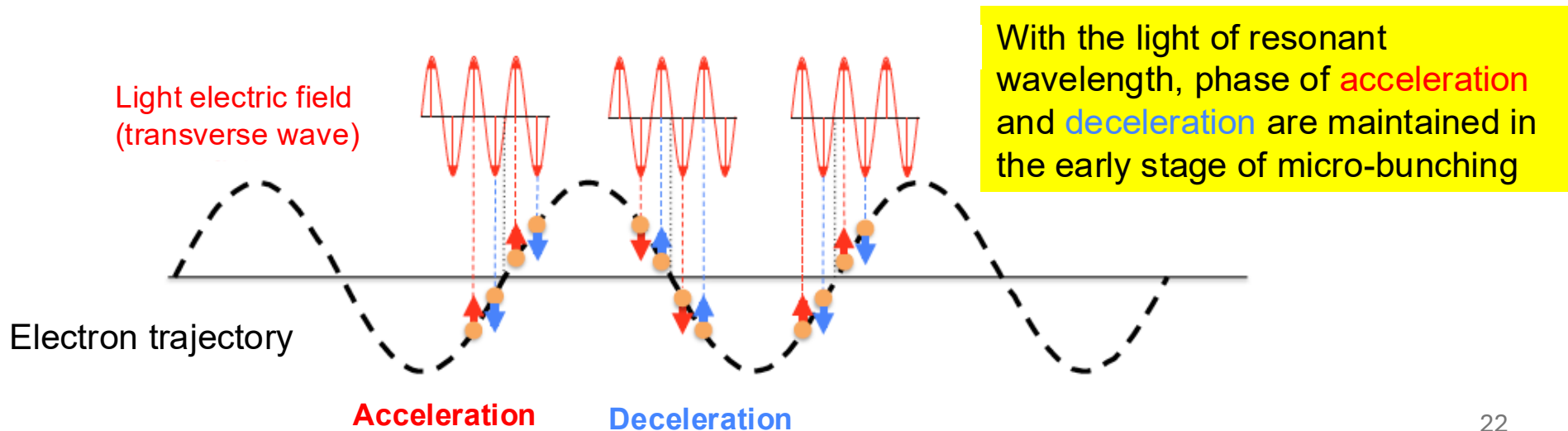

# Self-Amplified Spontaneous Emission

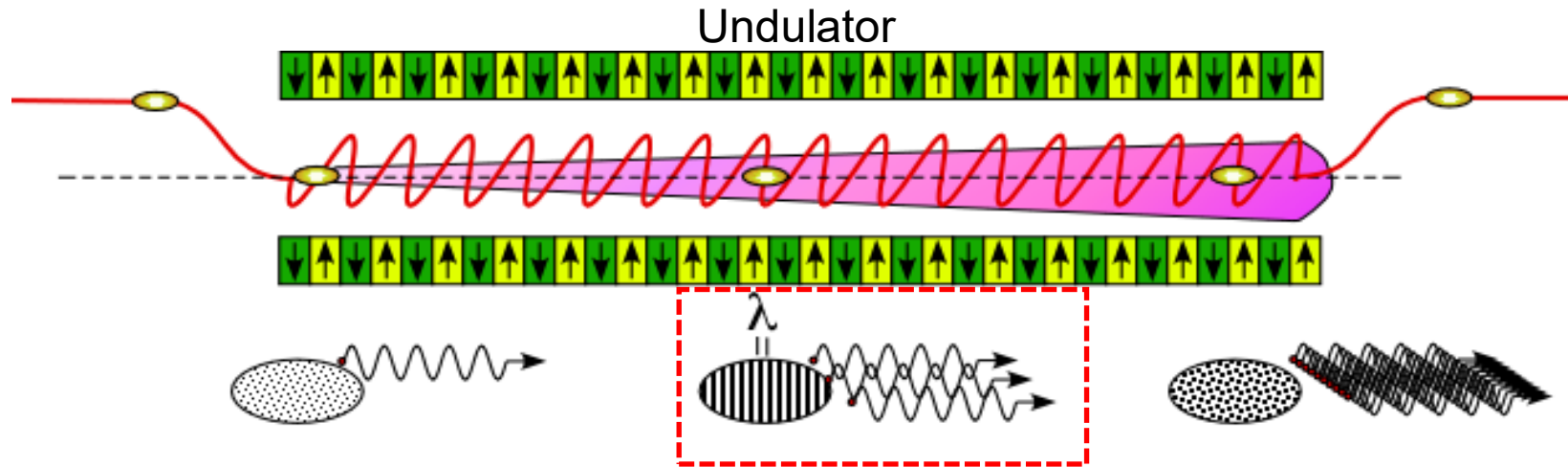

Electrons gaining and losing energy gather towards at the field zero crossing points

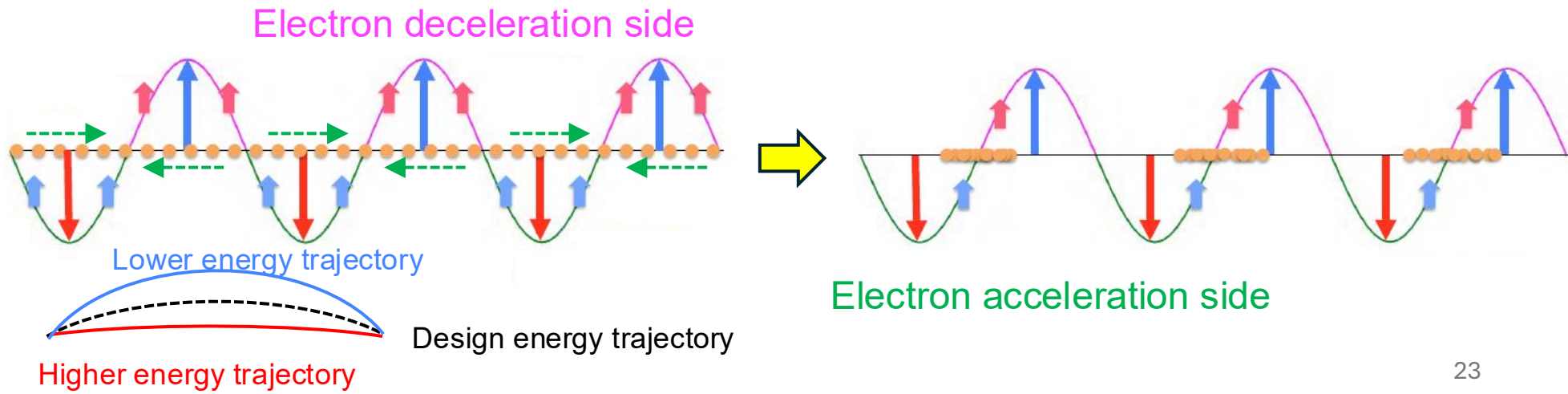

# Self-Amplified Spontaneous Emission

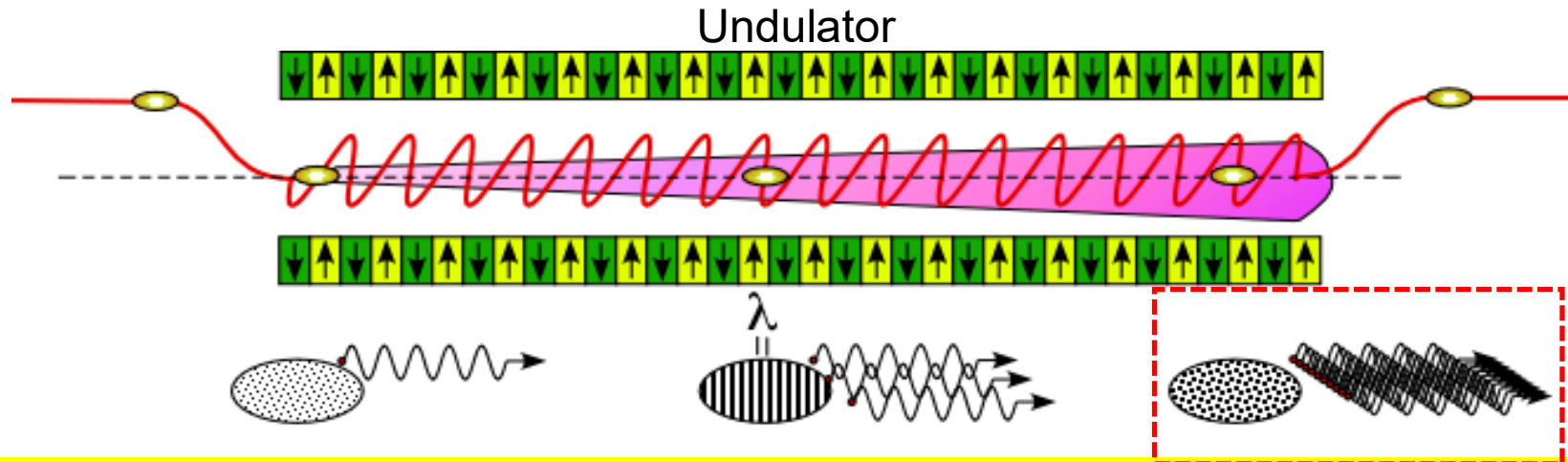

Energy exchange with electrons modulates the phase of light electric field

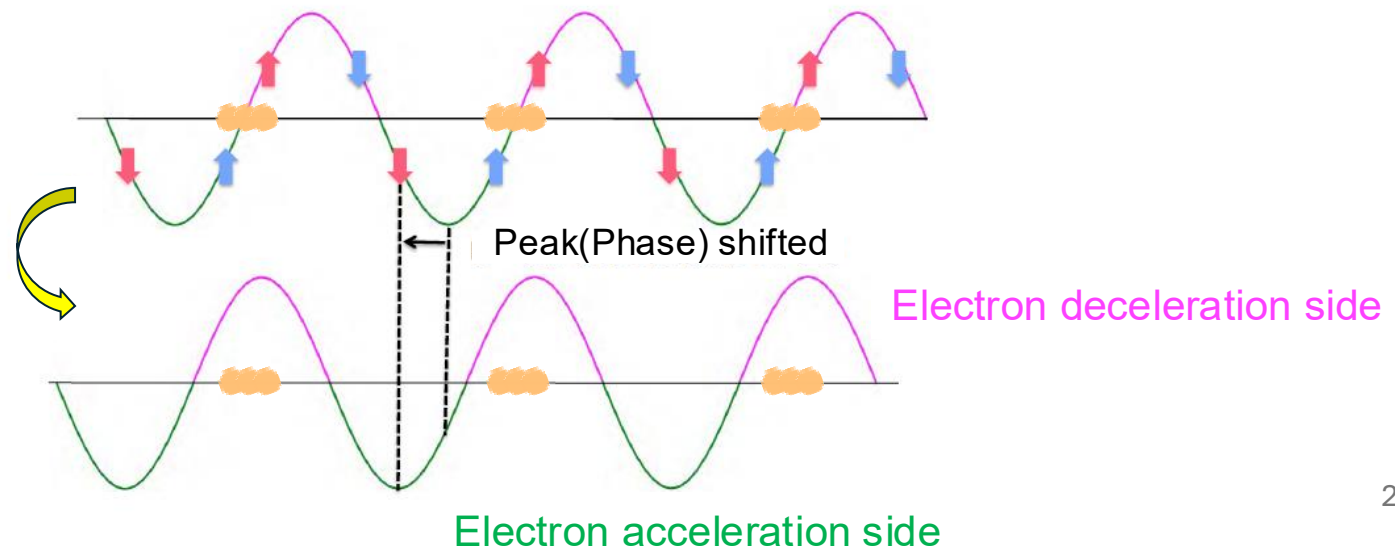

# Self-Amplified Spontaneous Emission

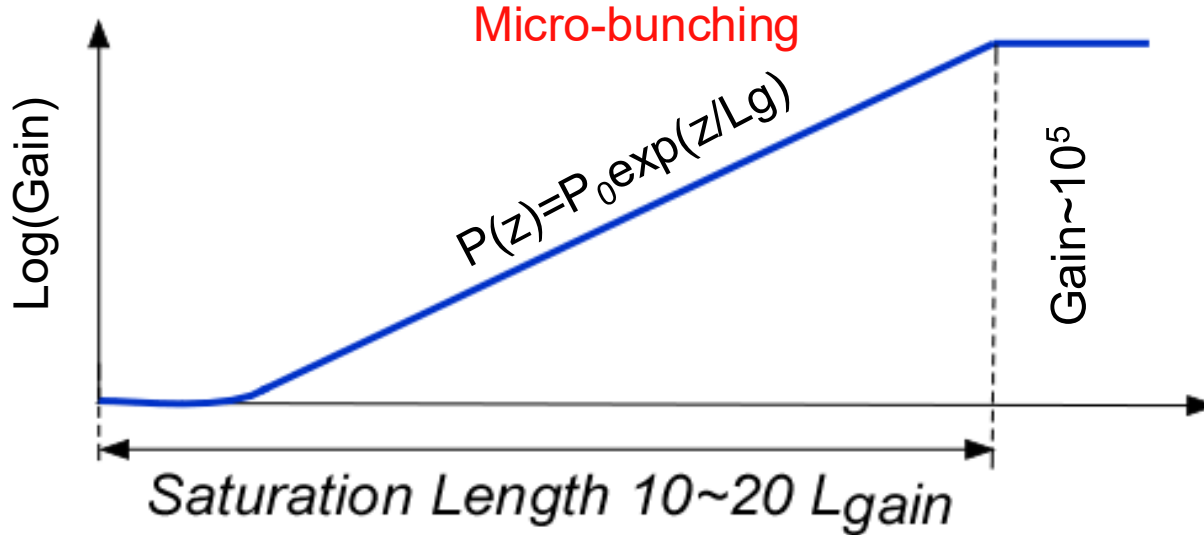
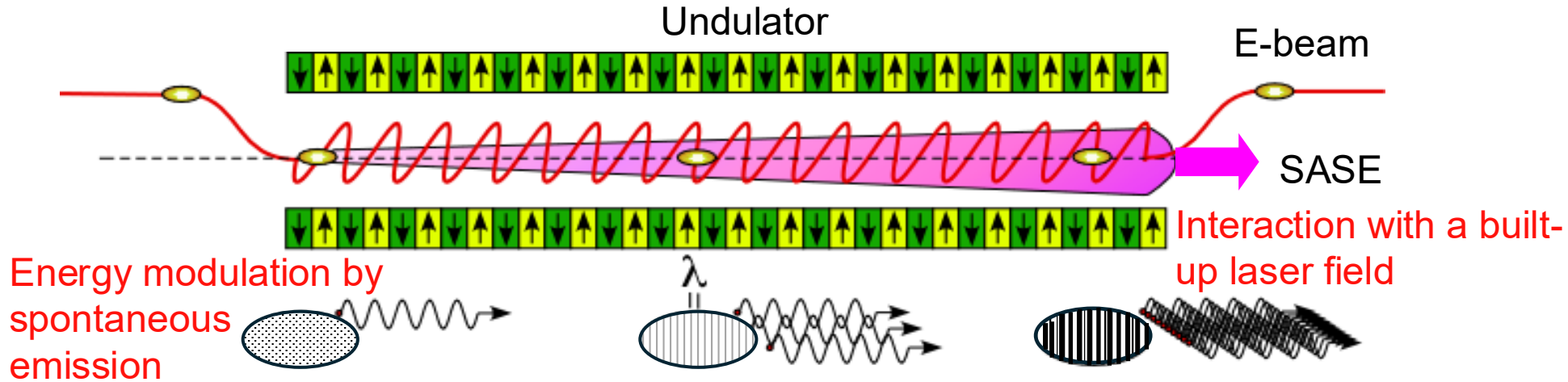

# 1D SASE gain length

The gain length  $L_G$  represents the undulator length enhancing the laser power by a factor of  $e$  (approximately 2.7).

$$P(z) \propto \text{Exp}\left(\frac{z}{L_G}\right),$$

$$L_G = \frac{\lambda_u}{4\pi\sqrt{3}\rho},$$

$$L_G \propto \rho^{-1} \propto \left(\frac{\sigma_x \sigma_y}{I_p}\right)^{1/3} \approx \left(\frac{\langle \beta \rangle \epsilon_s}{I_p}\right)^{1/3}$$

Averaged beta over the undulator

Emittance at the lasing slice

Peak current at the lasing slice

# Single-pass FEL system

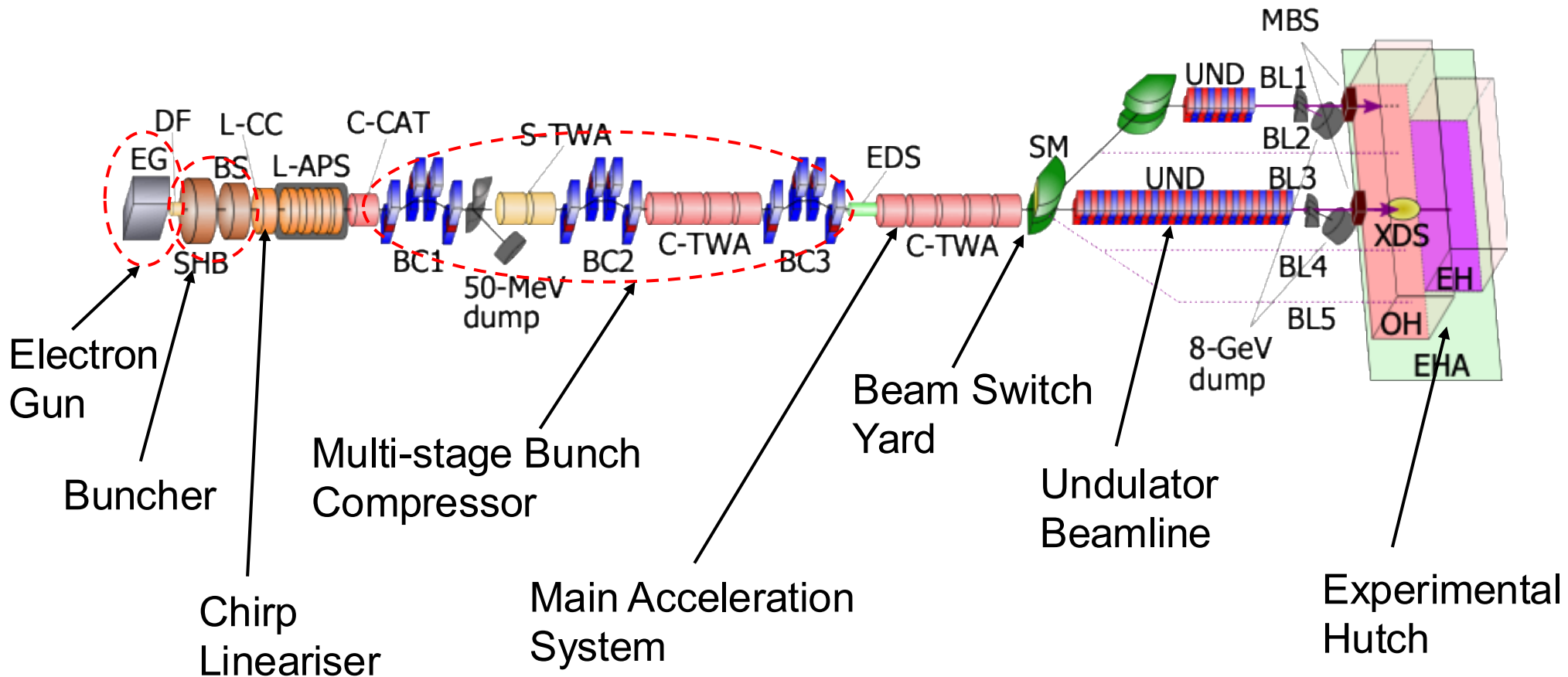

T. Ishikawa et. al., *Nat. Photon.* **6** (2012) 540-544

# High repetition rate XFEL based on superconducting linac (mainstream)

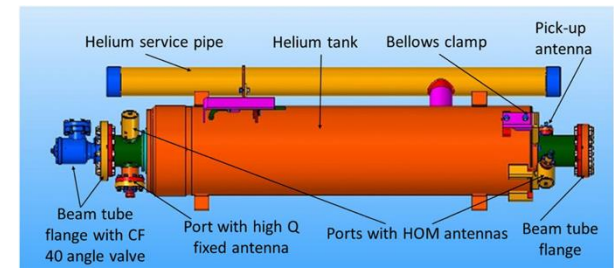
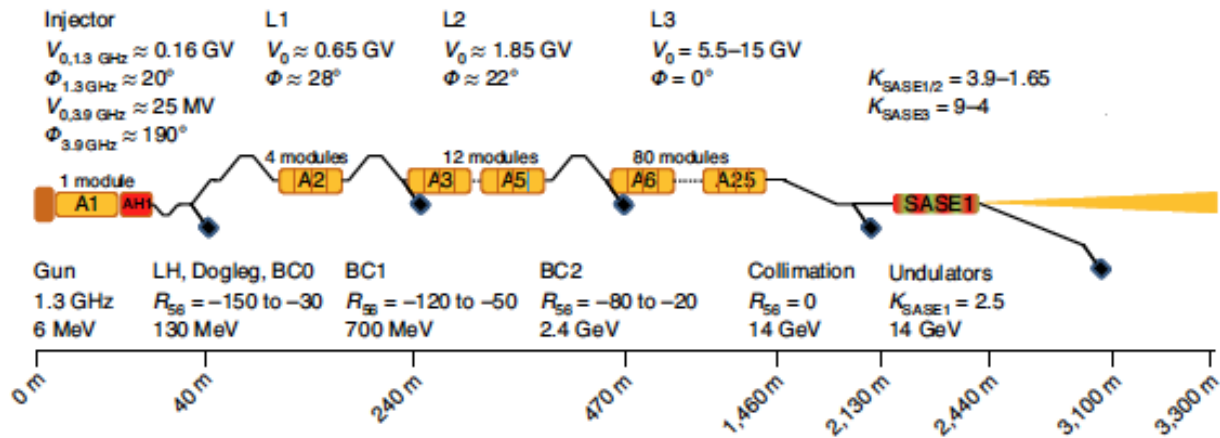

(a)

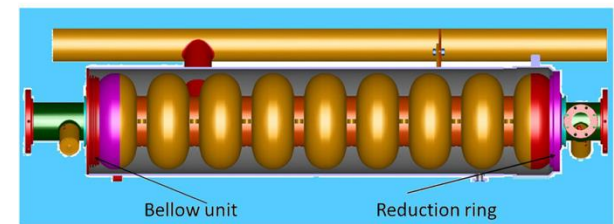

(b)



W. Decking et. al., *Nat. Photon.* **14** (2020) 391-397

# SPring-8 Compact SASE Source (SCSS)

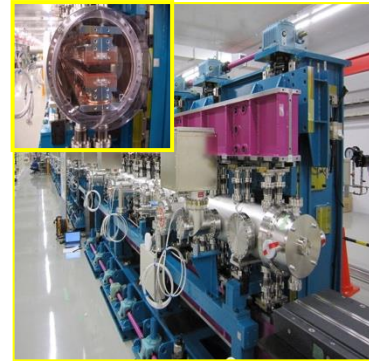
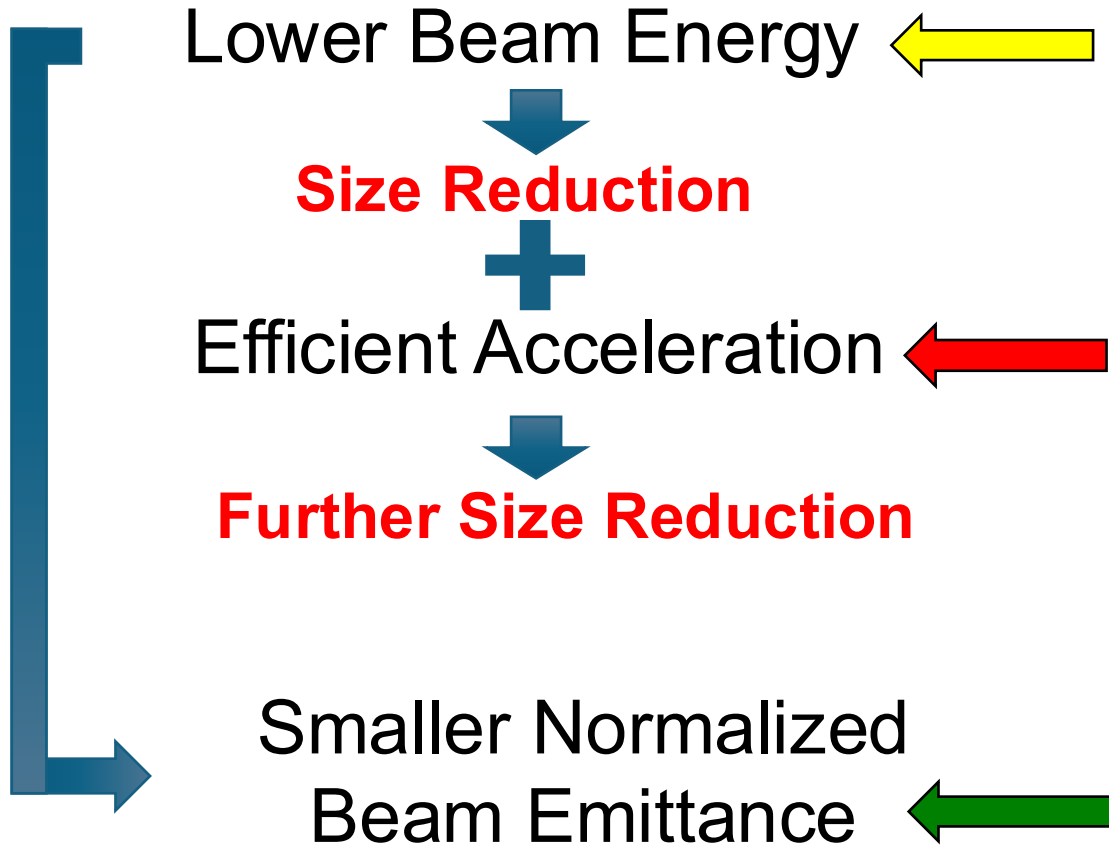

Short period in-vacuum undulator



C-band high gradient acceleration system



Thermionic gun based low emittance injector

T. Ishikawa et. al., *Nat. Photon.* **6** (2012) 540-544

# Variety of XFELs

1. Two-color FEL
2. Self-seeded FEL
3. Circular-/linear-polarized FEL
4. **Extremely short-pulsed FEL**

# Two-color XFEL with wide tunability

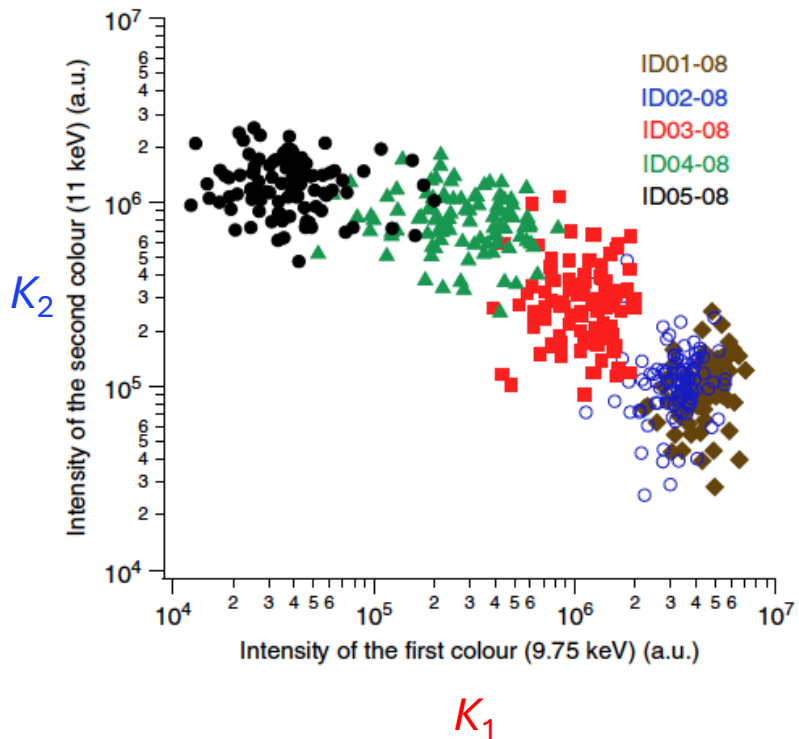
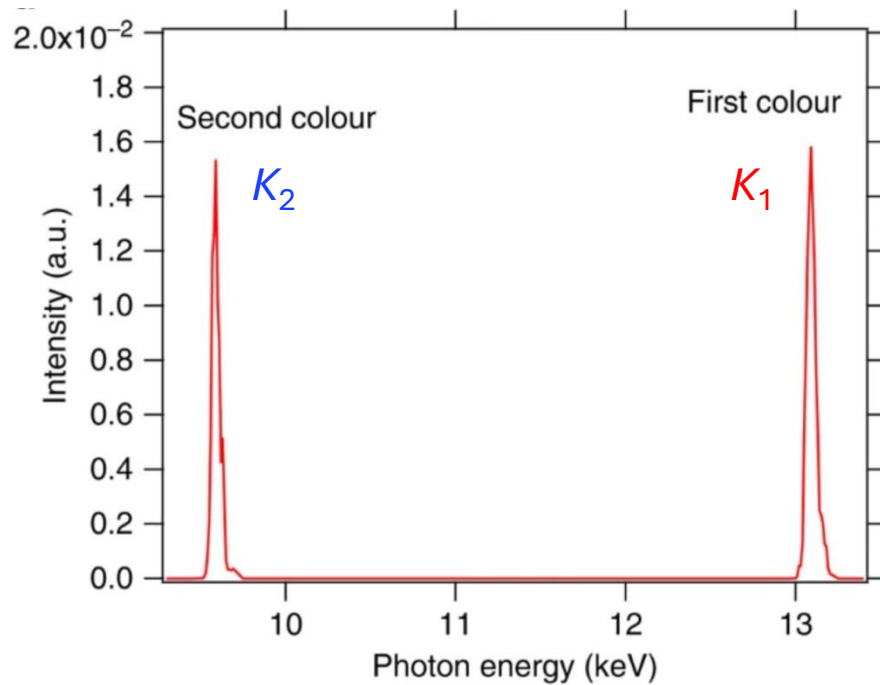
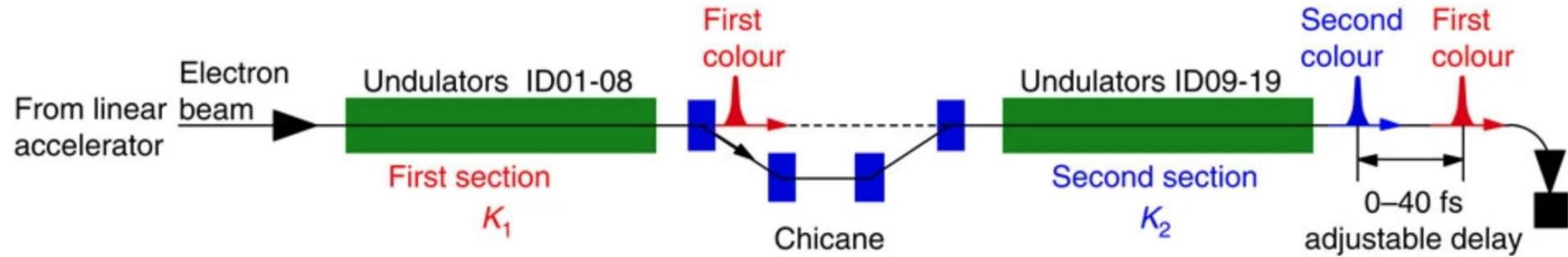

# Self-seeding with reflective geometry

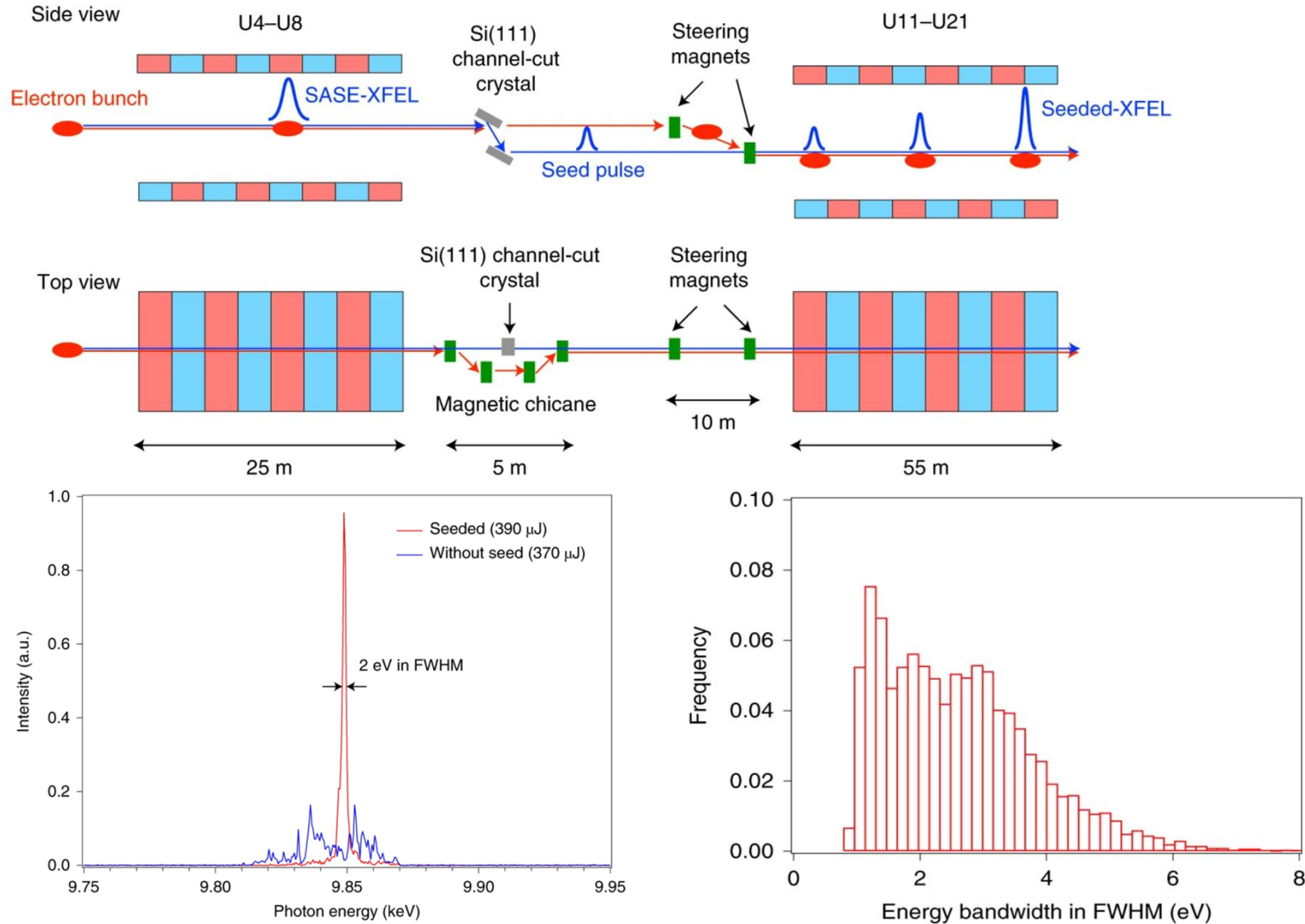

# Circular-polarization XFEL

XPR(X-ray phase retarder)

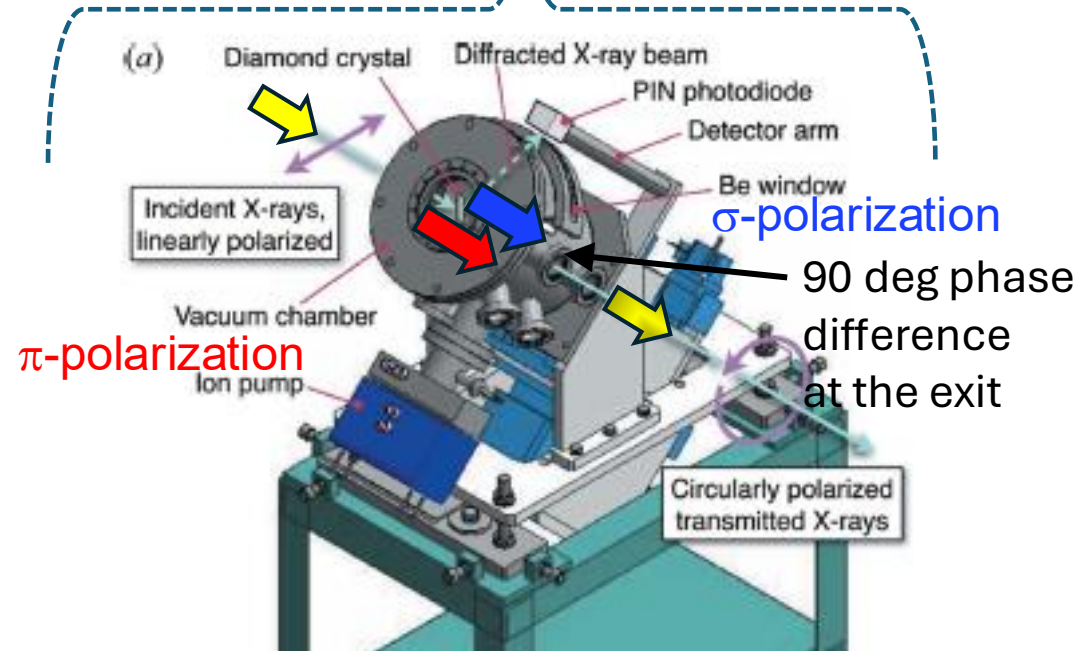
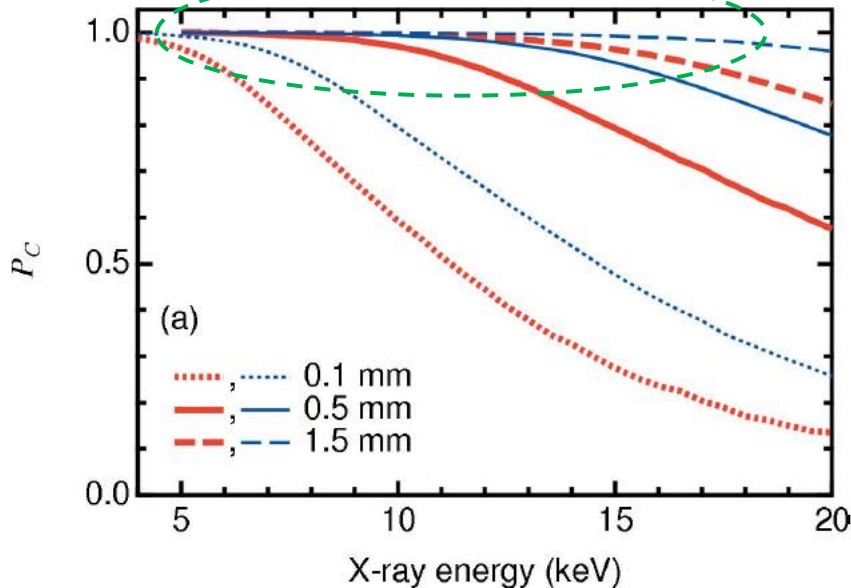
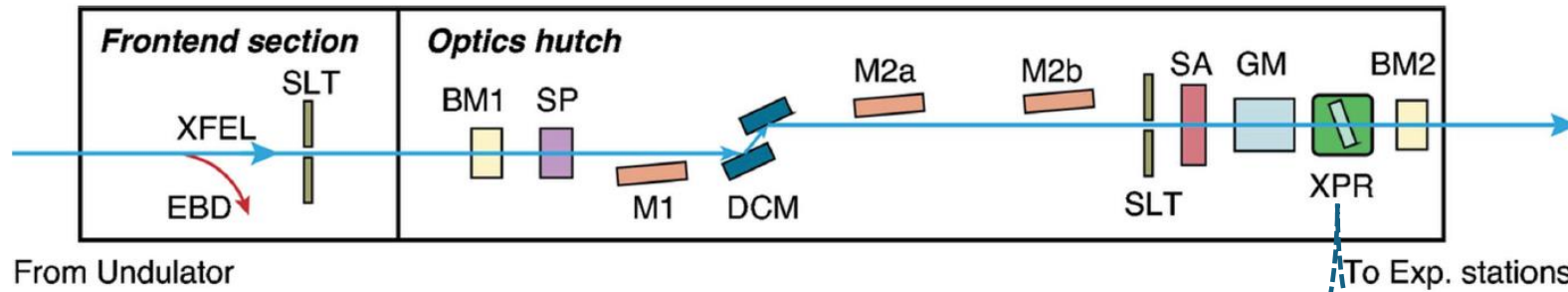

1. History of synchrotron radiation source development
2. Diffraction-limited SR sources
3. Single-pass free-electron lasers
4. Future development direction with a few topics

# Post diffraction limited SR

## - Longitudinally coherent x-ray generation-

The diffraction limited condition means the X-ray brilliance by undulator radiation is no longer enhanced even when natural emittance is reduced.

To dramatically increase the brilliance, **paradigm-shift** from “spontaneous radiation” to “longitudinally coherent radiation” is required.

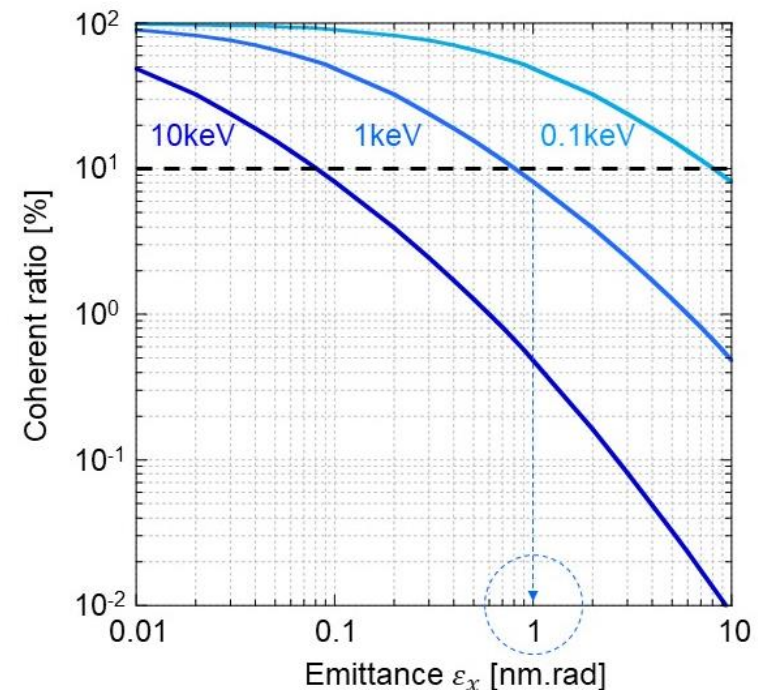

# Cavity-based FEL in a diffraction-limited SR

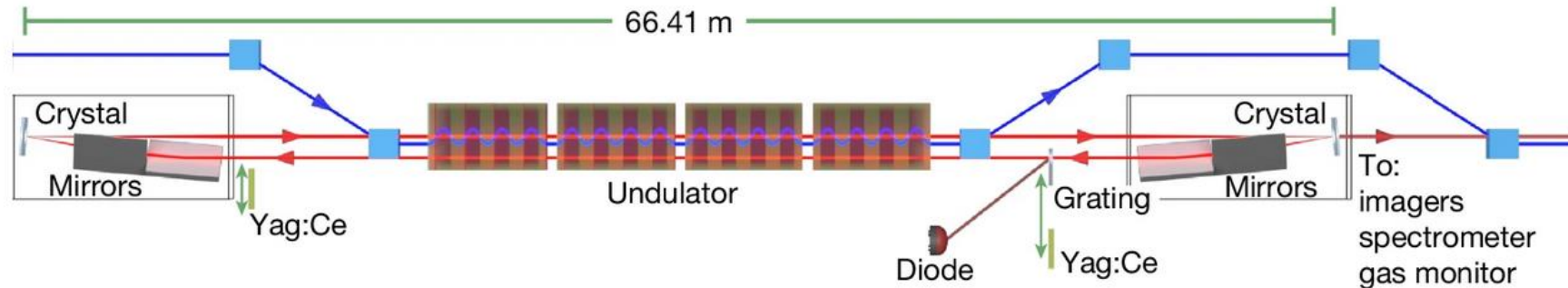

The first proof-of principle Experiment was performed at the SASE1 undulator line of the European XFEL. The X-ray cavity consists of two diamond crystals in Bragg reflection working close to backscattering geometry. The elements in the retro-reflector are aligned such that the beam after reflection returns at a distance of 2.67 mm from the incident beam inside the same vacuum pipe. The downstream retro-reflector unit (on the right) is adjustable to tune the cavity length. The electron beam (blue) is injected from the left using a magnetic chicane, and the X-ray pulse (red) is circulating in the cavity, overlapping with electron bunches that pass the undulator at 2.23 MHz.

# Towards brilliant atto-second X-ray generation

A frontier of practical “single” atto-second brilliant X-rays remains.

- 1) Tuesday 19th afternoon: “Attsecond FEL Physics” by Agostino Marinelli (SLAC)
- 2) Thursday 21<sup>st</sup>, morning: “Generation of tunable sub-femtosecond XFEL pulses by electron bunch recompression using reverse-energy chirp” by Kenji Yasutome (RIKEN)

# Towards brilliant atto-second X-ray generation

A frontier of practical “single” atto-second brilliant X-rays remains.

1) ESASE(Enhanced SASE) scheme

[A. Zholents and W. Fawley, \*PRL\* 92, 224801 \(2004\)](#); [A. Zholents and G. Penn, \*PRAB\* 8, 050704 \(2005\)](#); [A. Zholents, \*PRAB\* 8, 040701 \(2005\)](#); [E. Saladi et. al., \*PRAB\* 9,050702 \(2006\)](#); [Y. Ding et. al., \*PRAB\* 12, 060703 \(2009\)](#); [J. Duris et. al., \*Nat Photon\* 14, 30-36 \(2020\)](#)

2) Slotted foil scheme

[P. Emma et. al., \*PRL\* 92, 074801 \(2004\)](#); [A. Marinelli et. al., \*APL\* 111, 151101 \(2017\)](#)

3) ESASE seeding scheme [T. Tanaka, \*PRL\* 110, 084801 \(2013\)](#)

4) Hard bunch compression scheme

[S. Huang et. al., \*PRL\* 119, 154801 \(2017\)](#); [E. Prat et. al., \*APL Photonics\* 8, 111302 \(2023\)](#); [E. Prat et. al., \*PRRes\* 7, L042060 \(2025\)](#)

5) Scheme using a reverse-chirp due to a space charge force

[J. Yan et. al., \*Nat Photon\* 18, 1293-1298 \(2024\)](#)

6) Scheme using slippage over the undulator [T. Tanaka, \*PRL\* 114, 044801 \(2015\)](#)

# ESASE(Enhanced SASE) scheme

$\lambda_L = 800 \text{ nm}$ ,  $P_L = \sim 6 \text{ GW}$ ,  $\tau_L = \sim 5 \text{ fs}$

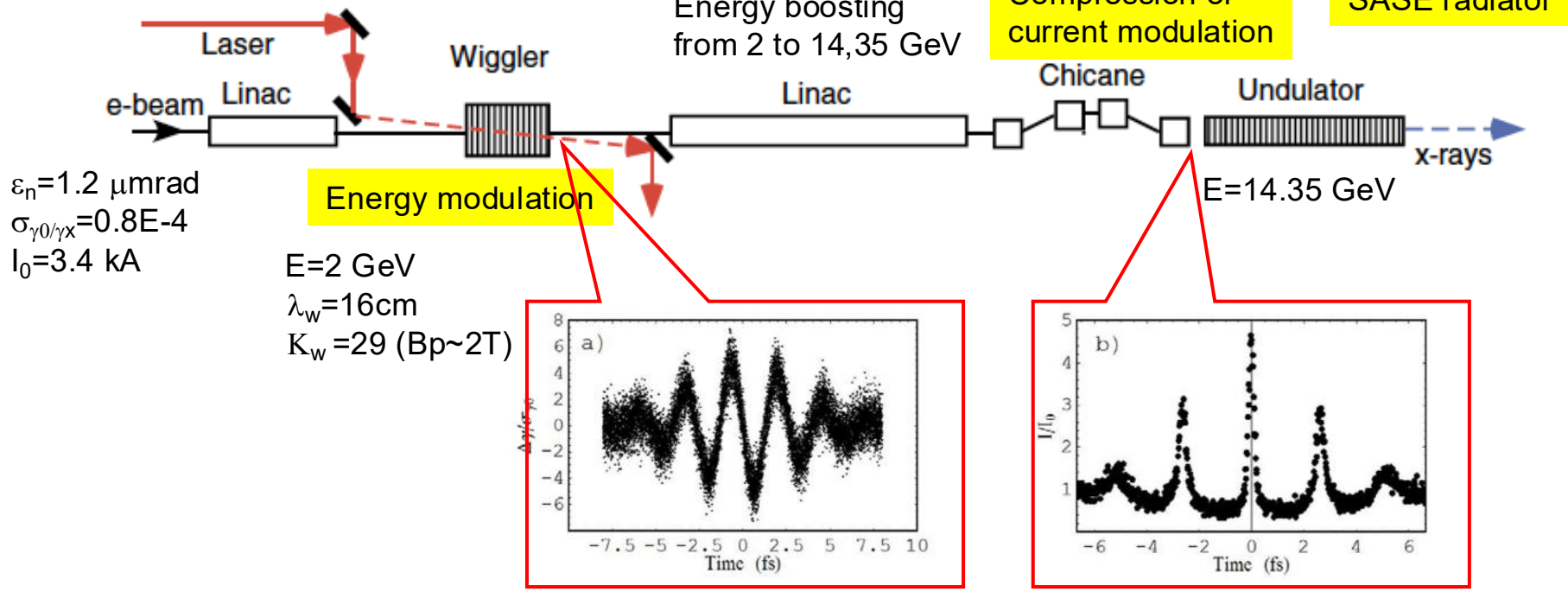

- Energy modulation by a high-power short-pulsed laser at the wiggler section
- Converting the energy modulation to the density modulation at the chicane with help of R56(bunch compression)
- Extracting a sub-femtosecond XFEL pulse from the largest current spike

A. Zholents, *PRAB* 8, 040701 (2005).

# Slotted foil scheme

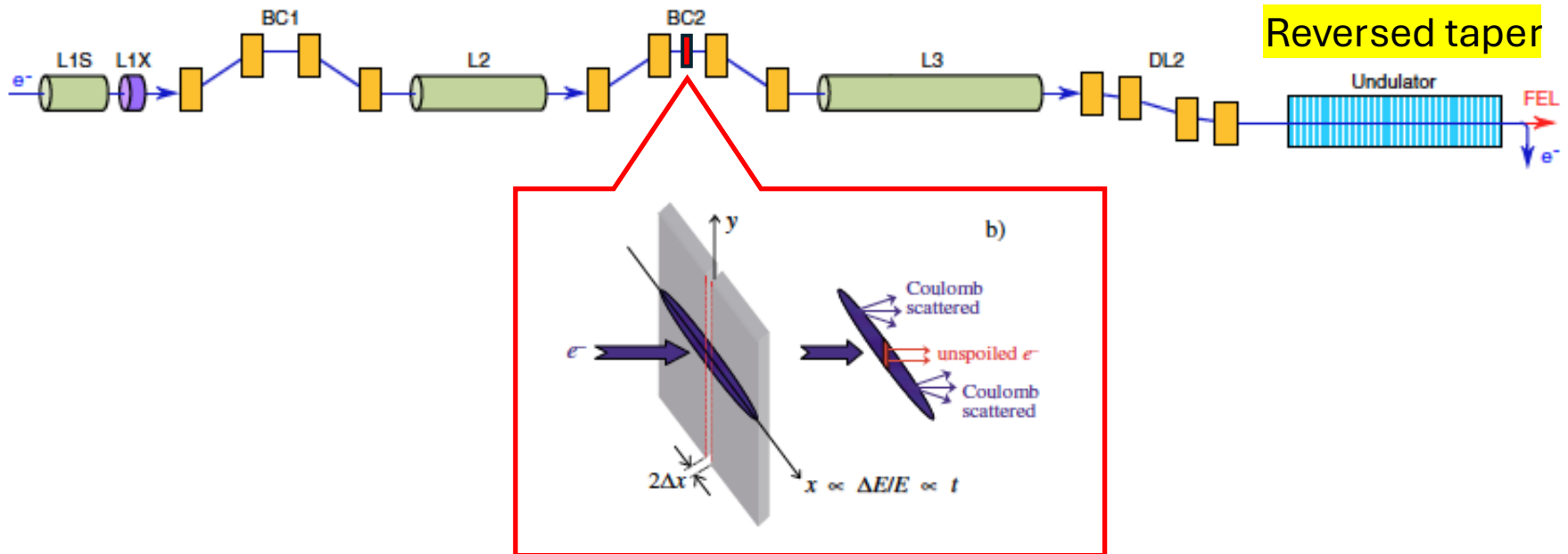

- Simple scheme
- Control the lasing beam slice into a short pulse duration
- Low electron charge -> **difficult to access high peak power**

# ESASE seeding scheme

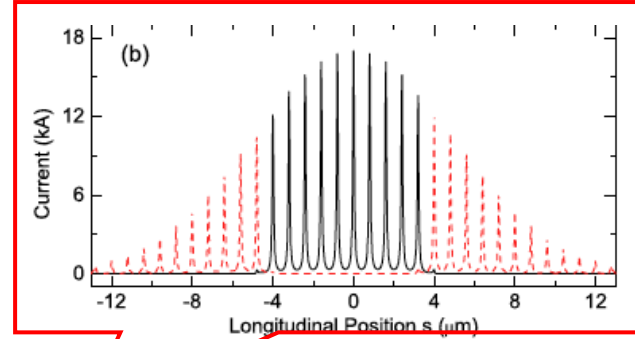
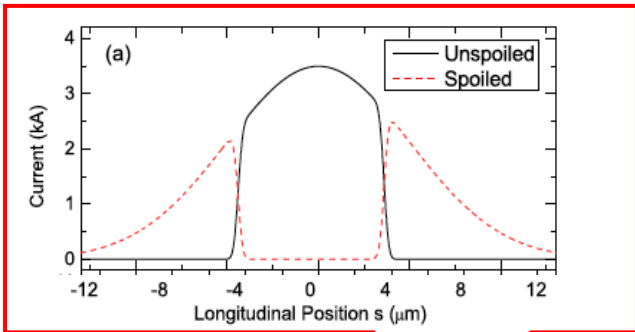

$E=8$  GeV  
 $\epsilon_n=0.7$   $\mu\text{mrad}$   
 $\sigma_{\gamma 0/\gamma X}=1$  E-4  
 $I_0=3.5$  kA

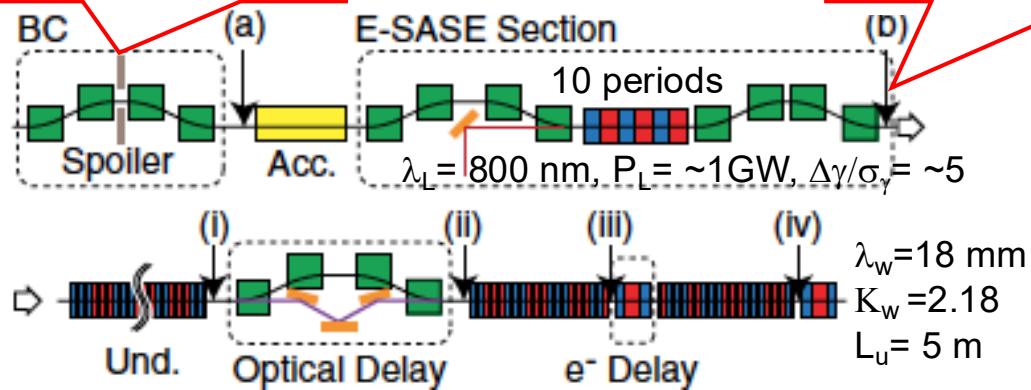

This scheme enables 1) **high peak laser power up to several TW** and 2) **pure single attosecond XFEL pulse**  
**Demerit: too complicated system**

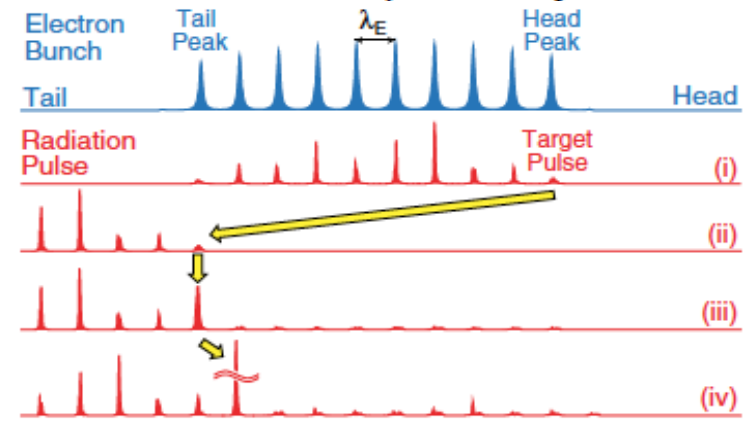

- Generating a series of electron density spikes by a ESASE process with slotted foil
- Generating a seed laser by a undulator radiator
- Adjusting seed laser timing to the tail electron peak
- Enhancing seed laser intensity
- Adjusting the next upstream peak timing to seed laser

# Hard bunch compression scheme

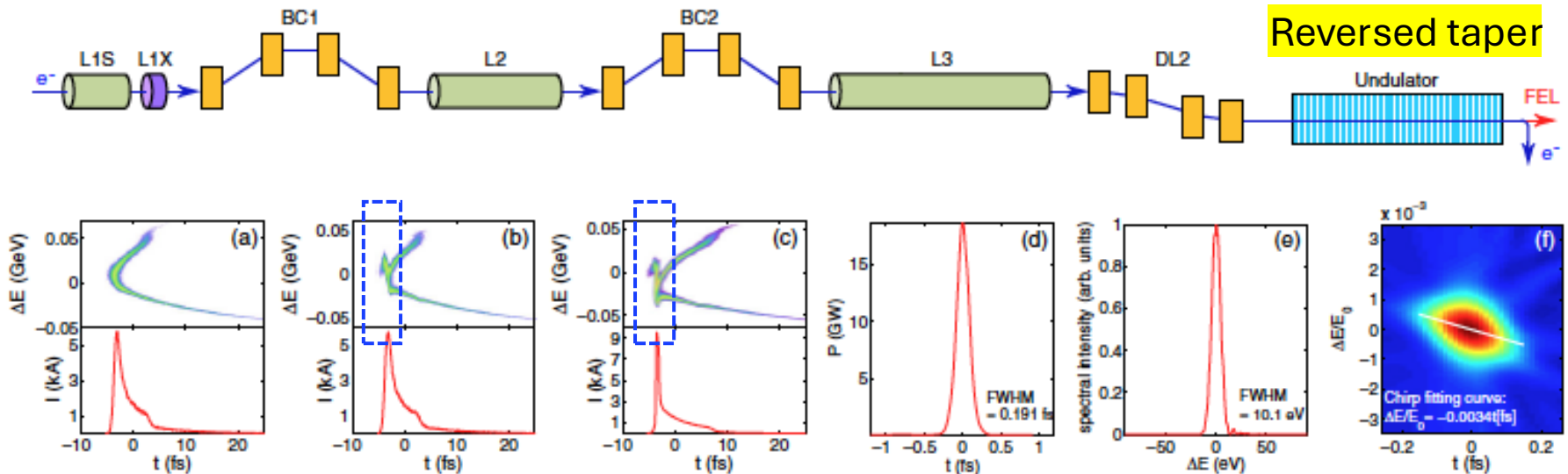

- Low charge of 20 pC -> **difficult to access high peak power**
- Nonlinear hard bunch compression -> peaky peak
- Shortening XFEL pulse by limiting lasing only at the reverse chirp part by using the undulator reverse taper

# Scheme using a reverse-chirp due to a space charge force

Additional bunch compression with positive R56

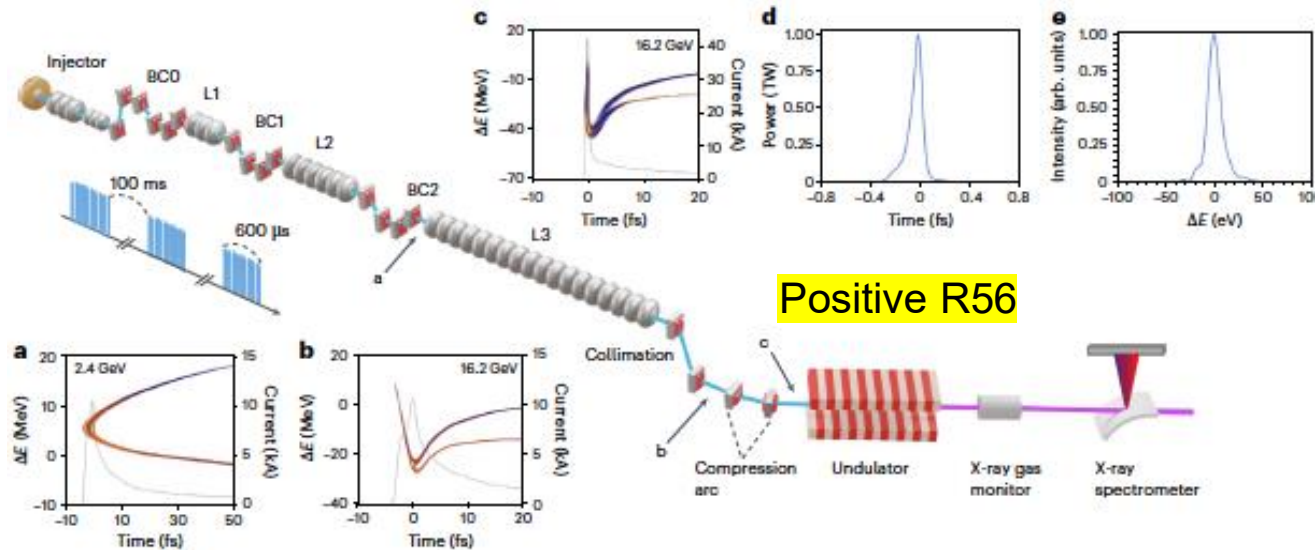

Normal energy chirp    Reverse energy chirp

- Self-energy chirp modulation due to SPC -> rather stable operation
- Reverse-energy chirped electron bunch compressed using a positive R56 dogleg
- Small emittance degradation by bunch compression at higher electron energy
- Not optimized dogleg -> **difficult accelerator parameter tuning**

# Scheme counteracting the slippage effect towards “single attosecond pulse”

Limit of FEL pulse length determined by a period number of “radiator”  
 How do we generate a shorter-pulsed, single attosecond FEL?

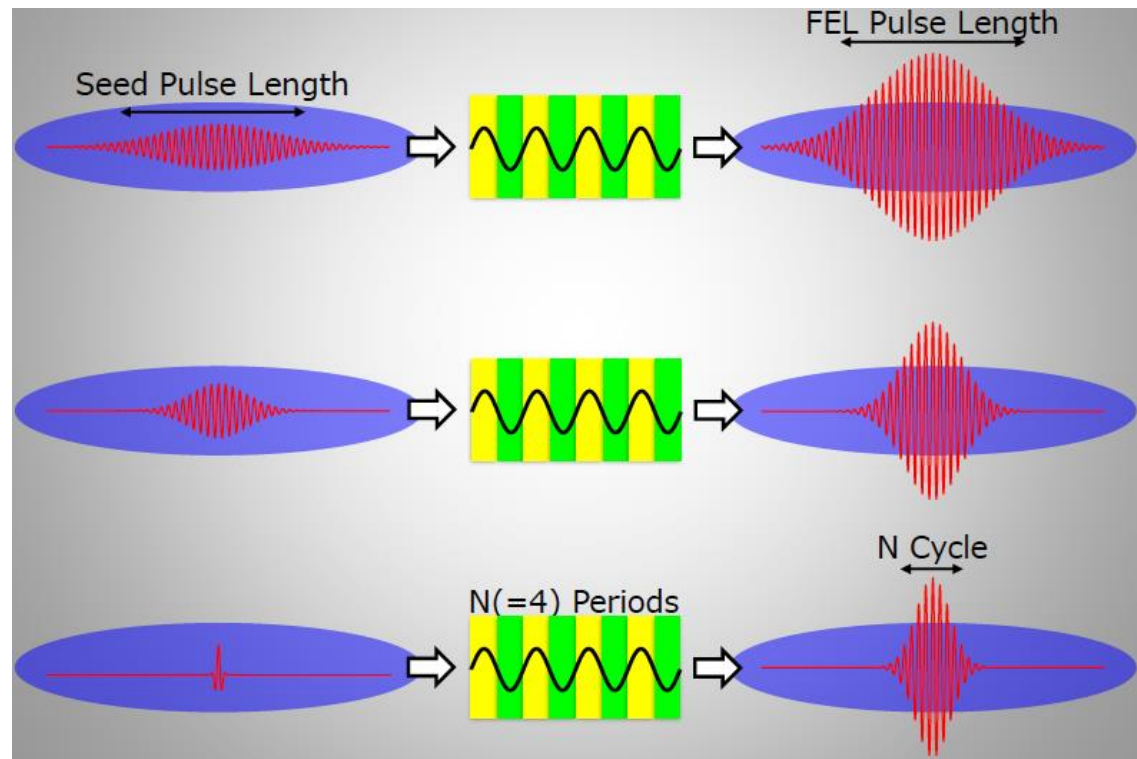

# Scheme counteracting the slippage effect towards “single attosecond pulse”

- Chirped micro-bunching with the separation varied from  $\lambda_1$  to  $\lambda_{10}$
- Ten period tapered undulator with the slippage changing from  $\lambda_1$  to  $\lambda_{10}$
- Dramatic pulse shortening effect by the phase cancellation

Chirped micro-bunching beam

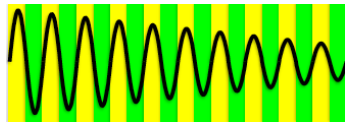

10 period tapered undulator with slippages of  $\lambda_1, \lambda_2, \lambda_3 \dots \lambda_{10}$

Radiation from #1

Radiation from #1+2

Radiation from #1+2+3

Radiation from #1+2+3+4

Radiation from #1+2+3+4  
.....+10

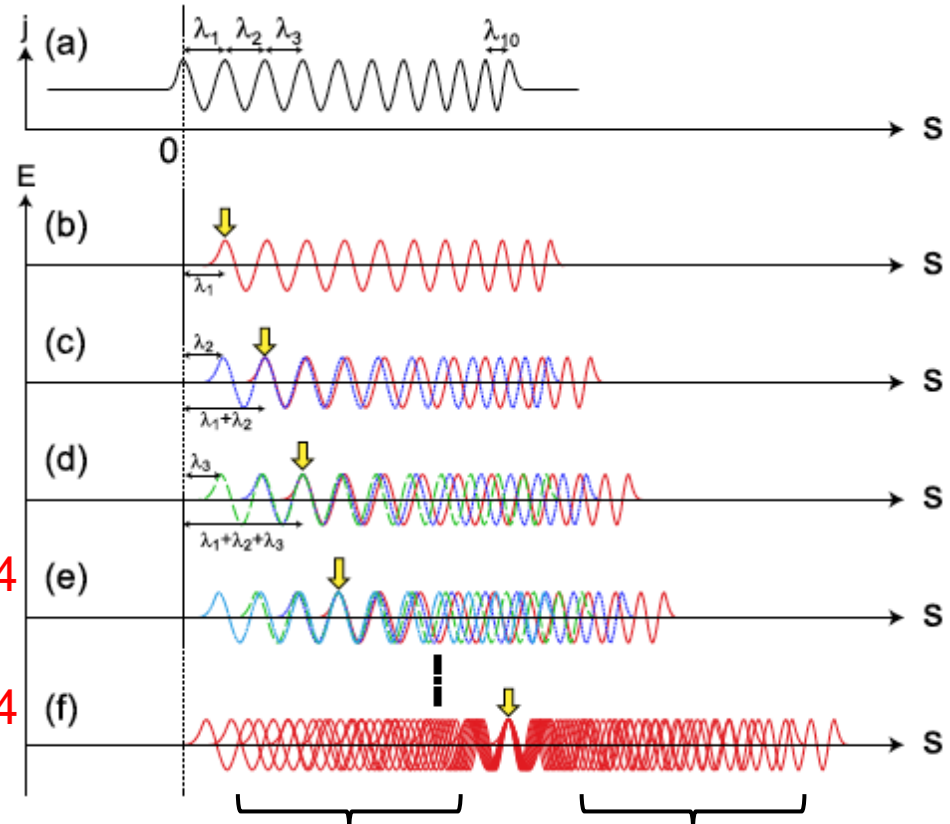

Damped by phase cancellation 45

# Scheme counteracting the slippage effect towards “single attosecond pulse”

Generating single cycle density modulation

