

Colliders and related accelerators

Yannis PAPAPHILIPPOU

Accelerator and Beam Physics group

Beams Department, CERN

IPAC'26 Student tutorials

Deauville, France

May 16th, 2026



- Purpose of colliders
- Colliders' figures of merit
 - c.m. energy and luminosity
- Present-future hadron colliders and their challenges
 - LHC, HL-LHC, FCC-hh
- Present-future e^+e^- colliders and their challenges
 - Circular (SuperKEKb, FCCee, CEPC)
 - Linear (CLIC, LCF, Plasma-Wakefield colliders)
- Future electron-hadron colliders and their challenges
 - EiC, LHeC
- Future muon collider and its challenges

Purpose of colliders

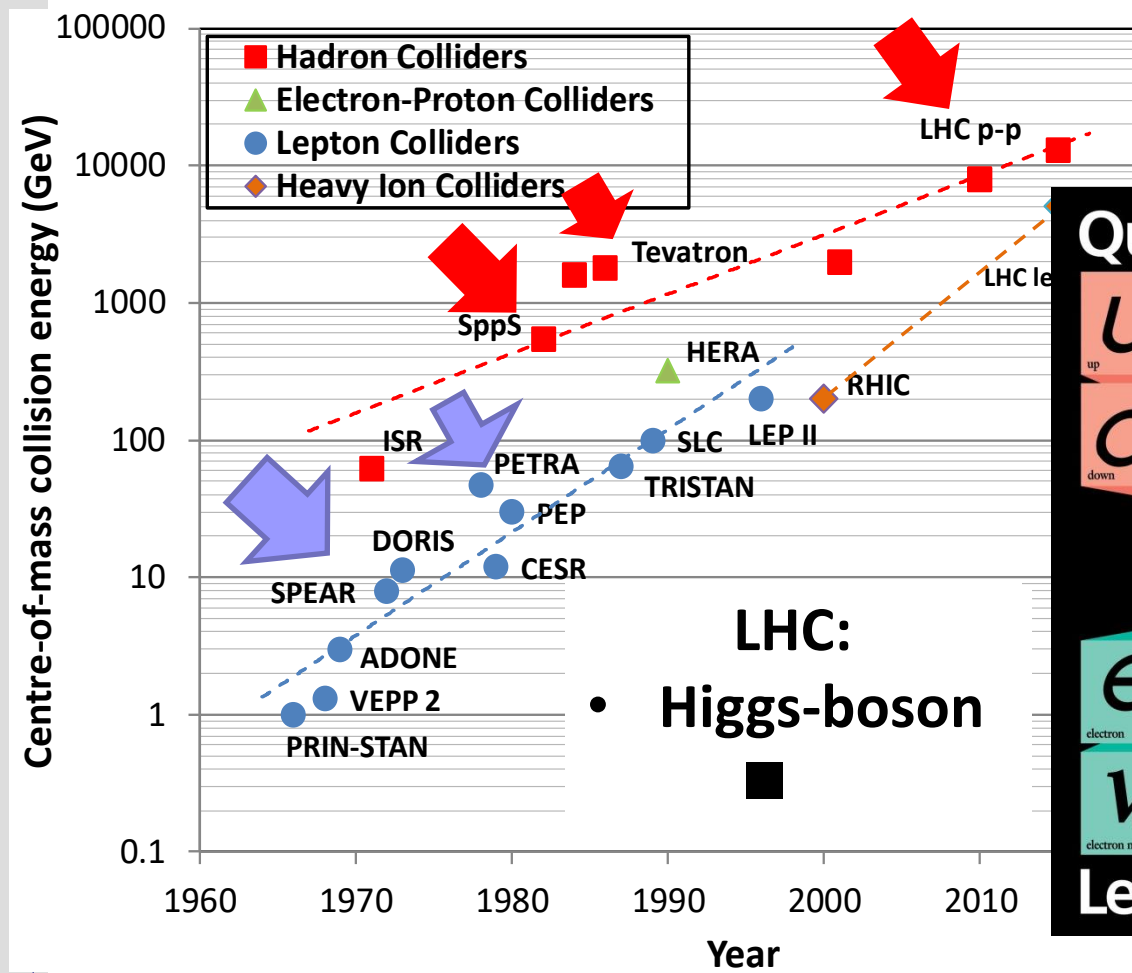

**Standard Model
Particles and forces**

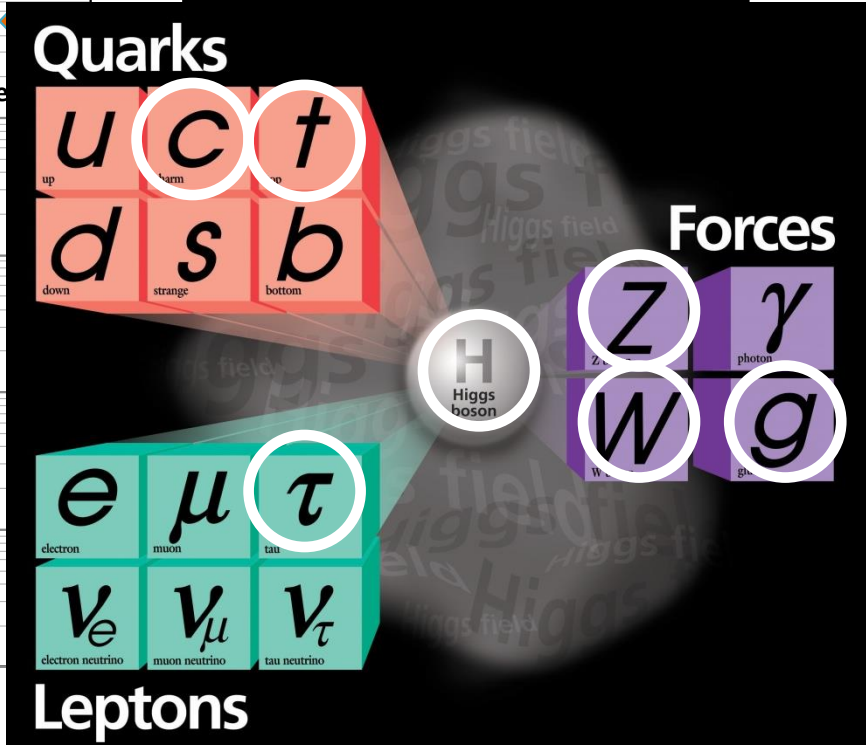

Colliders are powerful instruments in High Energy physics for particle discoveries and precision measurements

- Standard model describes known matter, i.e. 5% of the universe!

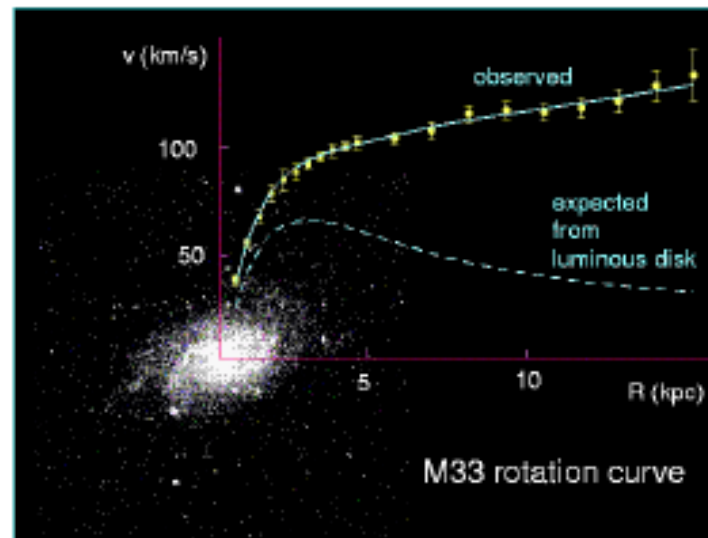
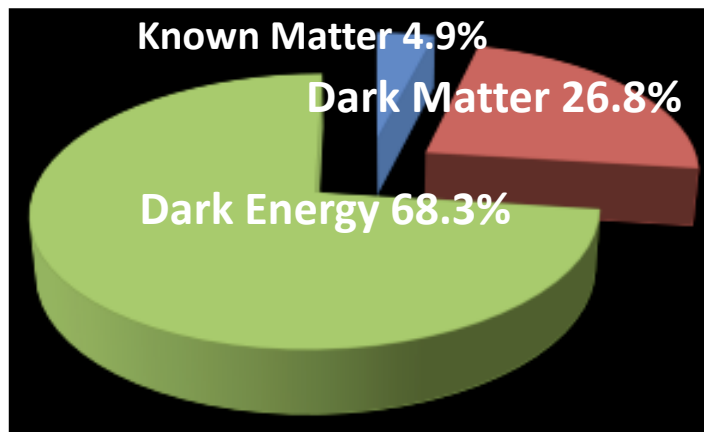

galaxy rotation curves, 1933 - Zwicky

- what is dark matter?
- what is dark energy?
- why is there more matter than antimatter?
- why do the masses differ by more than 13 orders of magnitude?
- do fundamental forces unify in single field theory?
- what about gravity?
- Is there a “world equation – theory of everything”? ...

Colliders' figures of merit

- Figure of merit: **c.m. energy** and **luminosity**

$$E^* \approx \sqrt{2E_A mc^2}$$

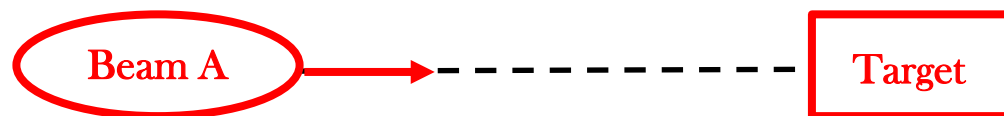

$$E^* = E_A + E_B$$

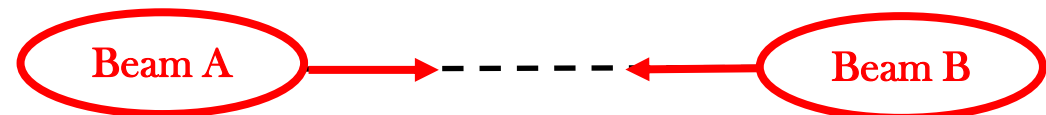

- Figure of merit: **c.m. energy** and **luminosity**
- **Higher energy** means larger size (particularly for hadrons)
- Drives key **technologies: magnets (high-field), RF cavities (high-gradient),...**

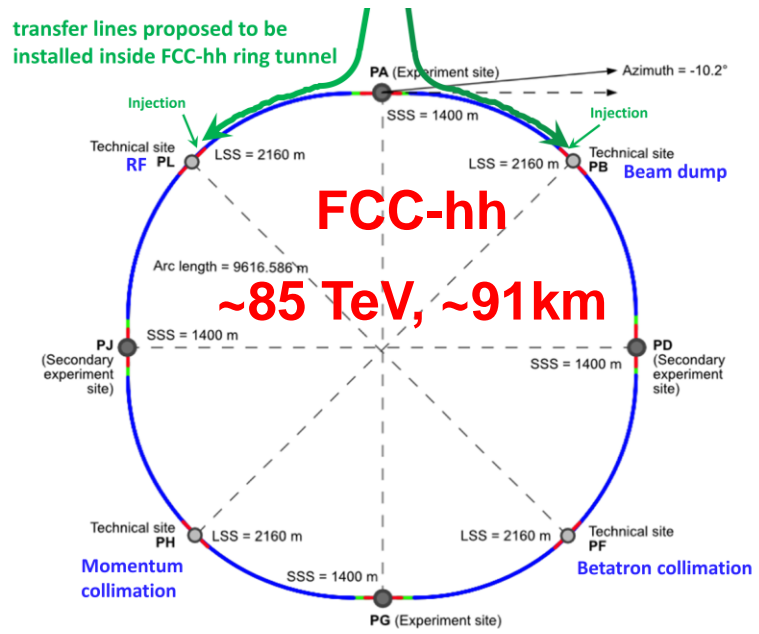

$$E^* \approx \sqrt{2E_A mc^2}$$

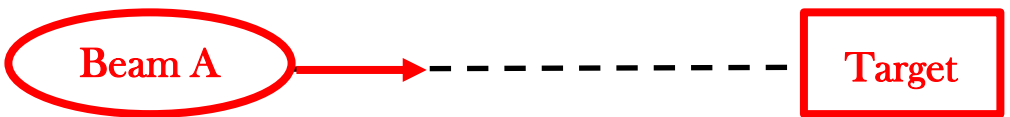

$$E^* = E_A + E_B$$



- Figure of merit: **c.m. energy and luminosity**
- **Higher energy means larger size** (particularly for hadrons)
- Drives key **technologies: magnets (high-field), RF cavities (high-gradient),...**
- “Livingston chart” energy vs time shows succession of **principles/technologies** pushing energies over time (1.5 orders of magnitude/decade)
- Present state of the art **no longer supports past exponential growth** in particle energy

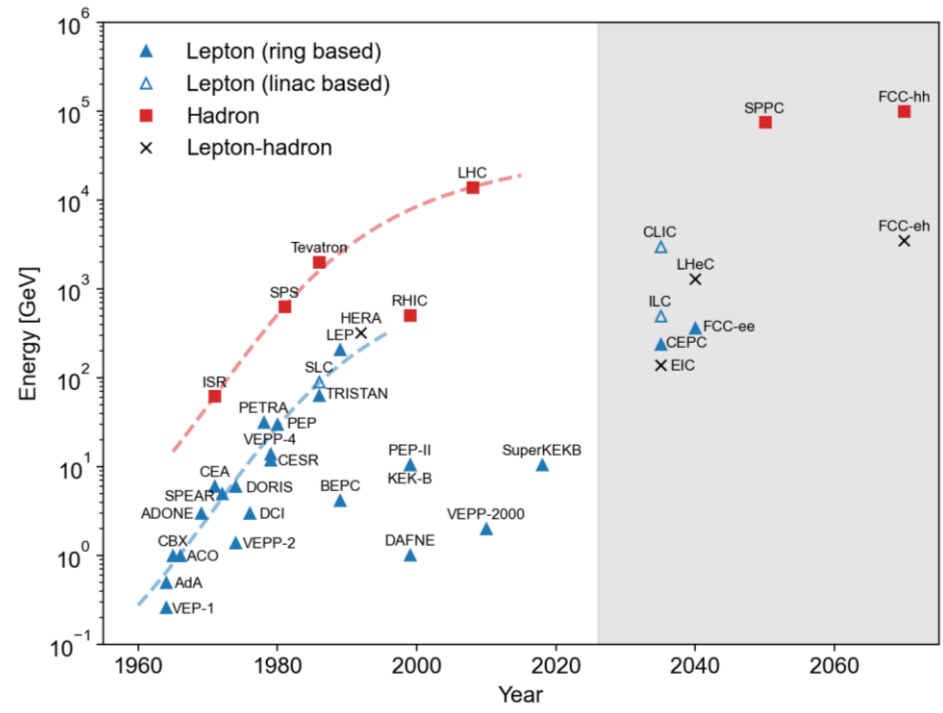

$$E^* \approx \sqrt{2E_A mc^2}$$

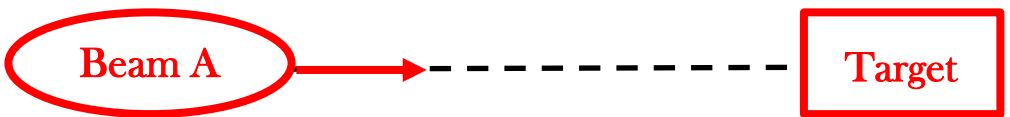

$$E^* = E_A + E_B$$

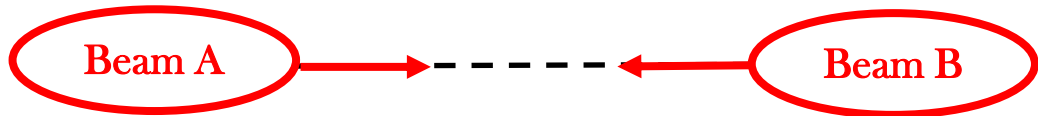

- **Luminosity**: rate of particle production, i.e. **proportionality** factor connecting **number of events** per unit time $\frac{dR}{dt}$ and **cross section** σ_p

$$\frac{dR}{dt} = \mathcal{L} \sigma_p$$

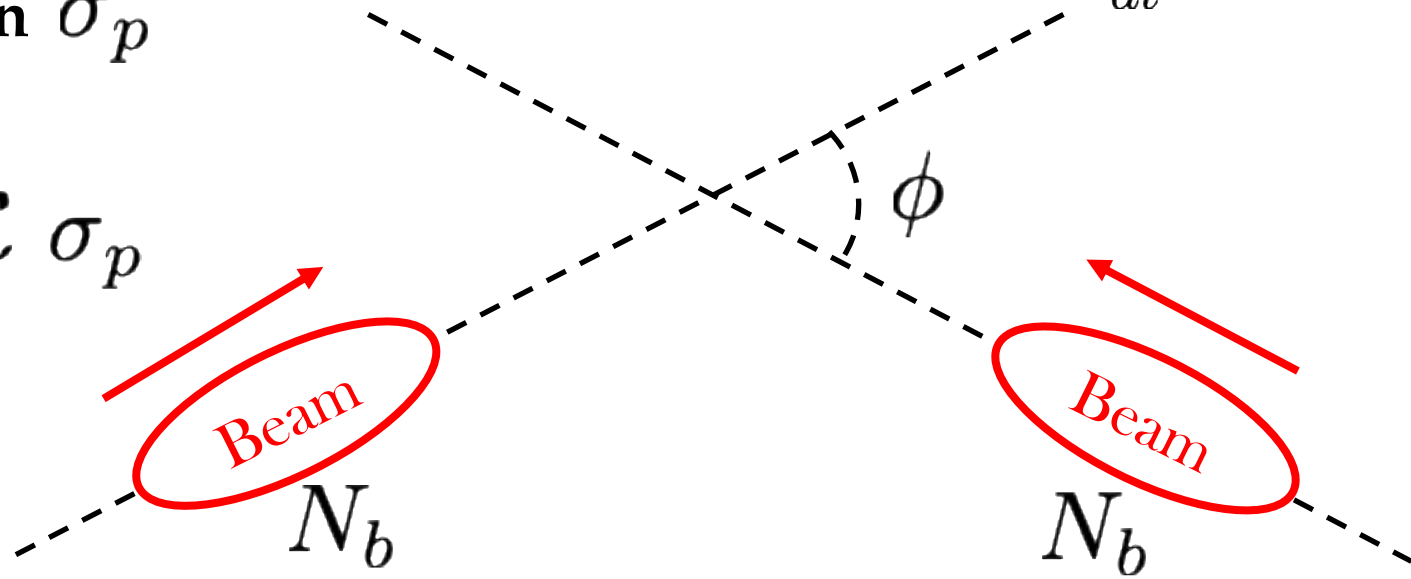

$$\frac{dR}{dt} = \mathcal{L} \sigma_p$$

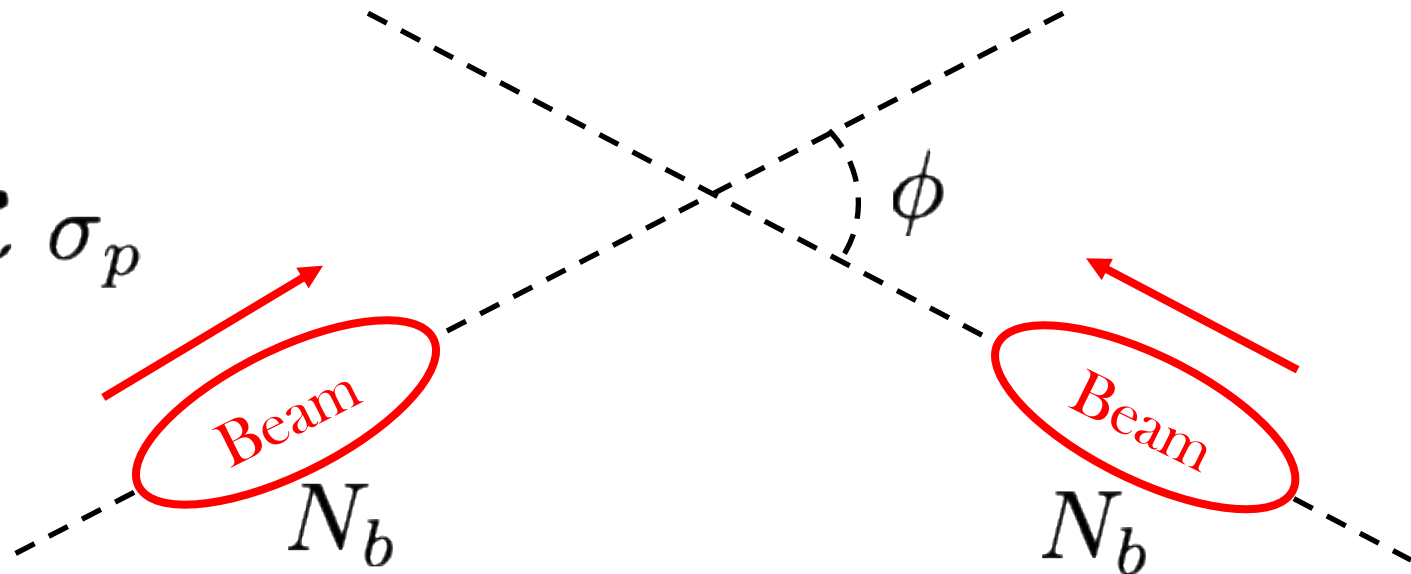

■ **Luminosity** for two identical “round” Gaussian colliding beams

- N_b **bunch population**
- k_b **number of bunches**
- f_{rev} **the revolution frequency**
- γ **relativistic reduced energy**
- ϵ_n **normalized emittance**
- β^* **“betatron” amplitude function at collision point**
- $R(\varphi)$ **geometric reduction factor due to crossing angle**

$$\mathcal{L} = \frac{N_b^2 k_b f_{\text{rev}} \gamma}{4\pi \epsilon_n \beta^*} \mathcal{R}(\phi)$$

$$\frac{dR}{dt} = \mathcal{L} \sigma_p$$

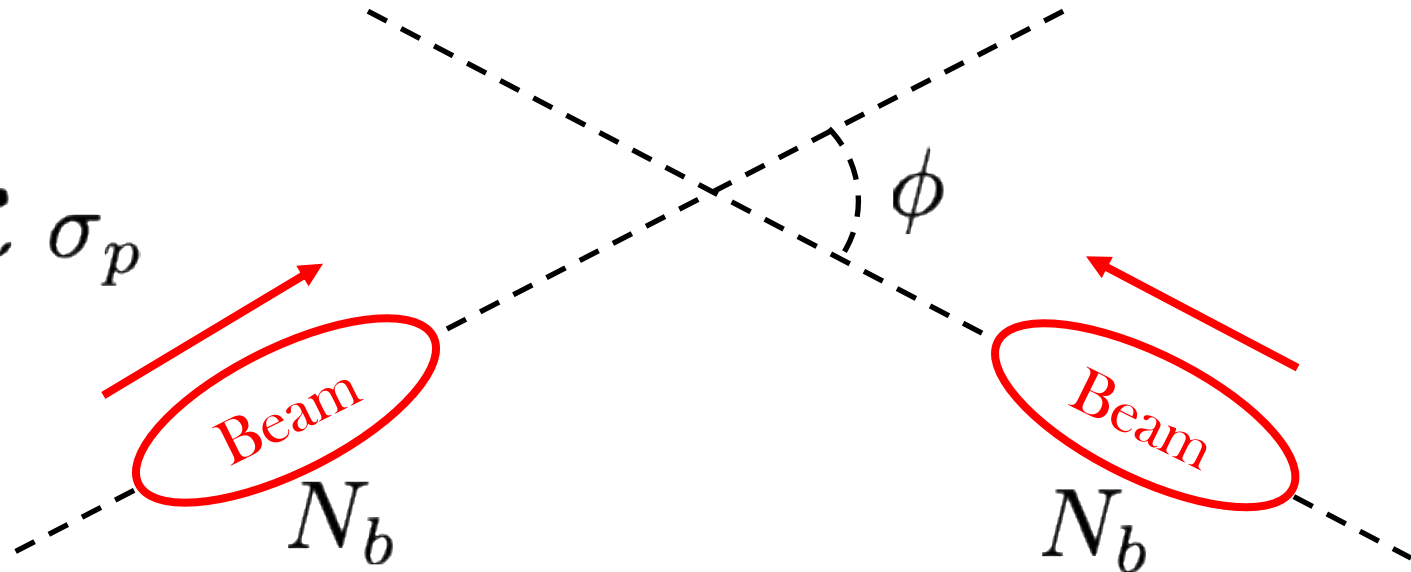

- Proportional to **square of bunch intensity**
- Proportional to **number of bunches** (or total intensity/beam)
- Inversely proportional to **square of beam size**

- **Brightness** $\mathcal{B} = \frac{N_b}{\epsilon_n}$ reach $\mathcal{L} = \frac{N_b^2 k_b f_{rev} \gamma}{4\pi \epsilon_n \beta^*} \mathcal{R}(\phi)$

depends on **injector chain** while **brightness preservation** depends on collider

- Logarithmic increase of **peak luminosity** over time
- Recipe for **luminosity increase** --> **Beam dynamics and HW implications**

Colliders and related accelerators, IPAC'26 Student Tutorial, 16 May 2026

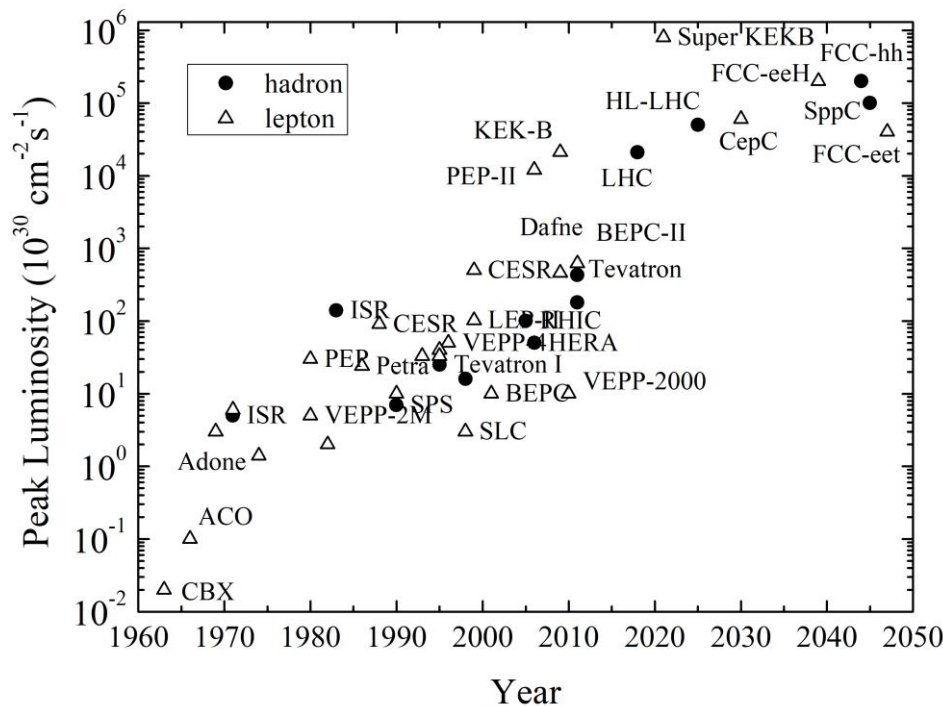

$$\mathcal{L} = \frac{N_b^2 k_b f_{rev} \gamma}{4\pi \epsilon_n \beta^*} \mathcal{R}(\phi)$$

V. Shitsev, F. Zimmermann, 2021

- Logarithmic increase of **peak luminosity** over time
- Recipe for **luminosity increase** \dashrightarrow **Beam dynamics and HW implications**
 - maximize intensities, minimize emittance \dashrightarrow **Brightness reach (injectors) and preservation (collider)**
 - minimize beam size \dashrightarrow **Optics and magnet technology**
 - compensate for geometric reduction factor \dashrightarrow **Crabbing, beam-beam**
 - maximize number of bunches (beam power) \dashrightarrow **Minimise bunch spacing**
 - improve machine efficiency i.e. maximize **integrated luminosity**

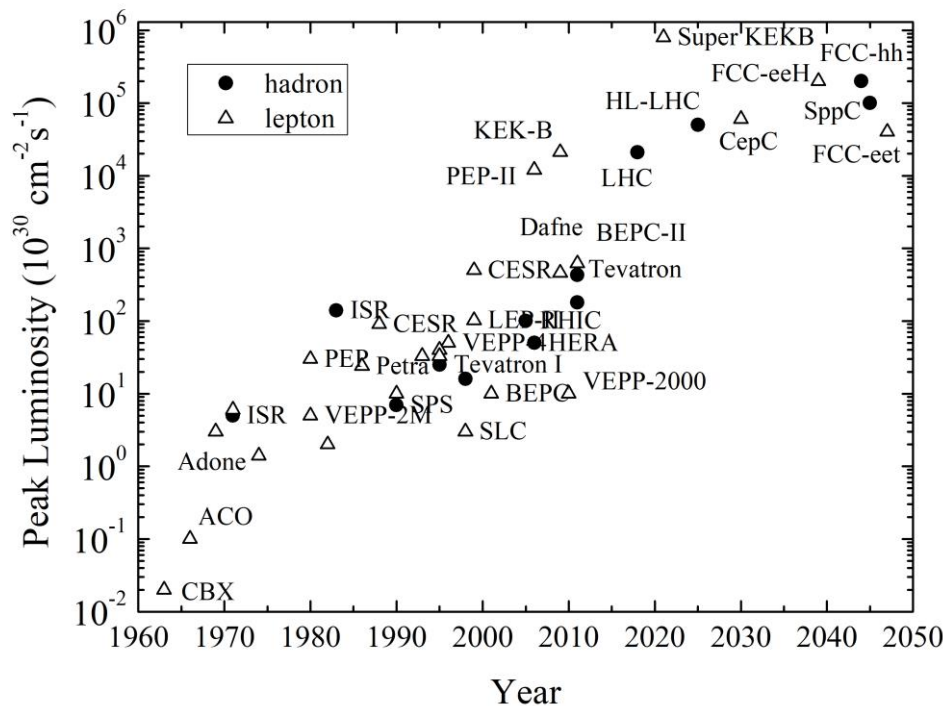

$$\mathcal{L} = \frac{N_b^2 k_b f_{rev} \gamma}{4\pi \epsilon_n \beta^*} \mathcal{R}(\phi)$$

Hadron Colliders

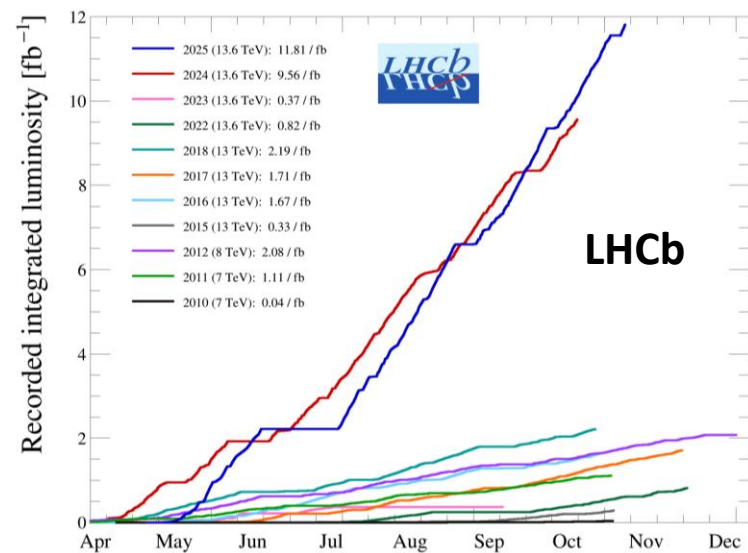
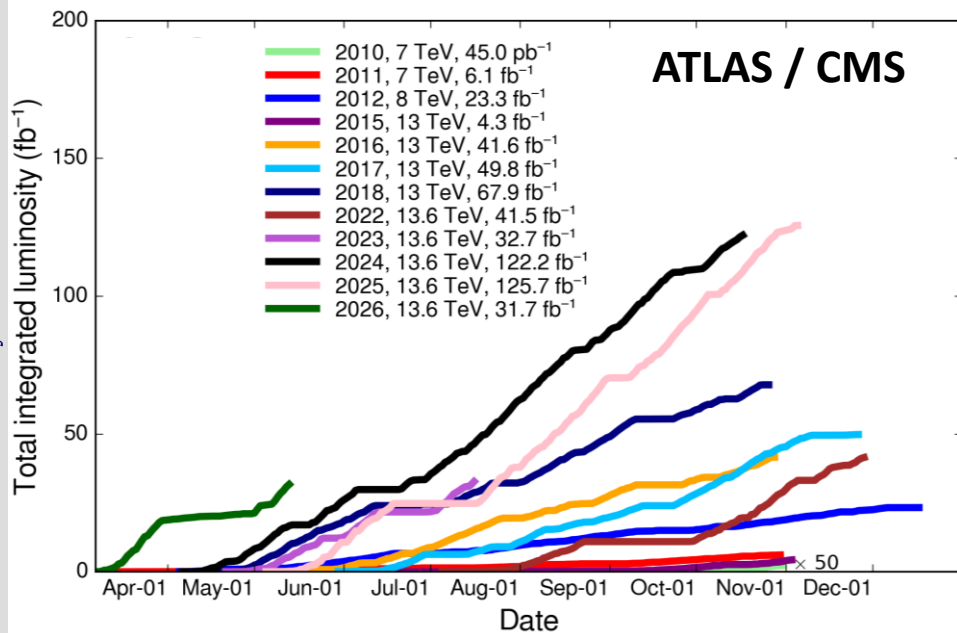

- LHC intensity increased from $1.1e11$ (design) to $1.8e11$ ppb, while β^* reduced down to 15cm (flat optics and luminosity leveling) more than doubling peak luminosity
- 2025 was the single most productive year in LHC history so far!
- Over 500 fb⁻¹ delivered to both ATLAS and CMS since 2010
- LHCb more than doubled their Run 1 + Run 2 + Run 3 data set
- ... despite limitations from e-cloud (heat load and cryo capacity), beam induced heating due to impedance (vacuum modules' RF fingers)
- Reached $1.8e11$ ppb by end of Run3 (2026) for physics conditions and HL-LHC intensities of $2.3e11$ ppb in machine studies

$$L = \frac{n_b \times N_1 \times N_2 \times g \times f_{rev}}{4p \times b^* \times e_n} \times F(f, b^*, e, S_s)$$

- 1) maximize bunch intensities → Injector complex Upgrade LIU
- 2) minimize the beam emittance → triplet aperture
- 3) minimize beam size (constant beam power); → 25ns
- 4) maximize number of bunches (beam power); → Crab Cavities
- 5) compensate for 'F'; → minimize number of unscheduled beam aborts
- 6) Improve machine 'Efficiency'

- Connection of PSB to **Linac4** and acceleration to **2 GeV** in PSB
- PS & SPS RF upgrades + e-cloud & impedance reduction, new SPS optics, new dumps & stoppers,...



PSB new power supply building

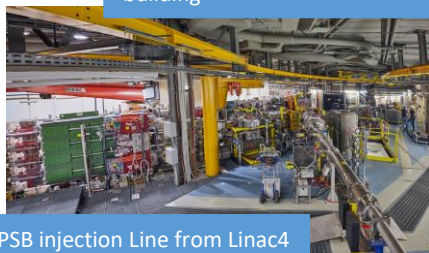

PSB injection Line from Linac4

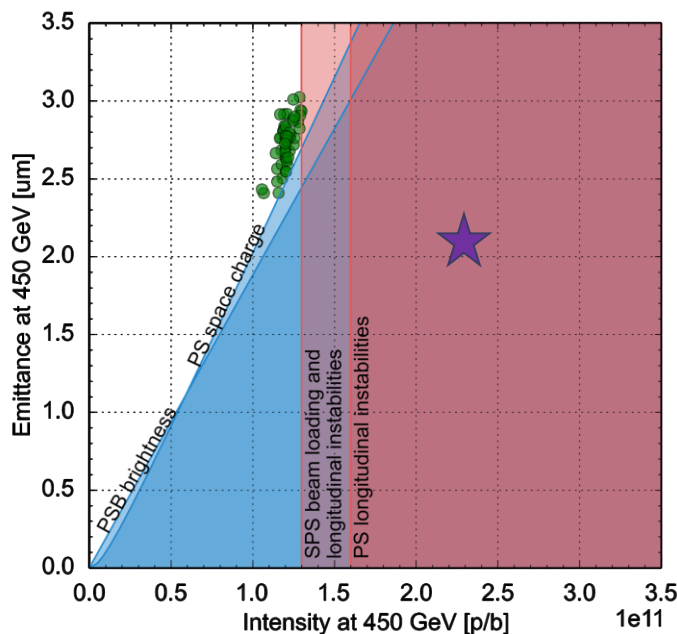

New SPS beam dump



PS longitudinal damper



New SPS RF amplifier towers

- LIU beam intensity reached during scrubbing run (e-cloud)
- Established ~LIU parameters, repeatedly, with 25 ns standard @ 4 x 72 bunches and with BCMS @ 5 x 48 bunches

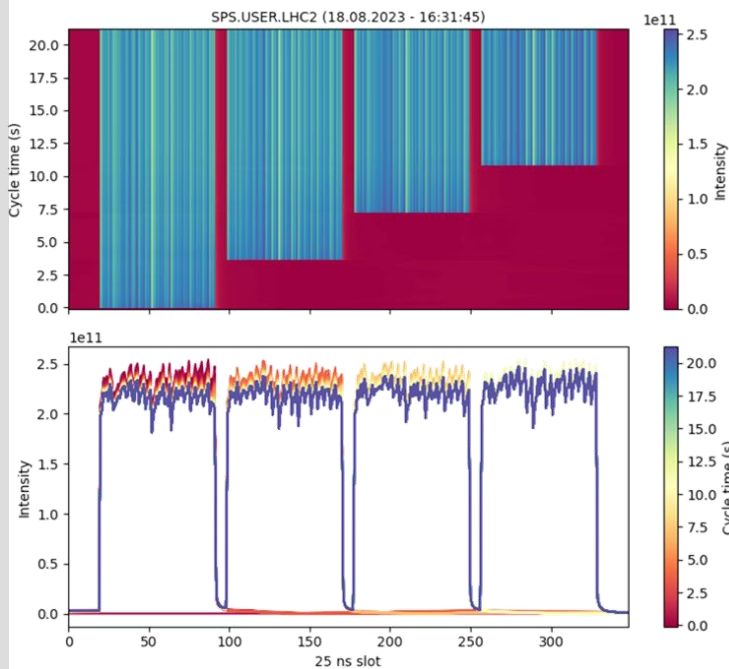

$I_{FB} = 2.3e11$; $\epsilon_{ps_{avg}} = 1.9 \mu m$

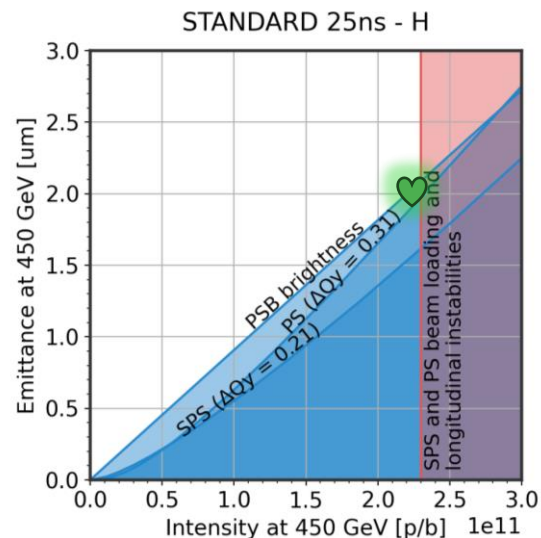
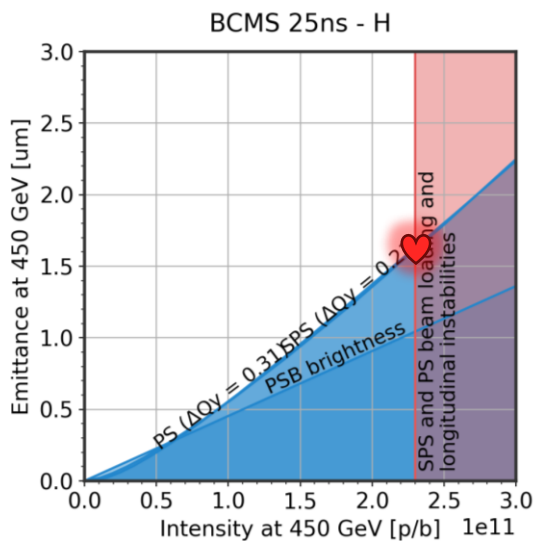

$I_{FB} = 2.3e11$; $\epsilon_{ps_{avg}} = 1.5 \mu m$

H. Bartosik, K. Li, G. Rumolo et al.

LHC beam quality optimization along injector chain for increasing brightness and reducing losses

- PSB**

Introduced **transverse scraping** at low energy to maintain **Gaussian** profiles

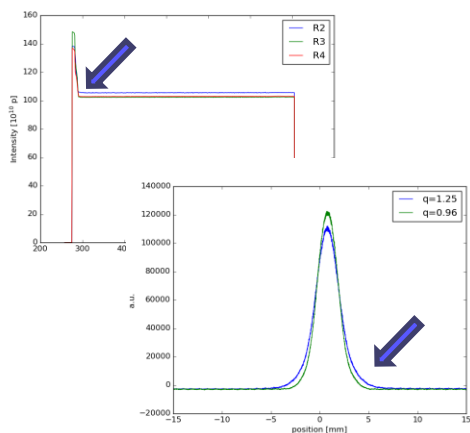

- PS**

Working point optimization, around transition crossing, to maintain **Gaussian** profiles along the year

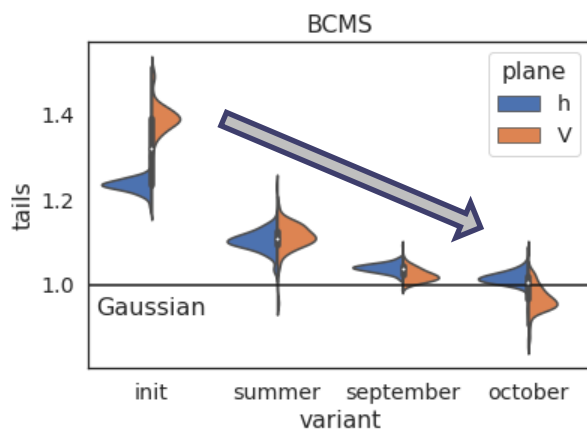

- SPS**

Working point optimization and **Laslett correction** to push brightness → ~LIU BCMS target

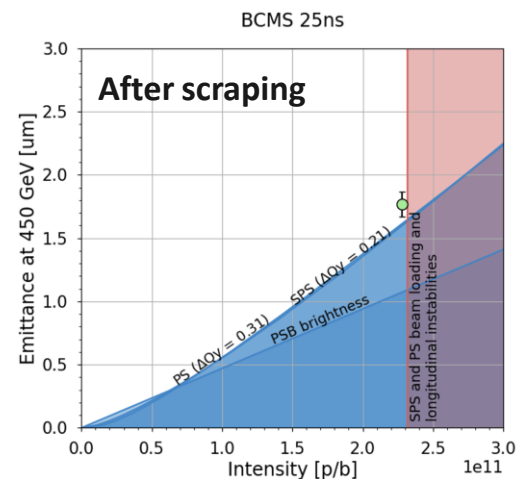

Parameter	Design	Achieved
# of bunches with 2.3×10^{11} ppb		
SPS→LHC injection (Standard)	4×72	4×72
LHC injection energy (Standard)	2760	1152
SPS→LHC injection (BCMS)	5×48	2×48
LHC injection energy (BCMS)	2748	972
SPS→LHC injection (8b4e)	4×56	2×56
LHC injection energy (8b4e)	1972	560
Emittance [μm] (at 2.3×10^{11} ppb)		
SPS (Standard)	2.1	2.1
LHC injection (Standard)	2.1	2.2
SPS (BCMS)	1.7	1.7
LHC injection (BCMS)	1.7	2.0
SPS (8b4e)	1.7	1.7
LHC injection & Flattop (8b4e)	1.7	1.6
β functions [m] (achieved in operation / MD 10^{10} p)		
Peak β in the arcs	600	600/1040
Minimum β^* at the IP	0.15	0.18/0.1
Tune shift (for 36 bunches each 1.8×10^{11} p)		
Beam-beam head-on (2 IPs)	0.020	0.02
Beam-beam long-range (1 IP)	0.004	0.009

HL-LHC new baseline

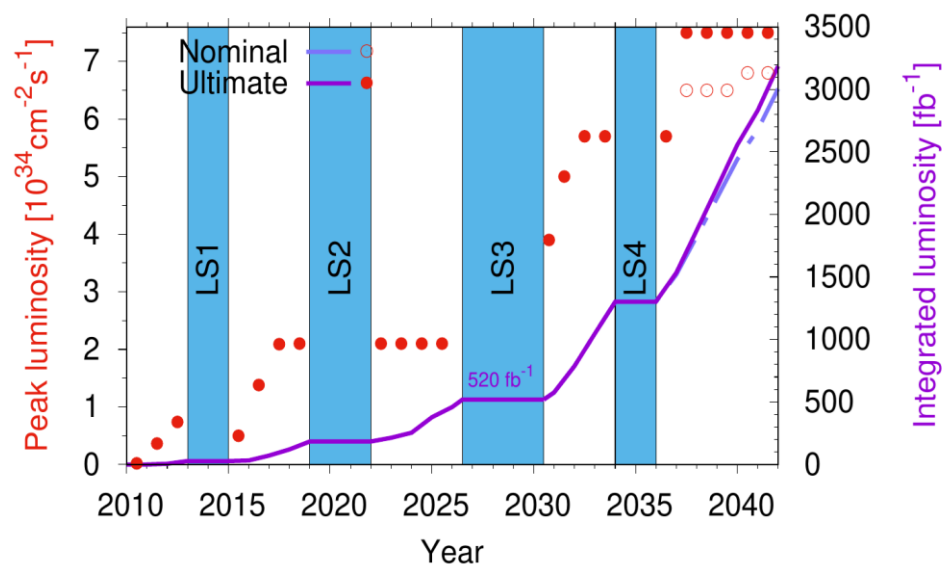

Round Optics baseline

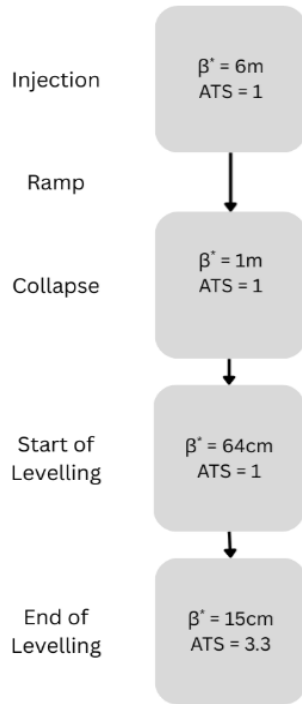

Flat optics potential benefits

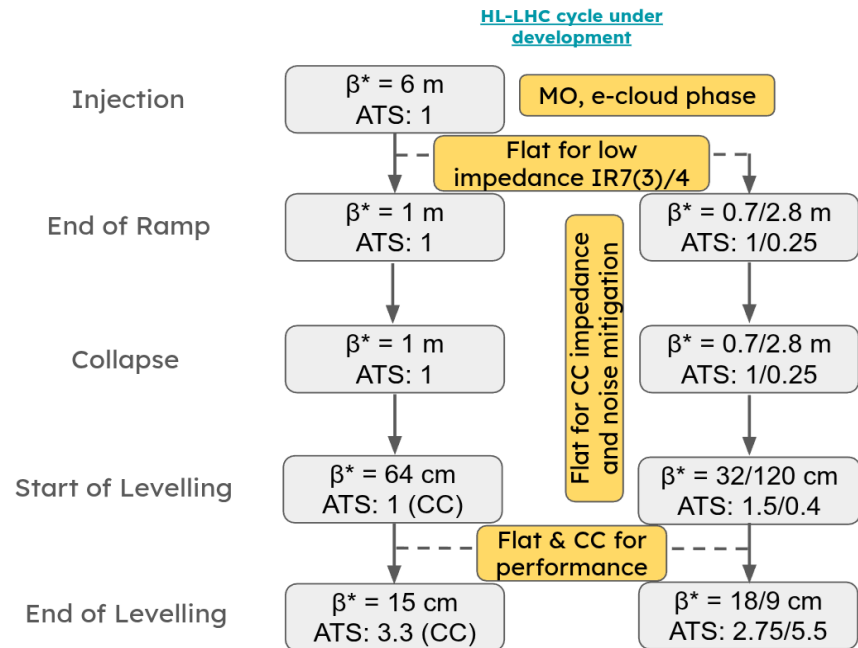

New IR7 after global phase optimization

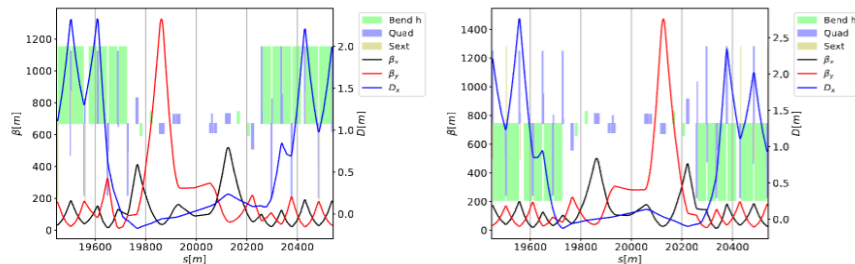

Critical Phases @15 cm with new IR7

CC-TCP	B1		B2		Purpose
	Left	Right	Left	Right	
CC1H	13.30	11.86	-29.10	-27.74	Machine prot.
CC5V	24.18	22.72	22.10	23.46	Machine prot.
MKD-TCT	MKD.A	MKD.0	MKD.A	MKD.0	
TCTH1	9.98	15.93	-20.55	-16.43	β^* reach in Pt1
TCTH5	-30.16	-24.20	-32.34	-28.21	β^* reach in Pt5
TCTH8	20.28	26.24	41.41	45.54	β^* reach in Pt8
TCP-TCT	H	V	H	V	
TCT1	-81.34	52.66	-40.35	80.04	Background in Pt1
TCT5	58.52	-88.68	-52.14	-88.01	Background in Pt5
TCT8	-71.04	30.41	21.61	30.53	Background in Pt8

- Design, engineering, construction, test and installation the Insertion Region (IR) magnets of IR1 and IR5 for the HL-LHC upgrade.
 - Q1/Q3 cryoassemblies: from AUP (US)
 - Q2: from CERN
 - MCBXF nested corrector magnets: from CIEMAT (Spain)
 - HO corrector magnets: from INFN-LASA (Italy)
 - D1 cold masses: from KEK (Japan)
 - D2 magnets: from INFN-Ge (Italy)
 - D2 corrector magnets: from IHEP (China)
 - Interconnection modules DCM/DQM: from CERN

- Refurbishment LHC Q4, Q5 and Q10 during LS3

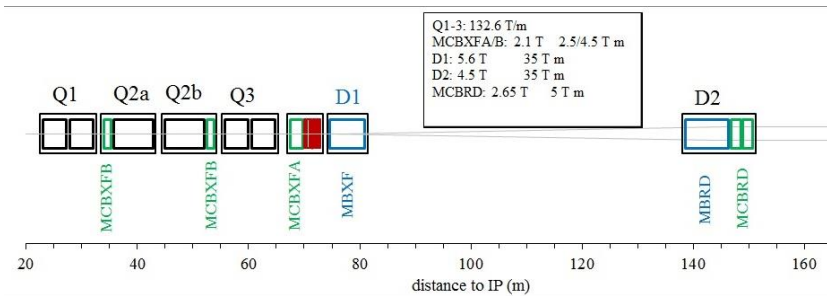

Triplet [G. Ambrosio, P. Ferracin et al.]
D1 [T. Nakamoto, et al.]
MCBXF [F. Toral, et al.]
D2 [P. Fabbriatore, S. Farinon, et al.] D2 correctors [G. Kirby, O. Xu, et al.]

- E/M interaction due to crossing of two beams in collision point (**head-on**) but also while separated in common beam pipe (**long-range**) induces

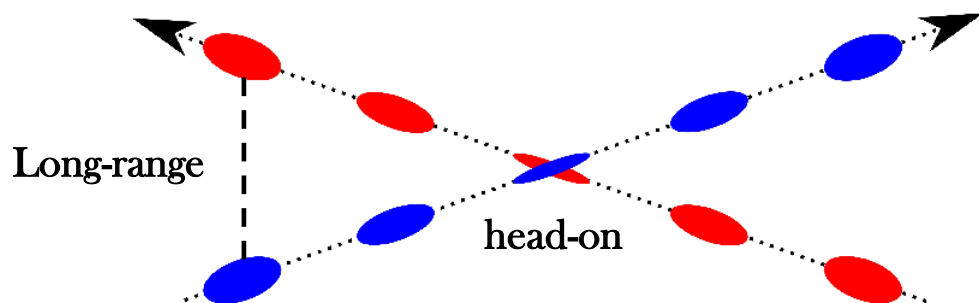

- E/M interaction due to crossing of two beams in collision point (**head-on**) but also while separated in common beam pipe (**long-range**) induces
 - Coherent instabilities
 - Incoherent effects, i.e. beam losses and slow emittance growth

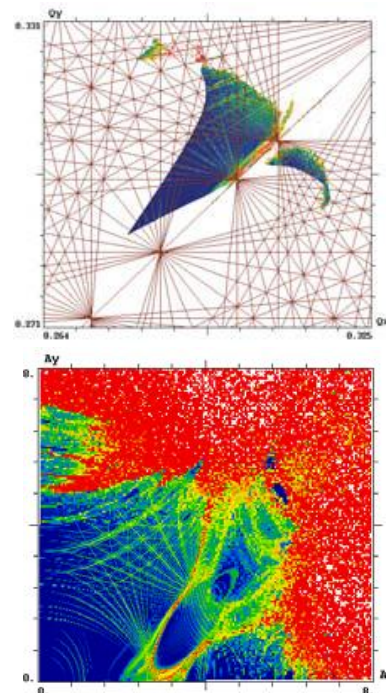
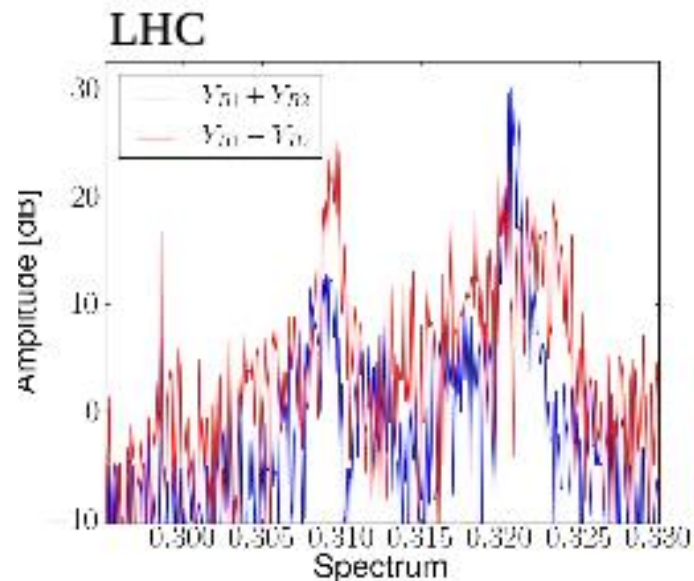
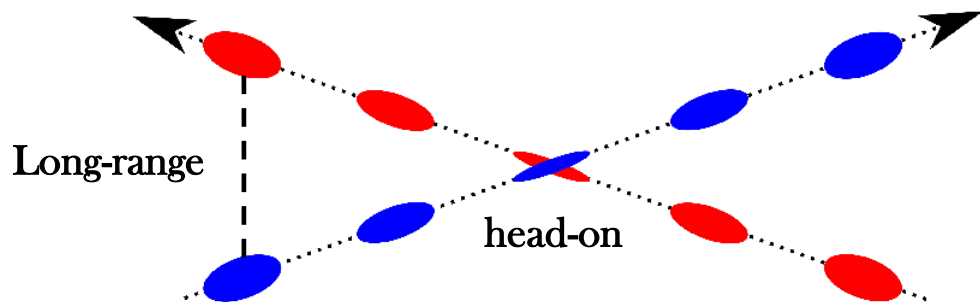

- E/M interaction due to crossing of two beams in collision point (**head-on**) but also while separated in common beam pipe (**long-range**) induces
 - Coherent instabilities
 - Incoherent effects, i.e. beam losses and slow emittance growth
- **Mitigation** methods
 - non-linear magnets, e-lenses, **DC wires** and crab cavities

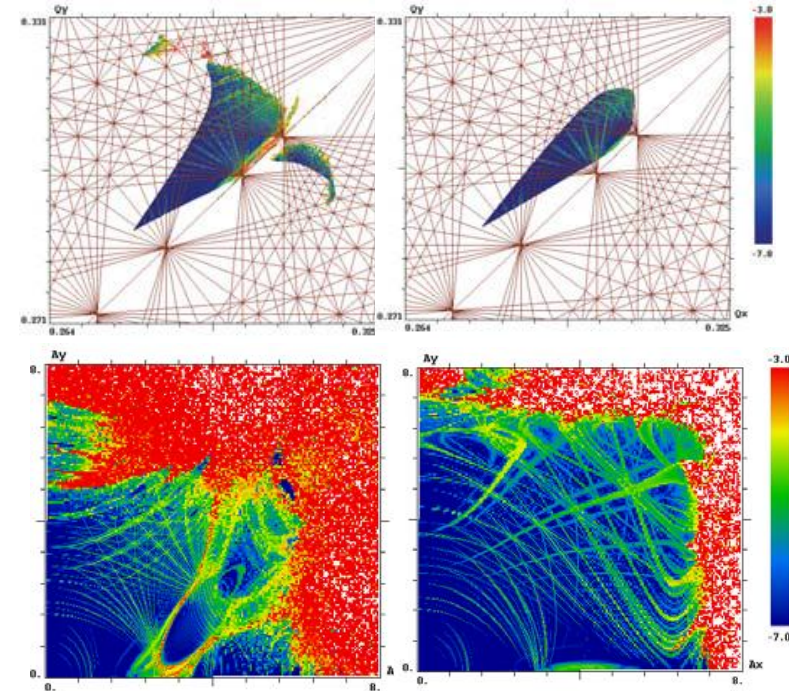
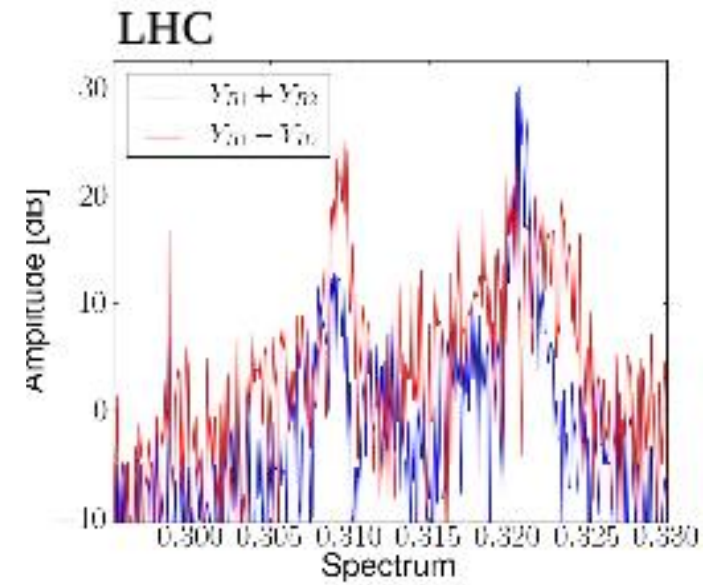
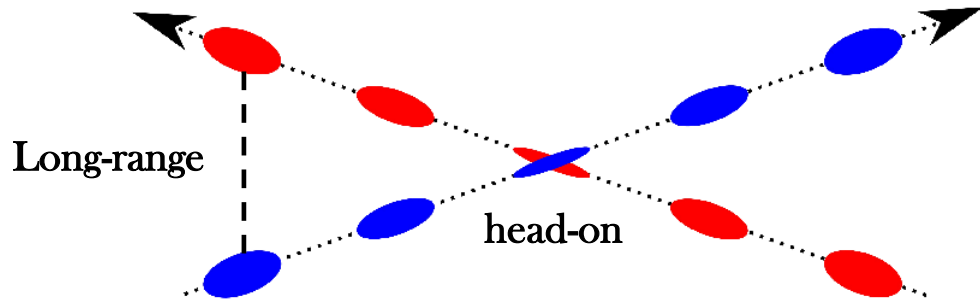

Tilt beams longitudinally for increasing overlap with **crab cavities**



CC tests in the SPS demonstrated crabbing with protons – for the first time !

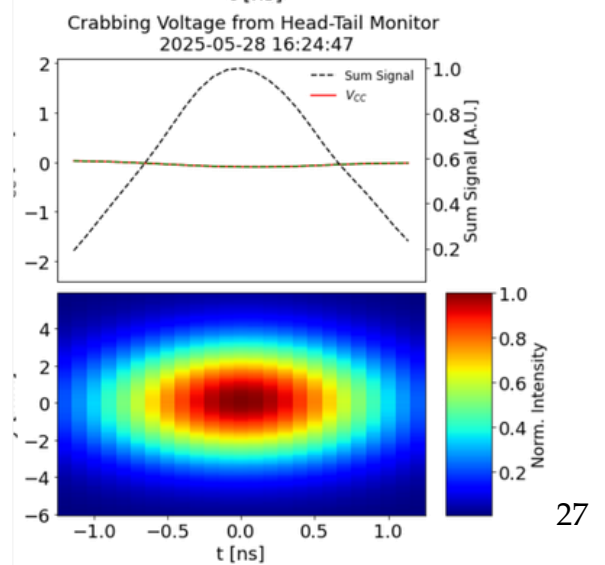
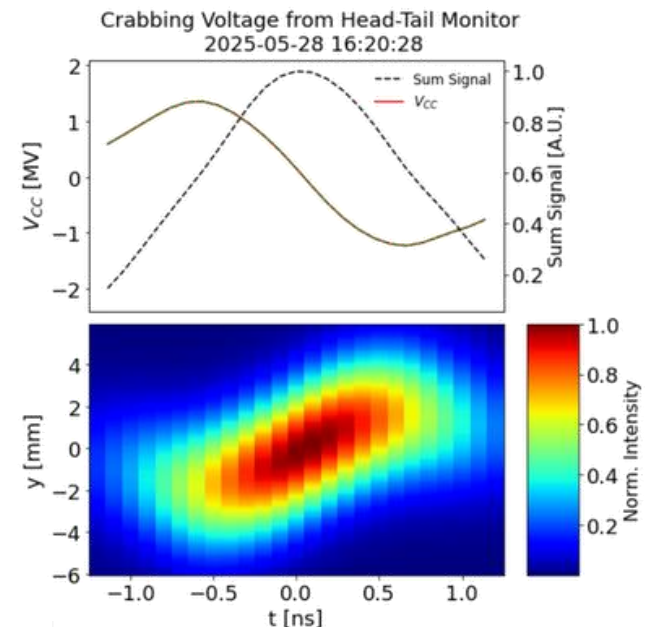
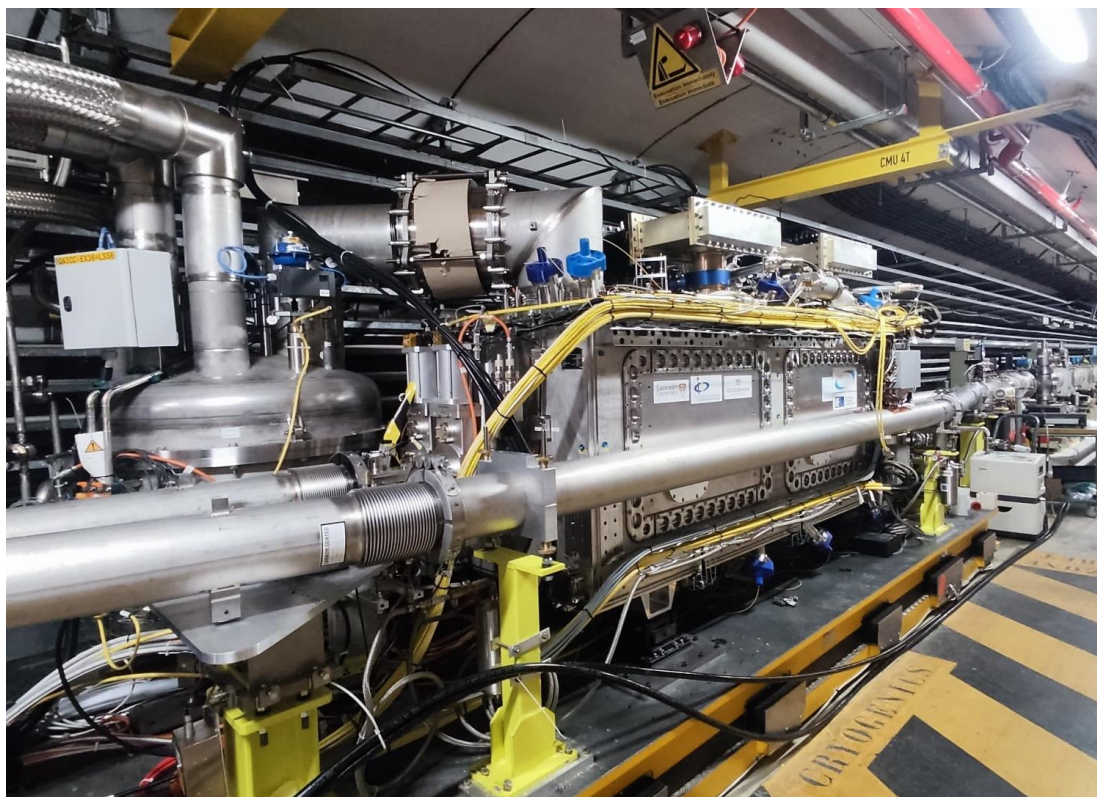

Generation of charged particles inside the vacuum chamber
(primary, or seed, electrons)



- Acceleration of primary electrons in the beam field
- Secondary electron production when hitting the wall
 - Avalanche electron multiplication if SEY > 1

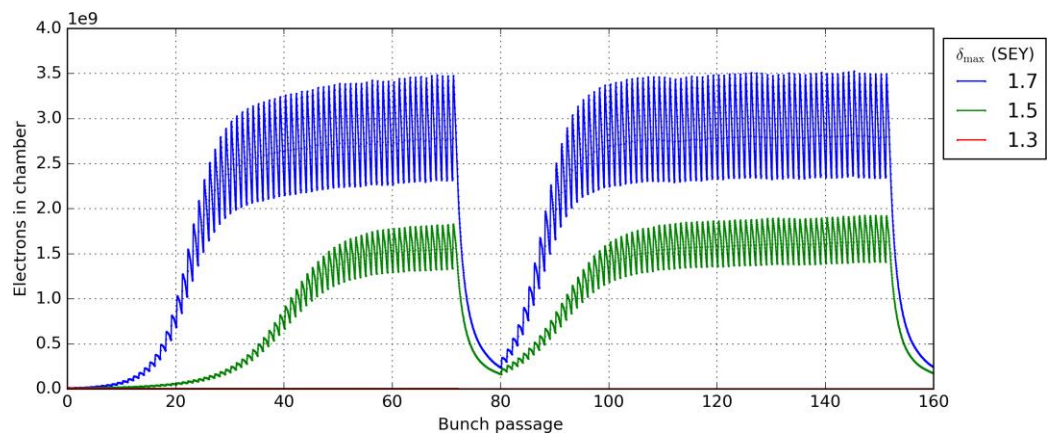
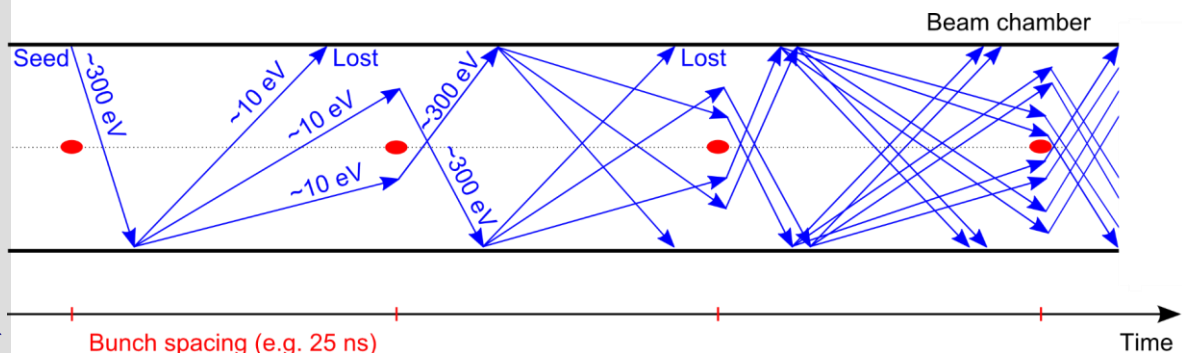

Generation of charged particles inside the vacuum chamber (primary, or seed, electrons)



- Acceleration of primary electrons in the beam field
- Secondary electron production when hitting the wall
 - Avalanche electron multiplication if $SEY > 1$

- Coherent instabilities
- Incoherent effects, i.e. beam losses and slow emittance growth

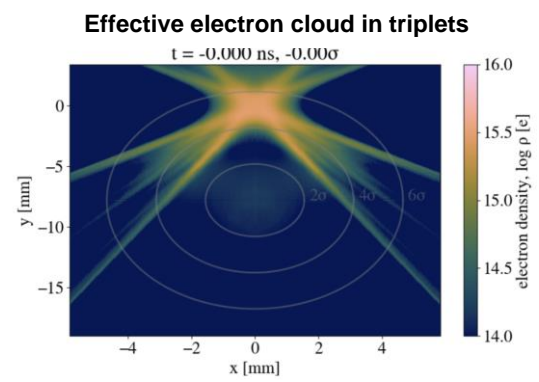
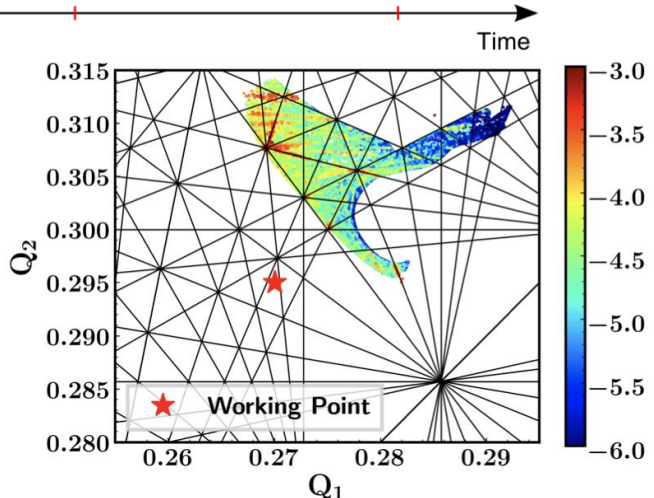
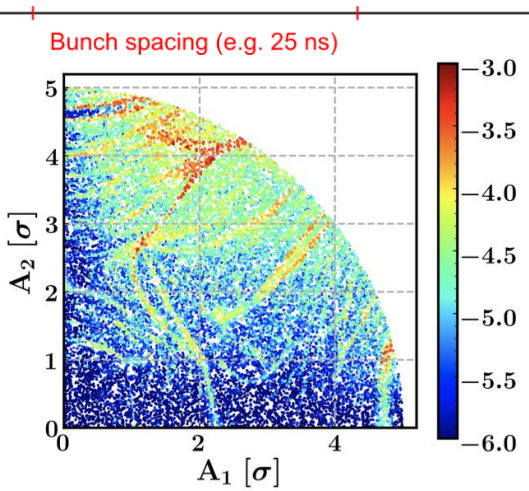
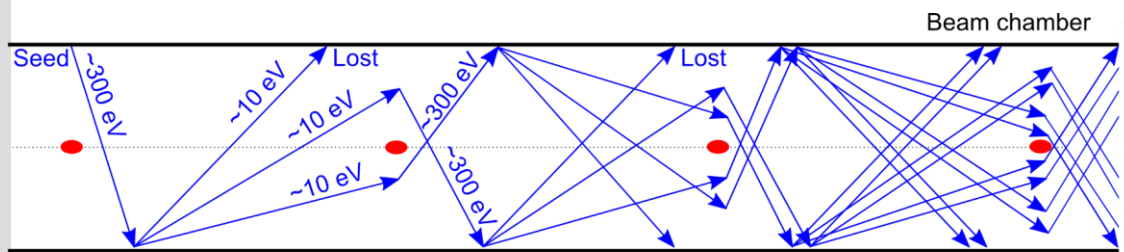

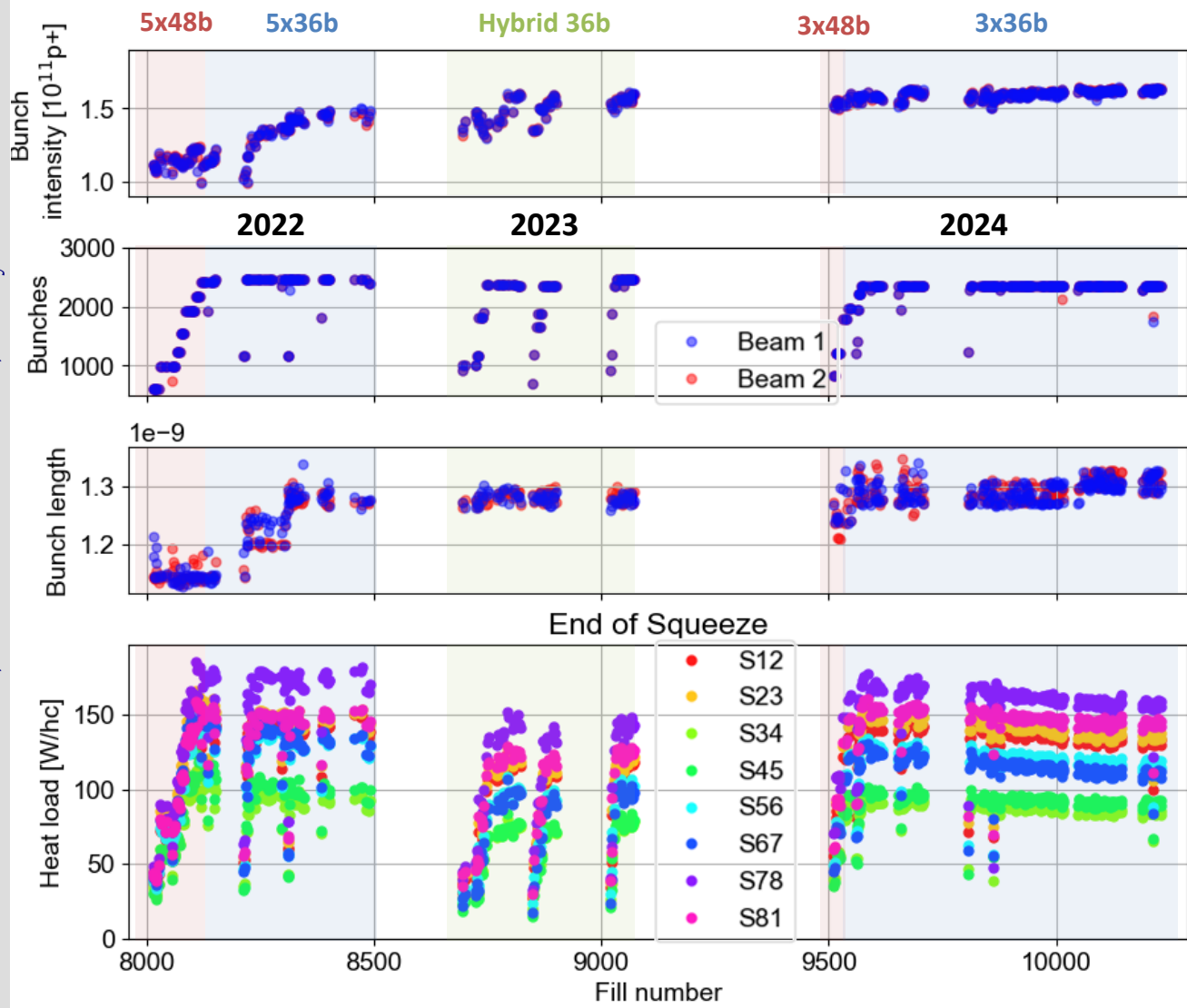

- **Coherent instabilities**
- **Incoherent effects, i.e. beam losses and slow emittance growth**
- **Pressure rise, heat load**
- **Mitigation methods**
 - **Non-linear magnets, bunch spacing increase/variation, coatings, scrubbing**

Issue

Non-uniform heat load in LHC arcs, degradation observed following each Long Shutdown

Origin

Presence of **CuO oxide** and **reduced carbon concentration** at beam screen surface

- reduced conditioning efficiency
- **Secondary Electron Yield > e-cloud threshold**

Mitigation strategy

Deposit a **thin amorphous carbon layer** on the beam screens of **120 selected arc half-cells**

- recover **conditioning efficiency**
- ensure **surface robustness** against ventings (LS)

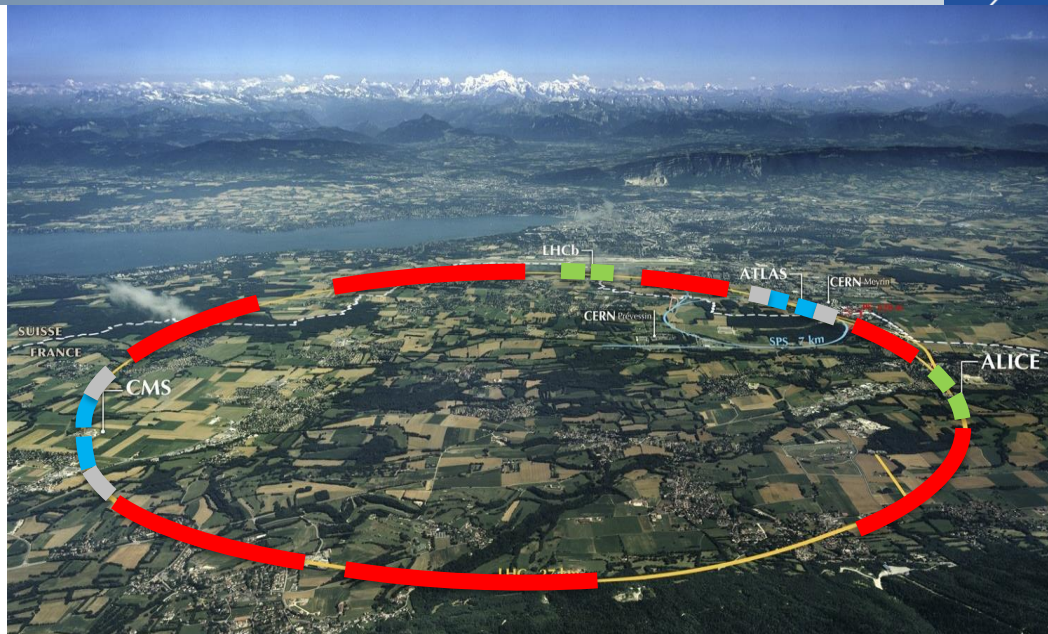

In. Triplets
IP2/8
 In-situ
 190 m total

In. Triplets
IP1/5
 Ex-situ
 320 m total

Matching sections
 Ex-situ, in magnet
 20 m total

Arcs
 In-situ
 ≈ 12 km
 total **BST**

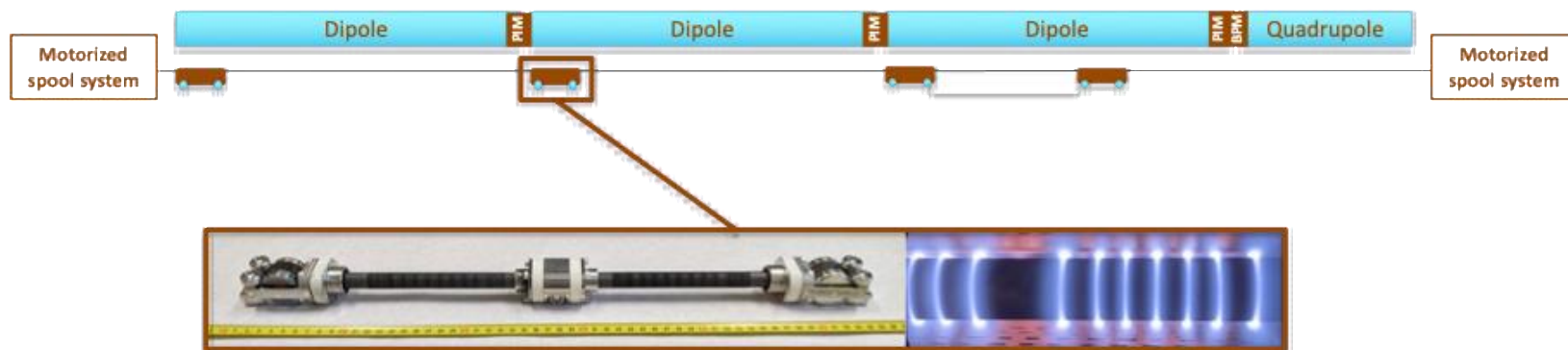

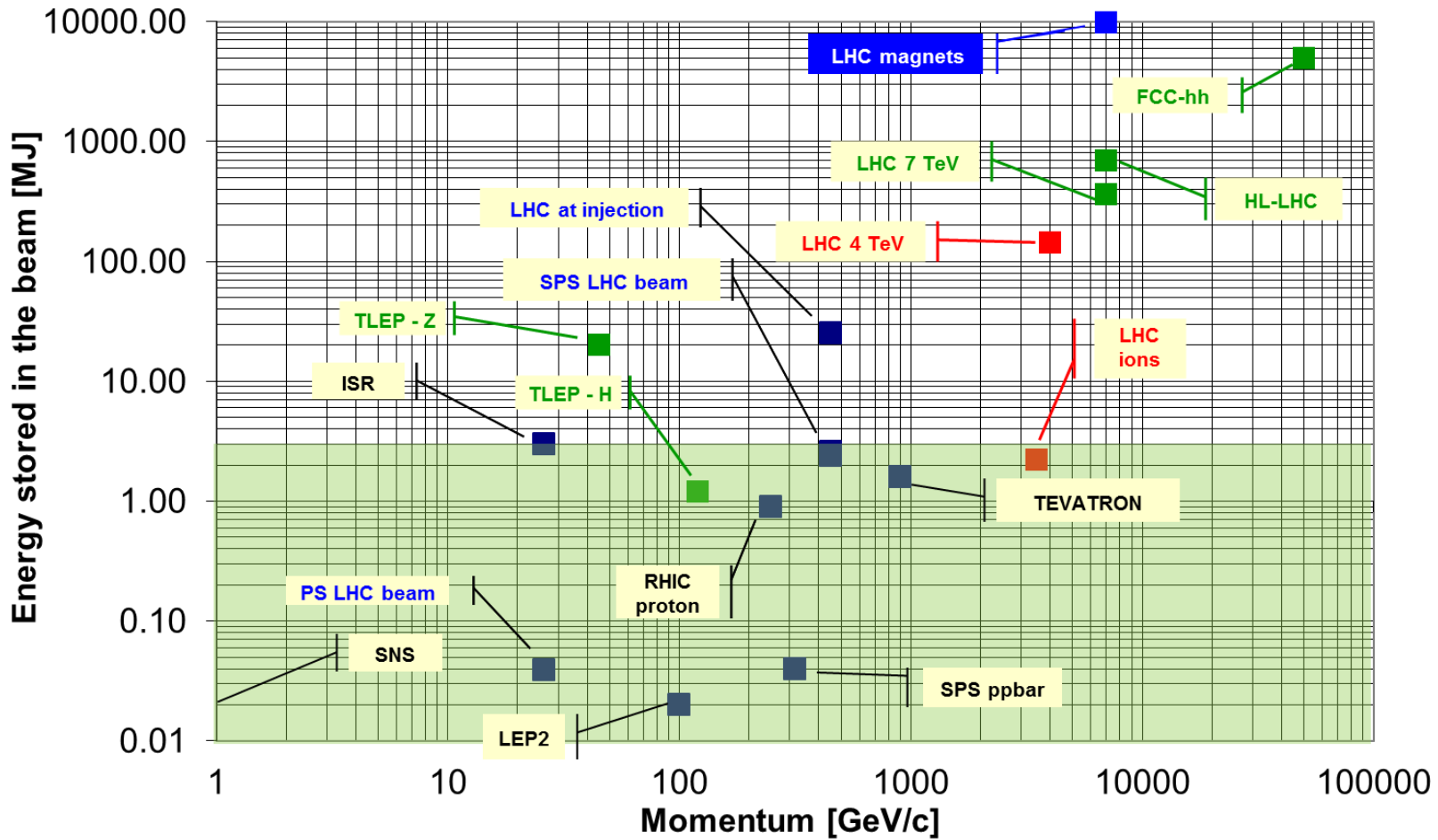

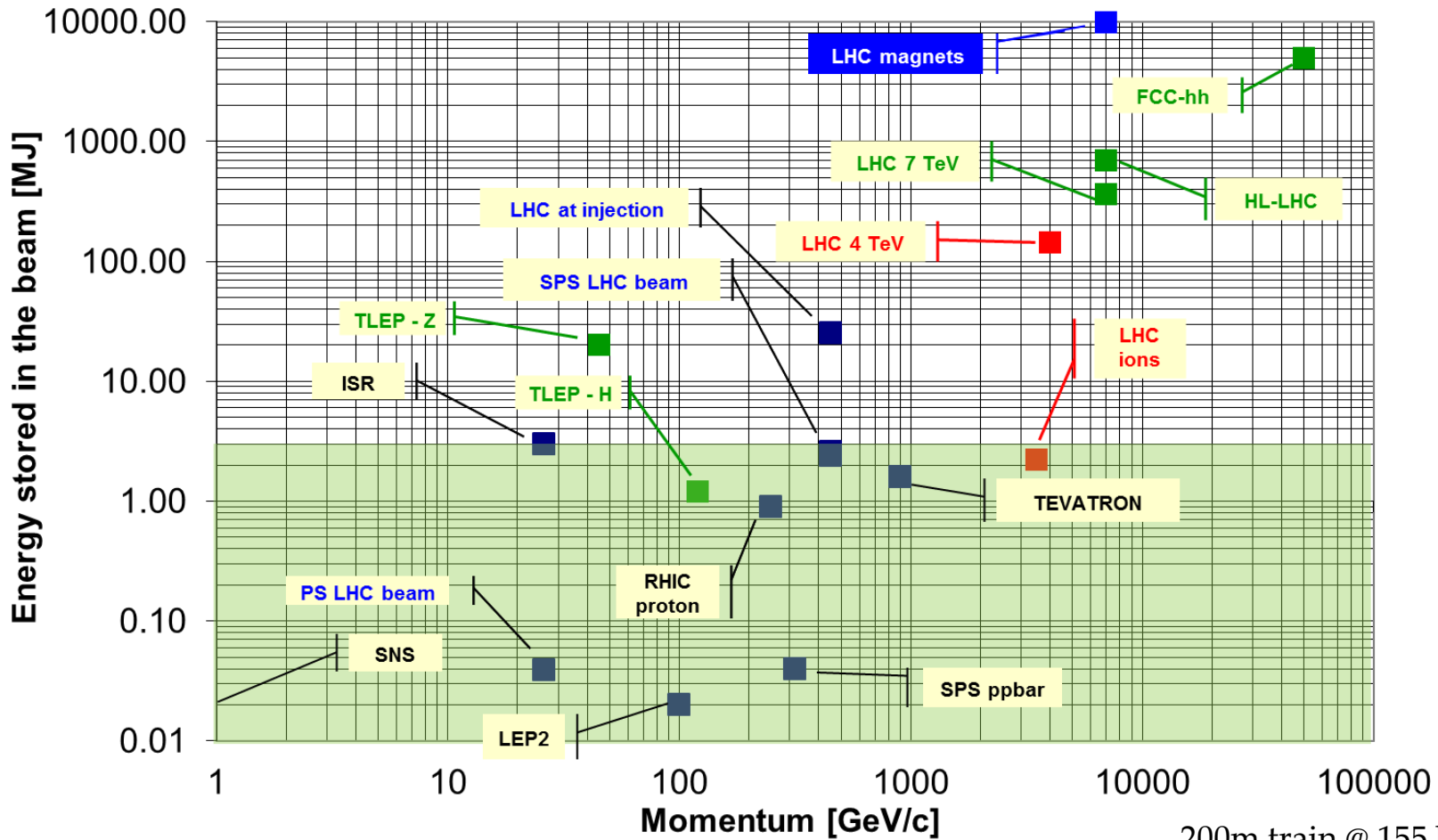

90kg of TNT



8L of gasoline



15kg of chocolate



200m train @ 155 km/h



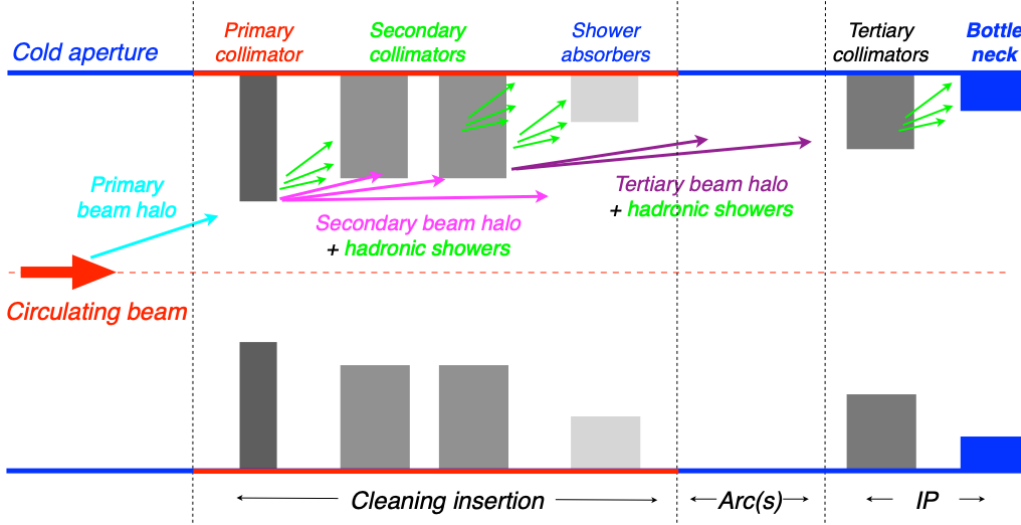

Multi-stage collimator system

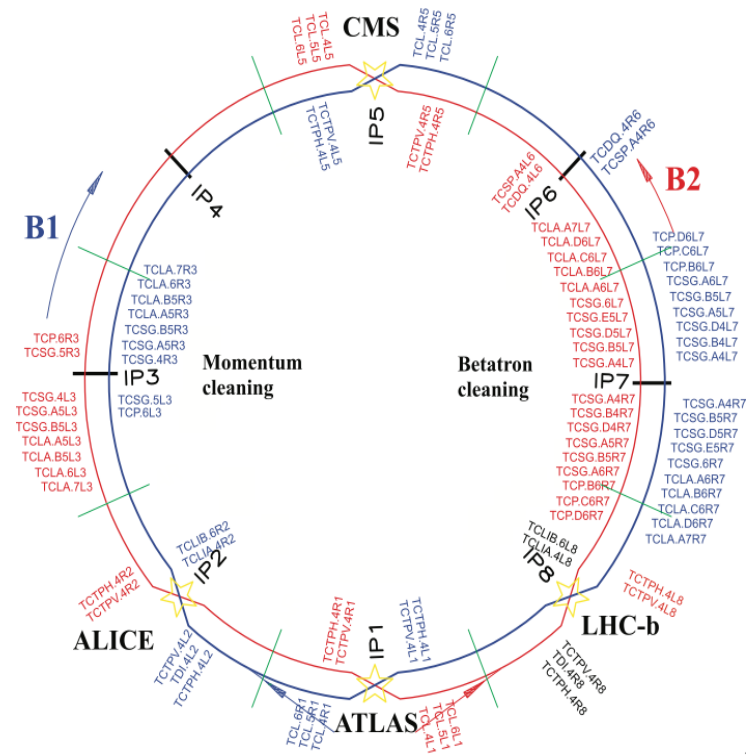

Total of 118 two-sided collimators

S. Redaelli, CAS2024

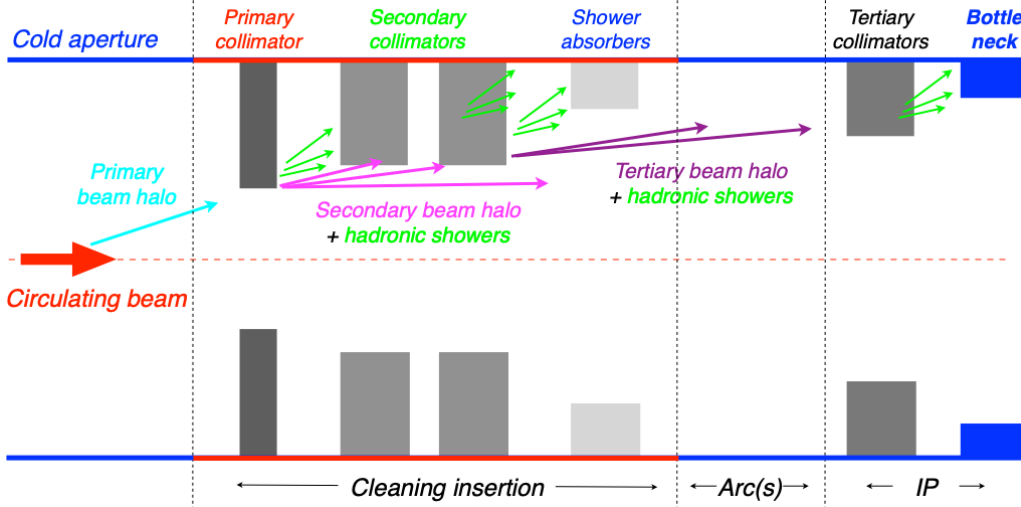

Multi-stage collimator system

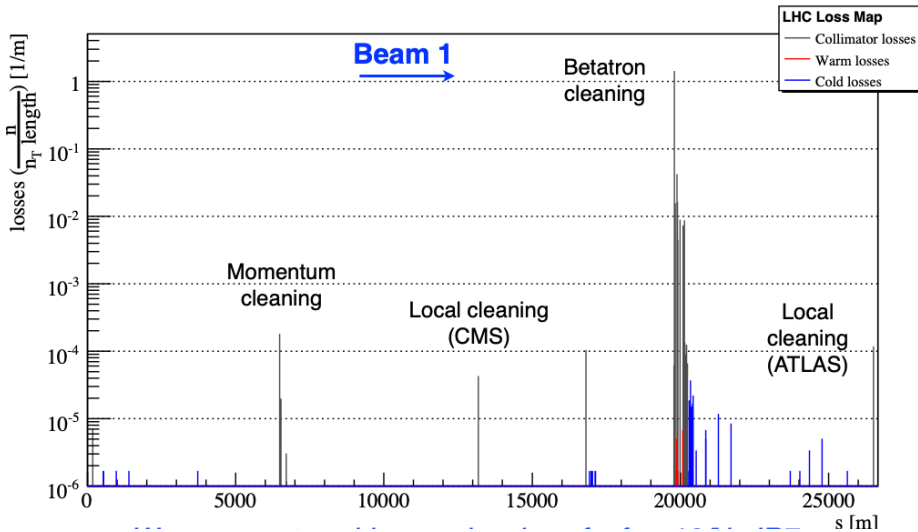

Loss maps achieving a few 10^{-5} efficiency

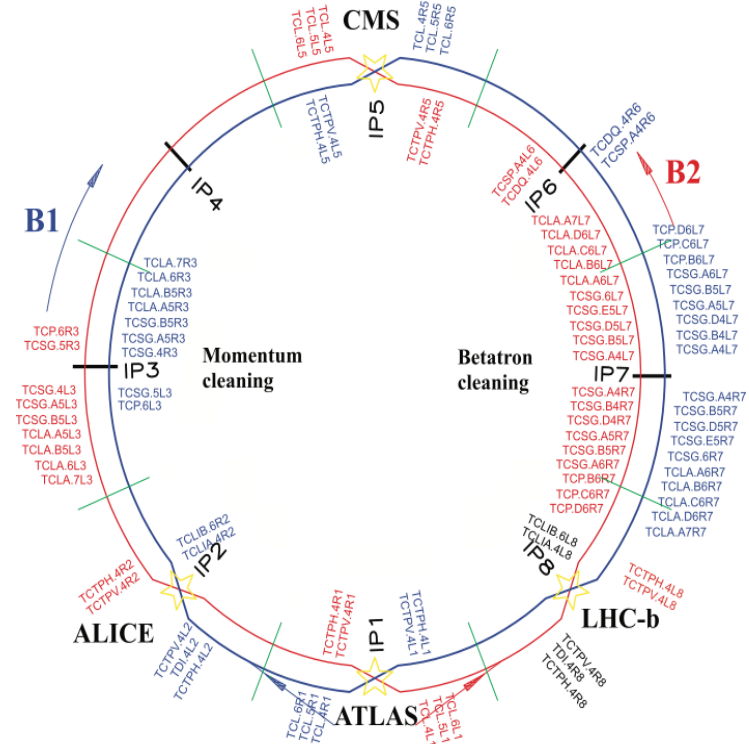

Total of 118 two-sided collimators

S. Redaelli, CAS2024

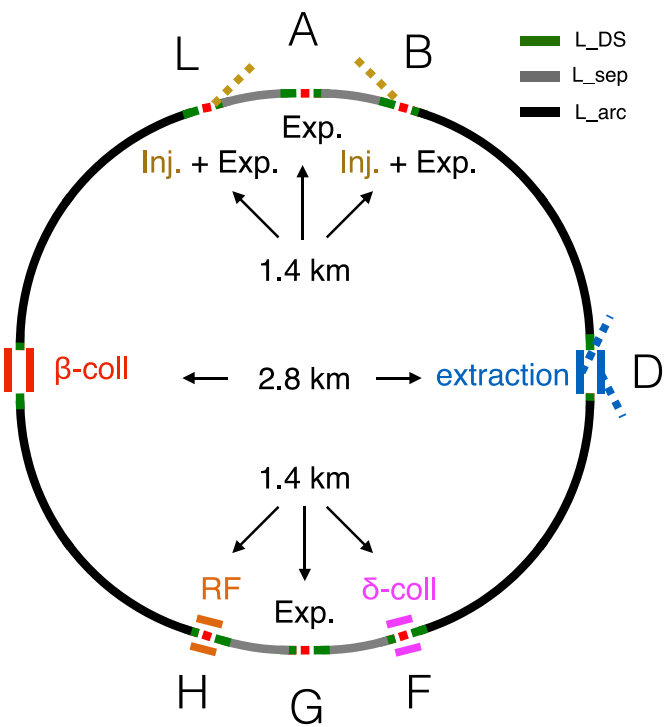

Circumference: 97.75 km

Main geometrical differences:

- Circumference length
- Straight section length
- Arc length
- Symmetry of experimental insertions
- Transverse position of interaction points
- Functional organisation of straight sections

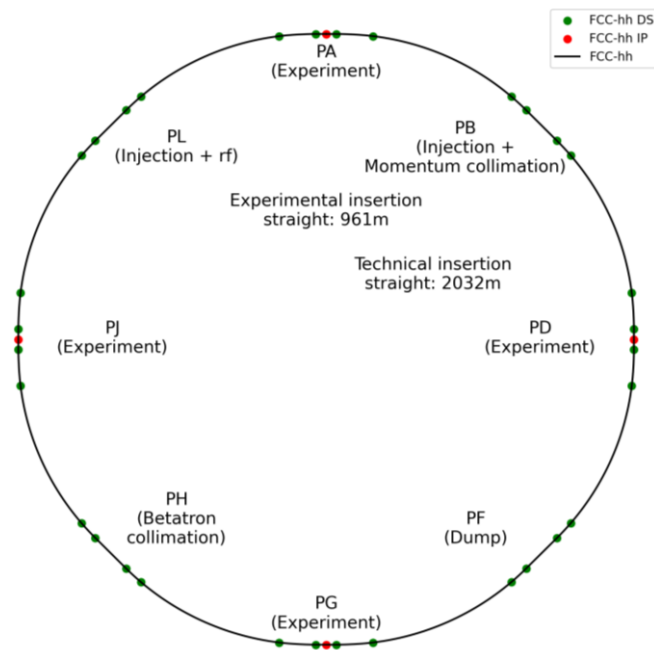

Circumference: 90.66 km

Parameter	Value
CoM energy [TeV]	84.6 – 120.8
Dipole field [T]	14 (Nb ₃ Sn/HTS) - 20 (HTS)
Dipole length [m]	14.187
Number of dipoles	4464
Circumference [km]	90.657

- **Maximized dipole filling factor to maximize collision energy**

M. Giovannozzi, et al.

Parameter	CDR cell 12-dipole	12-dipole	16-dipole
Number of dipoles	4668	4288	4464
Cell length [m]	213.030	213.030	275.792
Circumference [km]	97.75	90.657	90.657
CoM energy @14 T [TeV]	88.48	81.28	84.61

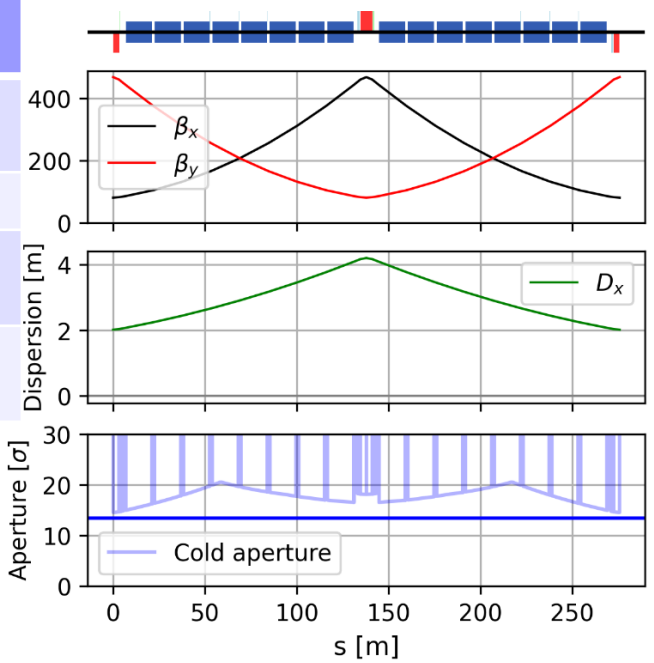

~275m

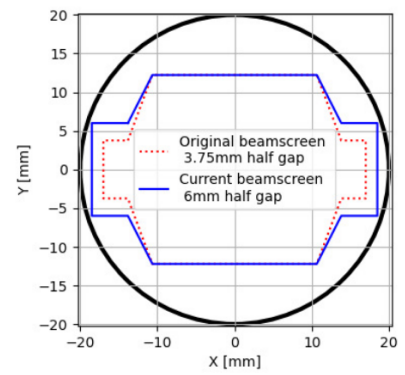

Short Straight Section

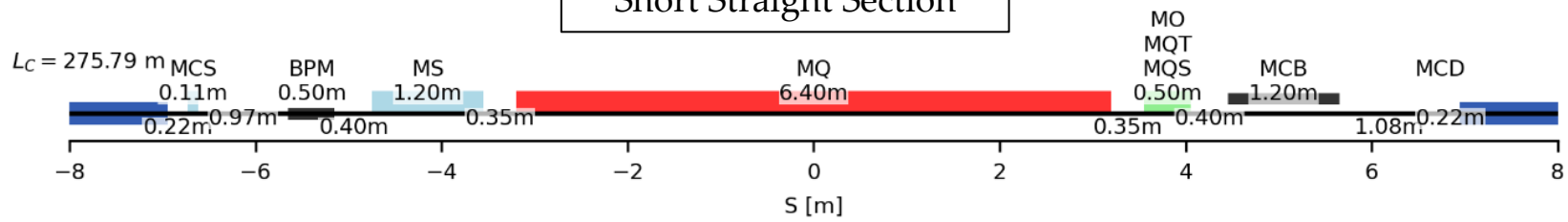

M. Giovannozzi, et al.

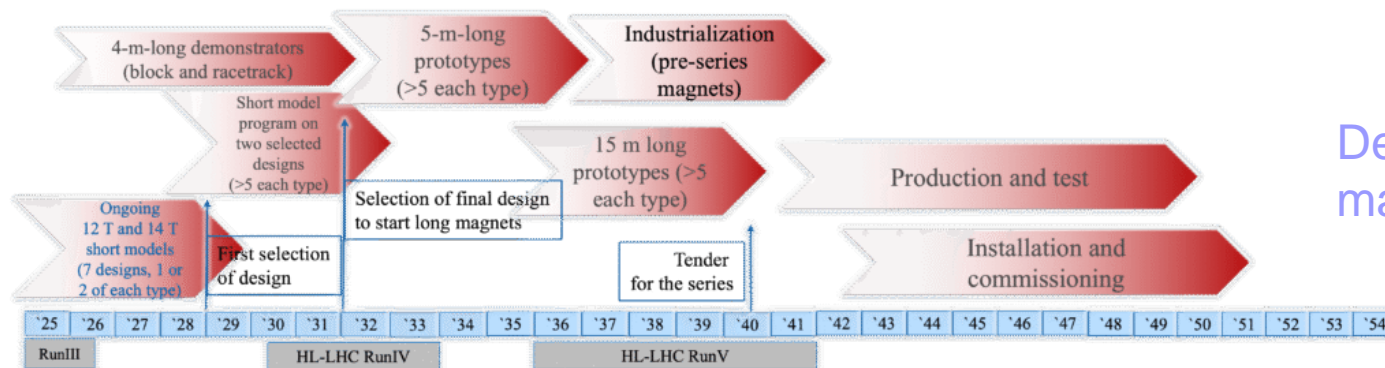

Development of Nb₃Sn magnets

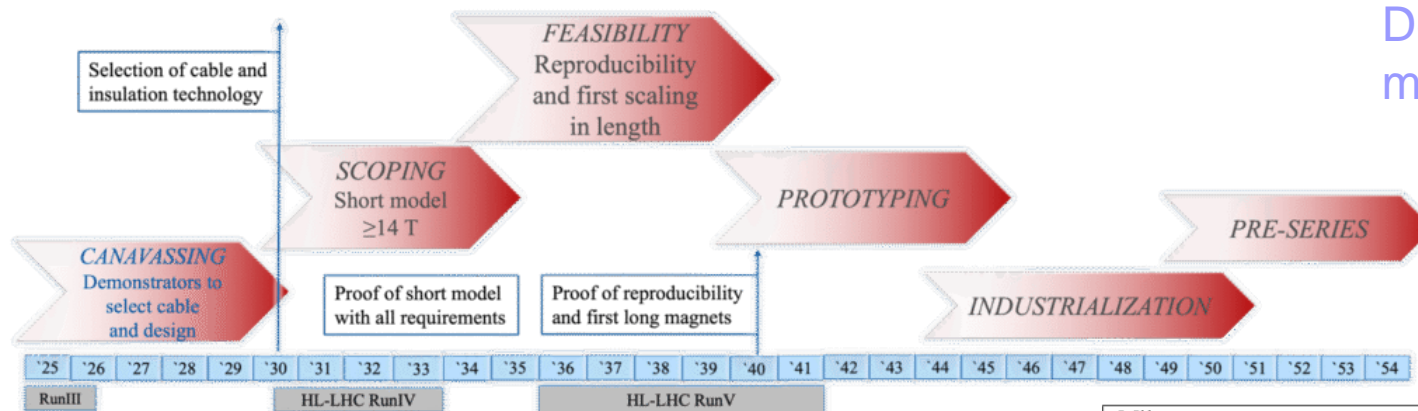

Development of HTS magnets

Full compatibility of the HFM activities with the FCC-hh schedule.

M. Giovannozzi, E. Todesco, et al.

Milestone	FCC-hh
Conceptual Design Study	2014 – 2018
Definition of the placement scenario	2022
Feasibility Report ready	2025
Main technologies R&D completion	2054
Technical Design Report ready	2054
Latest Project Approval	2054
Environmental evaluation & project authorisation processes	2054 – 2058
Industrialization & magnet production	2054 – 2069
Civil engineering - collider	2060 ^a - 2068
FCC-ee dismantling	2063 – 2064
TI installation – collider	2065 – 2069
Accelerator installation – collider	2068 – 2072
HW commissioning – collider	2071 – 2073
Beam commissioning – collider	2073
Physics operation start	2074

^a The starting date corresponds to the start of the surface CE works.

e^+e^- Colliders

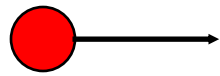

$$\mathbf{p} = m_0 \mathbf{v}$$

$$v \ll c$$

$$P_s = \frac{e^2}{6\pi\epsilon_0 m_0^2 c^3} \left(\frac{d\mathbf{p}}{dt} \right)^2$$

Larmor Power radiated by non-relativistic particles is very small

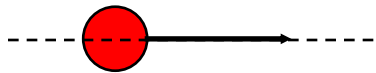

$$\mathbf{p} = \gamma m_0 \mathbf{v}$$

$$v \approx c$$

$$P_s = \frac{e^2}{6\pi\epsilon_0 m_0^2 c^3} \left(\frac{dp}{dt} \right)^2$$

Power radiated by relativistic particles in linear accelerators is negligible

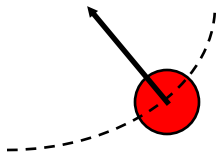

$$P_s = \frac{e^2 c}{6\pi\epsilon_0 (m_0 c^2)^4} \frac{E^4}{\rho^2}$$

Power radiated by relativistic particles in circular accelerators is very strong ([Liénard, 1898](#))

$$P_s = \frac{e^2 c}{6\pi\epsilon_0 (m_0 c^2)^4} \frac{E^4}{\rho^2}$$

$$\Delta E = \frac{e^2}{3\epsilon_0 (m_0 c^2)^4} \frac{E^4}{\rho}$$

- Inversely proportional to **4th power of rest mass** (e- mass $\sim 2e3$ x p mass), proportional to **4th power of energy**, inversely proportional to **2nd power of bending radius**
- For multi TeV hadron colliders (LHC, FCChh) **handling of SR still important** (protection of SC magnets with beam screens)
- **Energy loss per turn** obtained by integral of power over one revolution
- ESRF storage ring (ESB, 6GeV): **~ 2.5 MeV/turn.**
- LEP II (**120 GeV**): **~ 6 GeV/turn**, or FCCee (ttbar flavor at **175 GeV**): **7.5 GeV/turn**
- **Circular e+/e- machines** of ~ 100 s GeV quite demanding with respect to **RF power** (and extremely long)

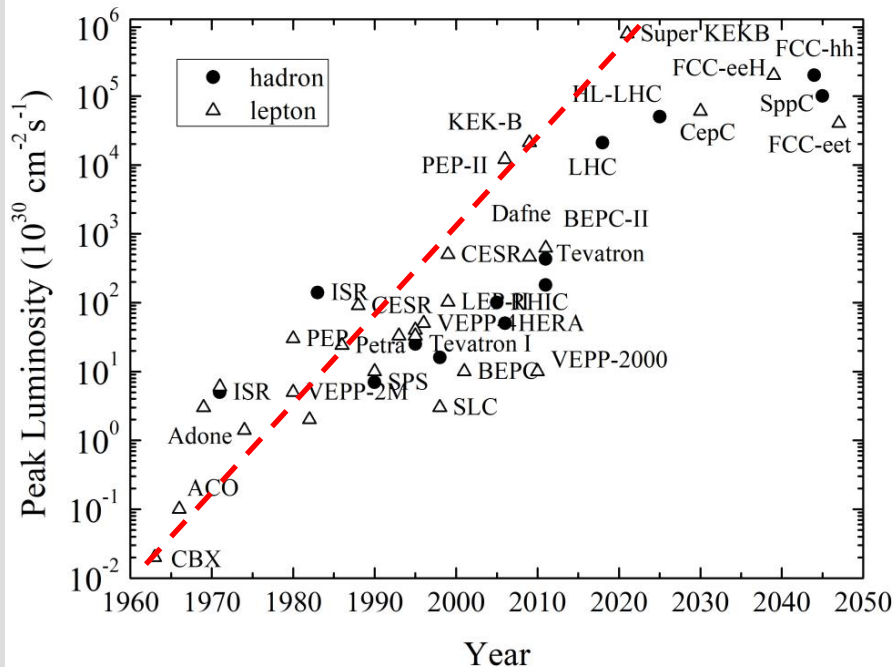

- **High-luminosity** frontier
- **Factories, high precision** physics measurements

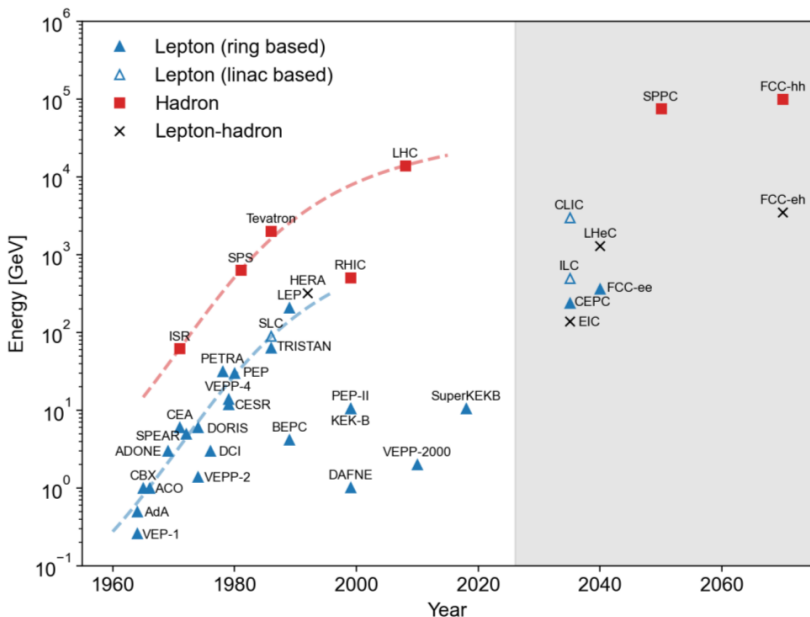
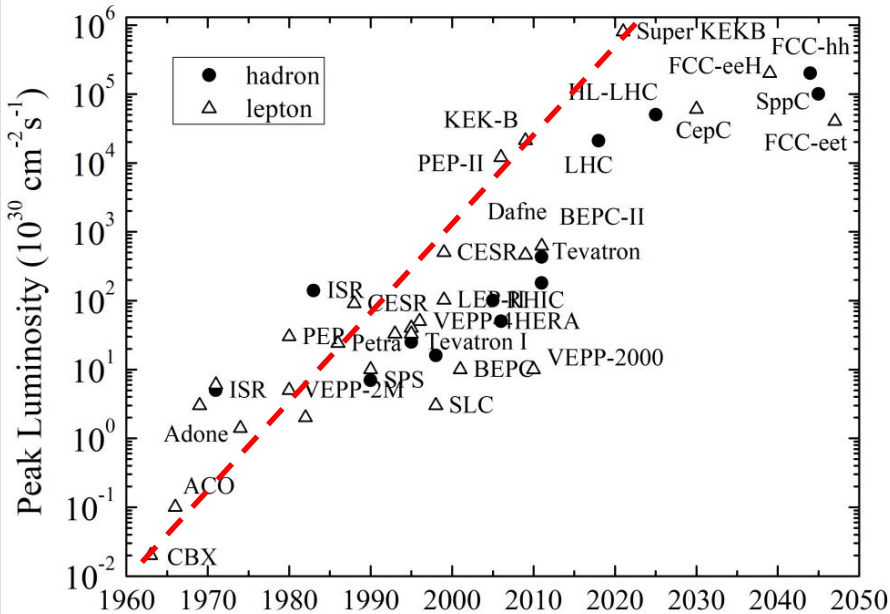

High-luminosity frontier

- Factories, high precision physics measurements

High-energy frontier

- Discovery measurements

- Before Higgs discovery

- LEP2 last large circular high-energy collider (120 GeV)

- Linear colliders (ILC, CLIC) considered for future (0.5 to 1.5 TeV)

- After Higgs discovery at 126 GeV

- Large circular colliders reconsidered (FCCee, CEPC)

- Integrated programs from Z up to the top, with integrated programs

- **Beam-beam tune-shift**, i.e. 1st order approximation to betatron tune change

$$X_{x,y} = \frac{Nr_e}{2pg} \frac{b_{x,y}^*}{s_{x,y}^* (s_x^* + s_y^*)}$$

- The luminosity becomes $L = f_{coll} \frac{\pi\gamma^2}{r_e^2} \frac{\xi_x \xi_y \varepsilon_x}{\beta_y} \left(1 + \frac{\sigma_x}{\sigma_y}\right)$

- For flat beams $\varepsilon_y / \varepsilon_x = \kappa \ll 1$ and $\kappa_\beta = \beta_y / \beta_x$

- **Horizontal tune-shift** $X_x \gg \frac{r_e}{2pg} \frac{N}{e_x}$ and **vertical**

one $\xi_y \approx \frac{r_e}{2\pi\gamma} \frac{N}{\varepsilon_x} \sqrt{\frac{\kappa_\beta}{\kappa}}$

- **Luminosity** becomes $L \gg f_{coll} g N \frac{X_y}{b_y}$

SuperKEKB Operation History

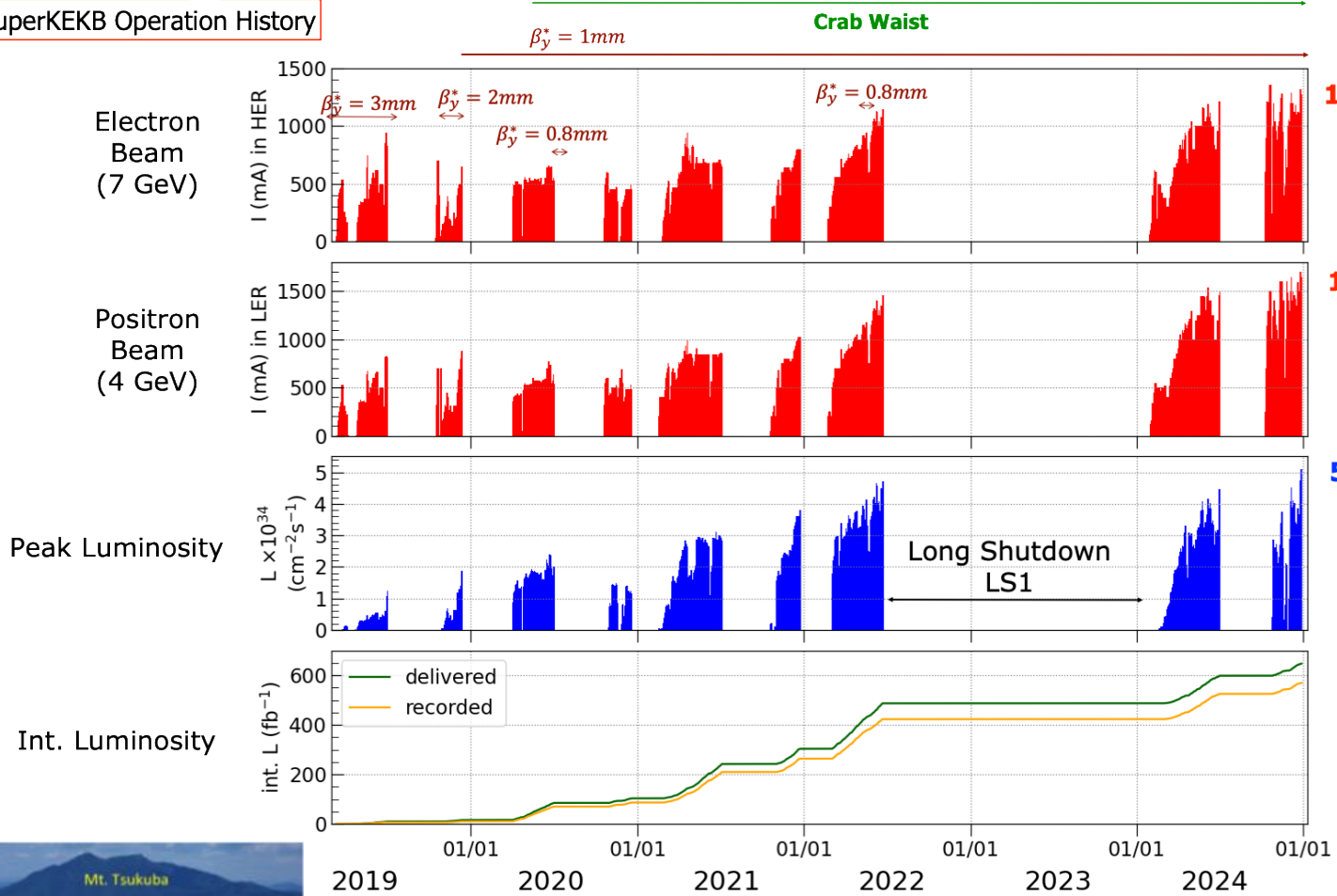

1.3 A

1.7 A

New Record !

$5.1 \times 10^{34} cm^{-2}s$



- Very large **90.7 km circumference** electron-positron collider to reach high luminosity (Z) and energy (top) with **4 IPs**
 - Reuse of tunnel for **hadron collider**
- **50 MW SR power** per beam
 - Main driver for **beam intensity**
- Two **separated rings** for e^+ and e^-
 - **Large crossing angle** of 30 mrad
- **Small equilibrium emittances** reached with large tunes
 - **Different optics** depending on energy
- **Top-up injection**
 - **Full energy booster** sharing tunnel with collider
- **Injector complex**
 - Linacs, positron conversion target, damping ring, transfer lines ...
- Many similarities with **CEPC**

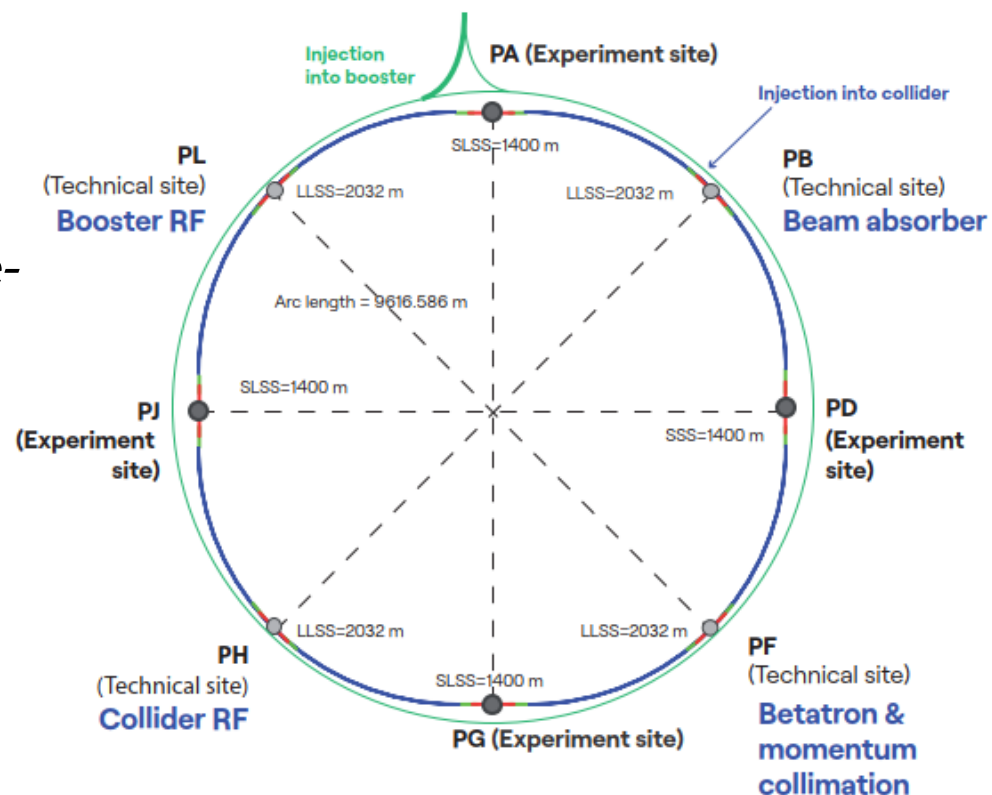

Nano-Beam Scheme

P. Raimondi

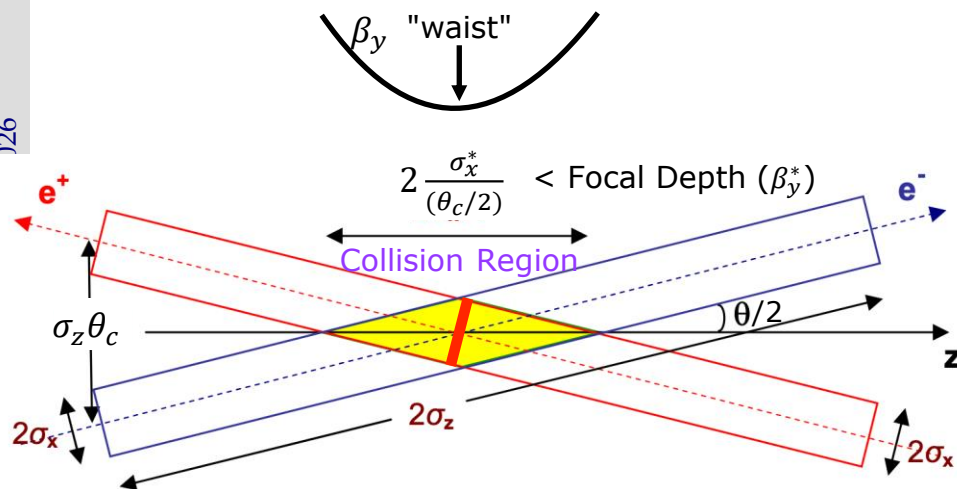

Effectively Very Short Bunch → "Hourglass"

"Head-On Collision"

$$\tilde{\sigma}_z = \frac{\sigma_z}{\Phi} = \frac{\sigma_x^*}{(\theta_c/2)} < 1\text{mm} \longleftrightarrow \sigma_z = 6\text{ mm SuperKEKB}$$

Key: Large Crossing Angle with Low ϵ_x

Crab-Waist Scheme

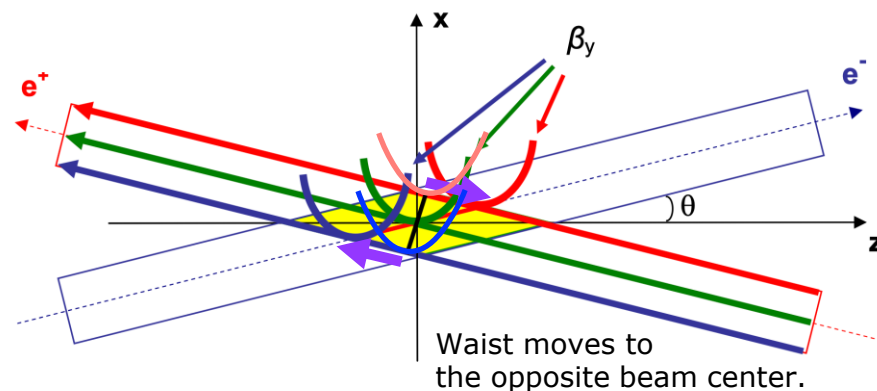
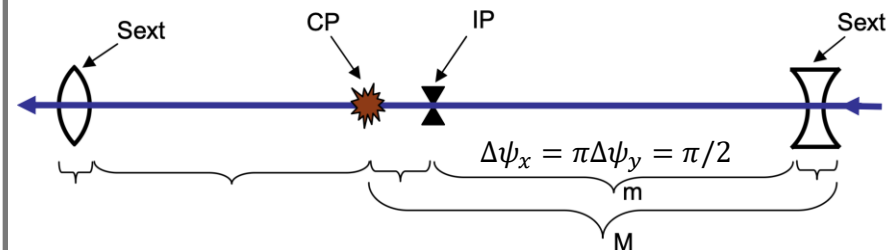

Suppression of Betatron Resonance

Related to Beam-Beam Interaction

Key: Strong Sextupoles with Specific Optics

CW OFF

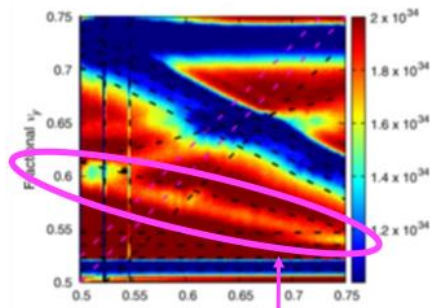

CW ON

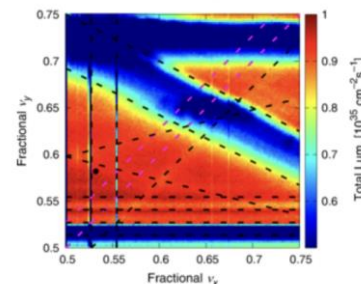

D. Zhou, et al.

- Luminosity

$$L = \frac{\gamma}{2e r_e} \frac{I_{tot} \xi_y}{\beta_y^*} R_G$$

- R_G a **geometric reduction factor**
- **Total intensity** I_{tot} given by SR power, assuming absence of other intensity limitations
- Maximized with **large beam-beam tune shift** ξ_y
 - ◆ At Z mode $\xi_y = 0.09$ per IP (compared with $\xi_y = 0.045$ per IP achieved at Z energy in LEP)
- Maximized with **small** $\beta_y^* \approx 1$ mm creating challenges for lattice design
 - ◆ Strong **chromatic aberrations** to be corrected locally
 - ◆ Small **Dynamic Aperture** (DA) require small **emittances**
 - ◆ For Z mode with “**nano-beam**” scheme
 - ◇ **Small peak bunch current**
 - ◇ **Large number of long bunches** required for large I_{tot}
 - ◇ **Maximum number** of bunches limited by **e-cloud** build-up

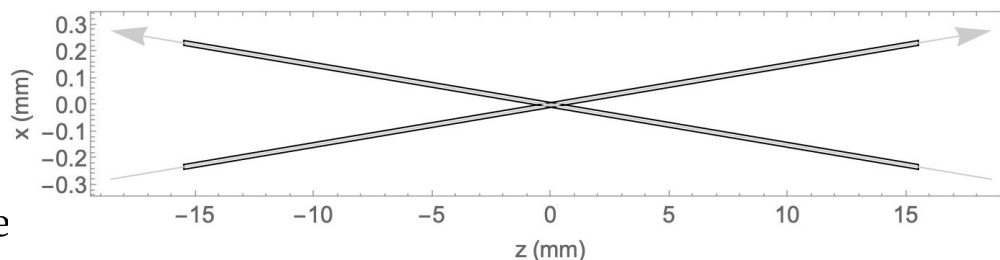

- “Nano-beam” collision scheme

- Kind of **ribbons** at the interaction point
- **Only fraction** of bunch interacts with opposite bunch at a given moment (**large Piwinski angle**)

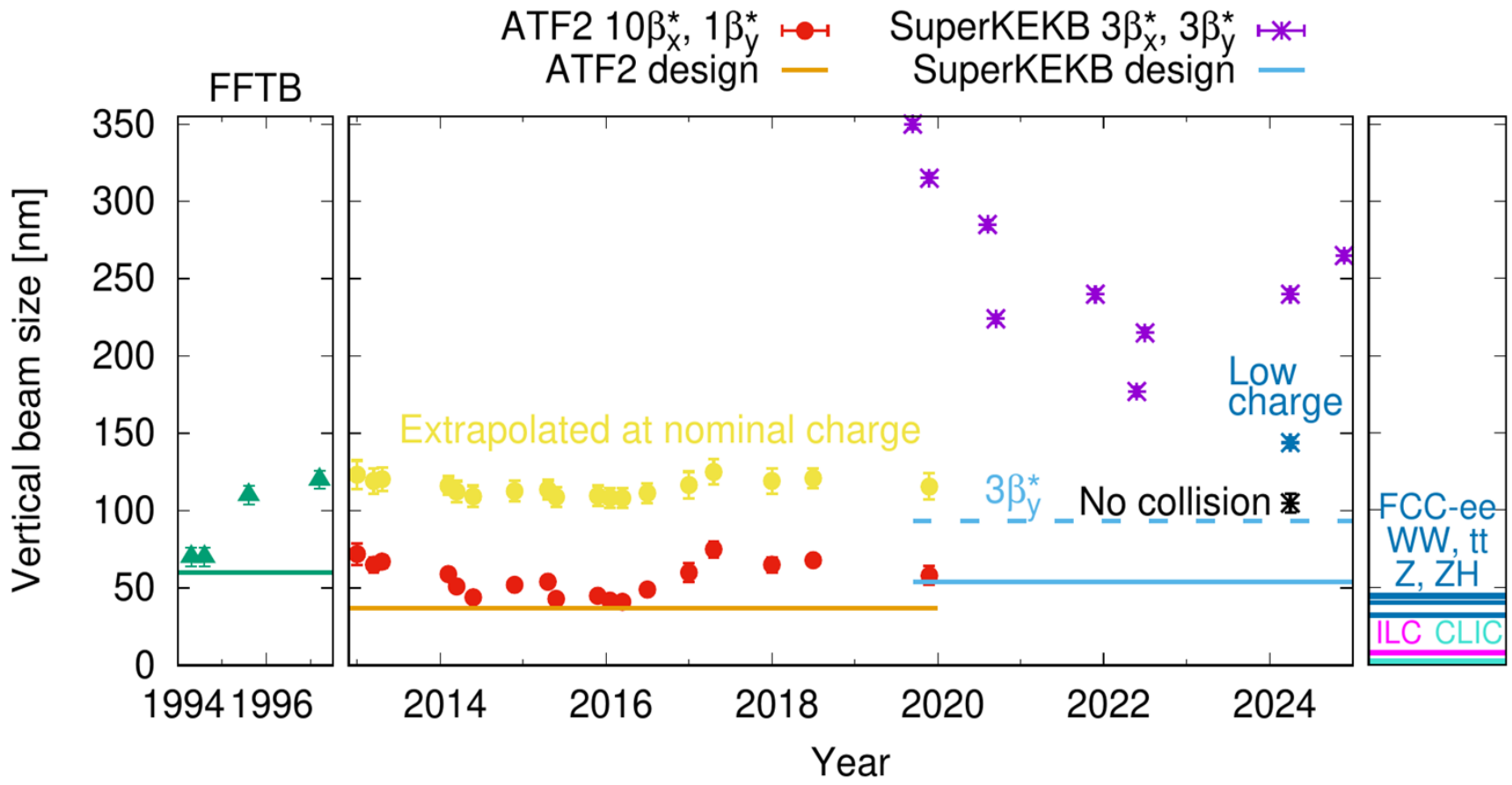

R. Tomas

- **Beam-strahlung**, i.e. SR due to field of opposing bunches, potential limitation
 - Increase of **equilibrium momentum spread** and **bunch length** (beneficial at low energy)
 - **Interception of hard beam-strahlung photons** challenging
- Limitations from **beam-beam effects**
 - **Synchro-horizontal betatron resonance** and instability constraining synchrotron and horizontal tunes

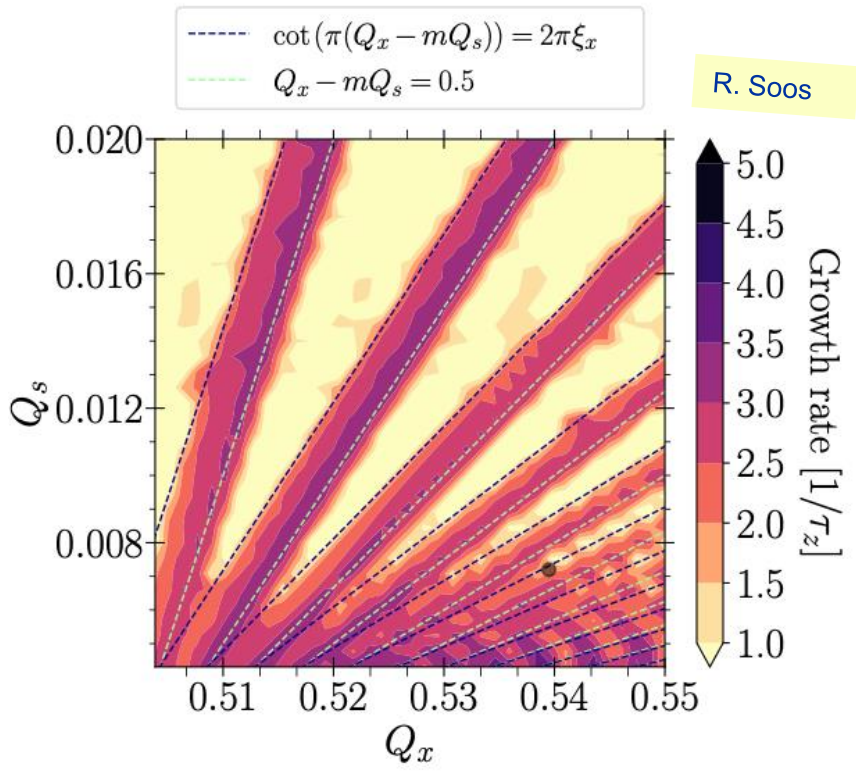

▪ Flip-flop mechanism

- Low (high) intensity bunch with more (less) perturbation
- Asymmetric effect on bunches

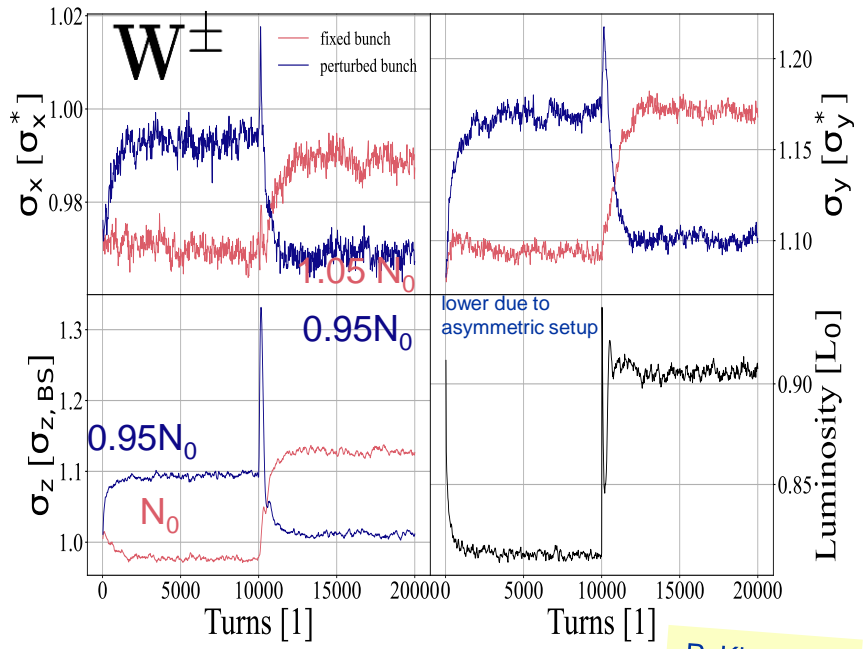

- ◆ **SR Absorbers (SRAs)** intercept photons with 50 MW total power per beam
 - Challenge to absorb power deposit on SRAs
 - Optimized for **high efficiency** to limit generation of **photo-electrons** (e-cloud)
 - At high beam energies, generation of **neutrons**
 - Absorbed as much as possible by lead blocks inside magnet
 - Residual radiation in tunnels

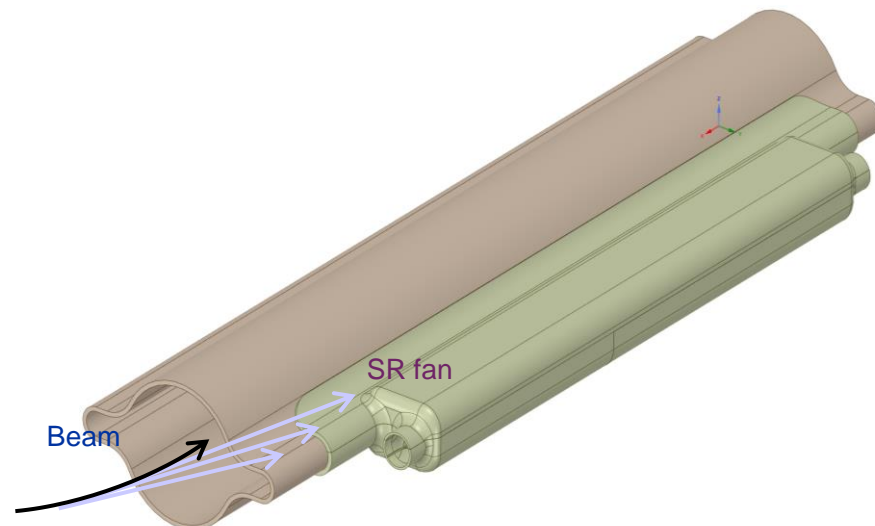
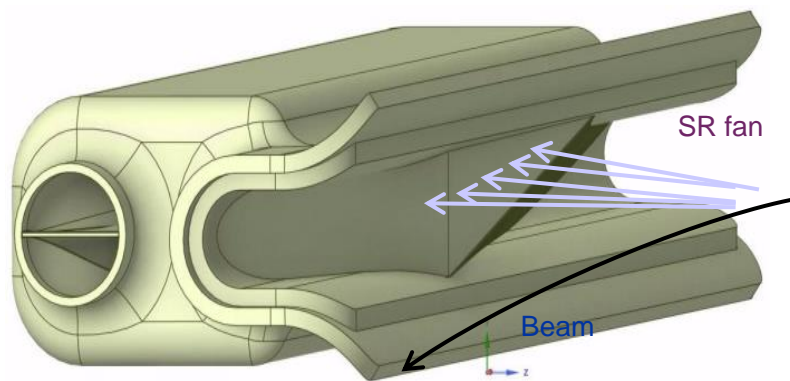
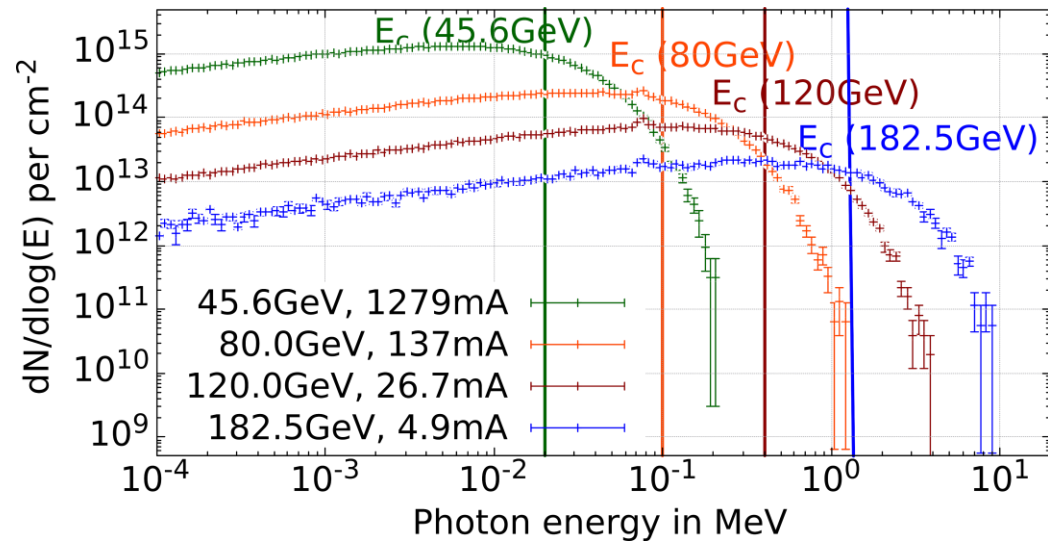

CEPC as a Higgs Factory: H, W, Z, upgradable to ttbar, followed by a SppC (a Hadron collider) ~125T, 30MW SR power per beam (upgradable to 50MW), high energy gamma ray 100Kev~100MeV

CEPC has two detectors

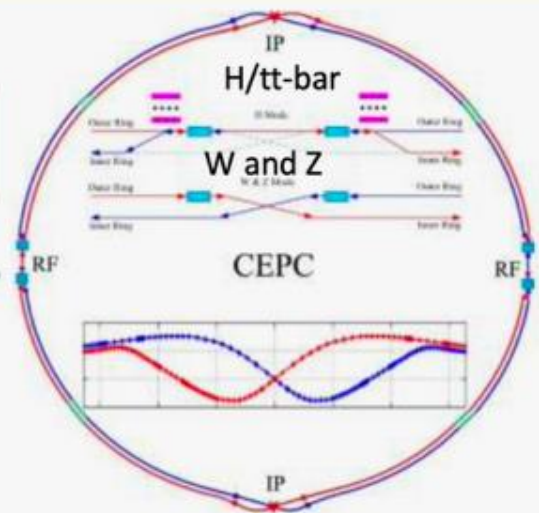
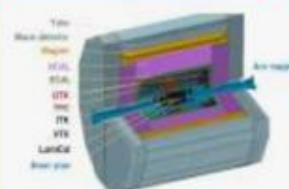

CEPC collider ring (100km)

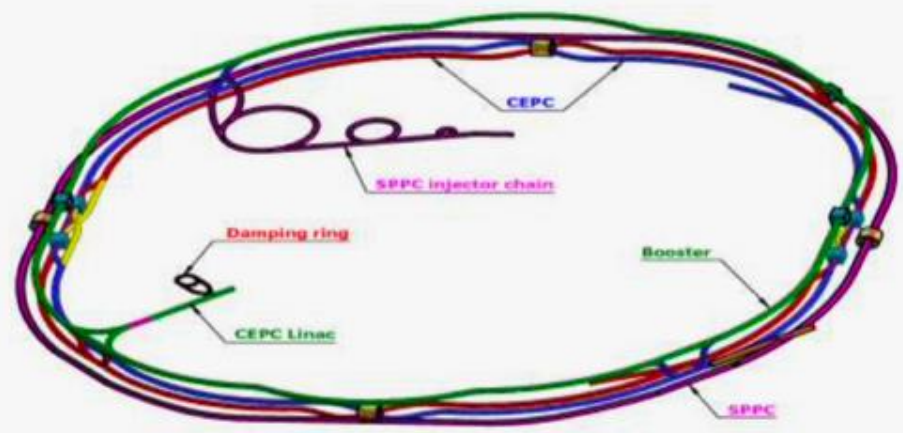

CEPC booster ring (100km)

CEPC TDR S+C-band 30GeV linac injector

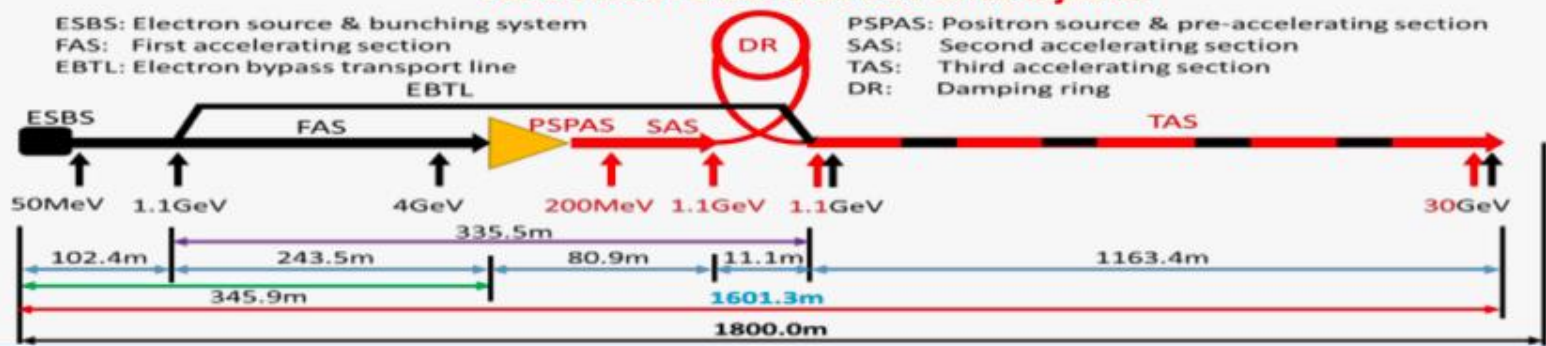

ESBS: Electron source & bunching system
 FAS: First accelerating section
 EBTL: Electron bypass transport line

PSPAS: Positron source & pre-accelerating section
 SAS: Second accelerating section
 TAS: Third accelerating section
 DR: Damping ring

Baseline

- $\sqrt{s} = 380 \text{ GeV}$, 2 IPs
- Main Linac length: 11.4 km
- Option for 550 GeV: +5 km from start
- Using **drive beam** for increasing RF efficiency @ high gradient (copper cavities)

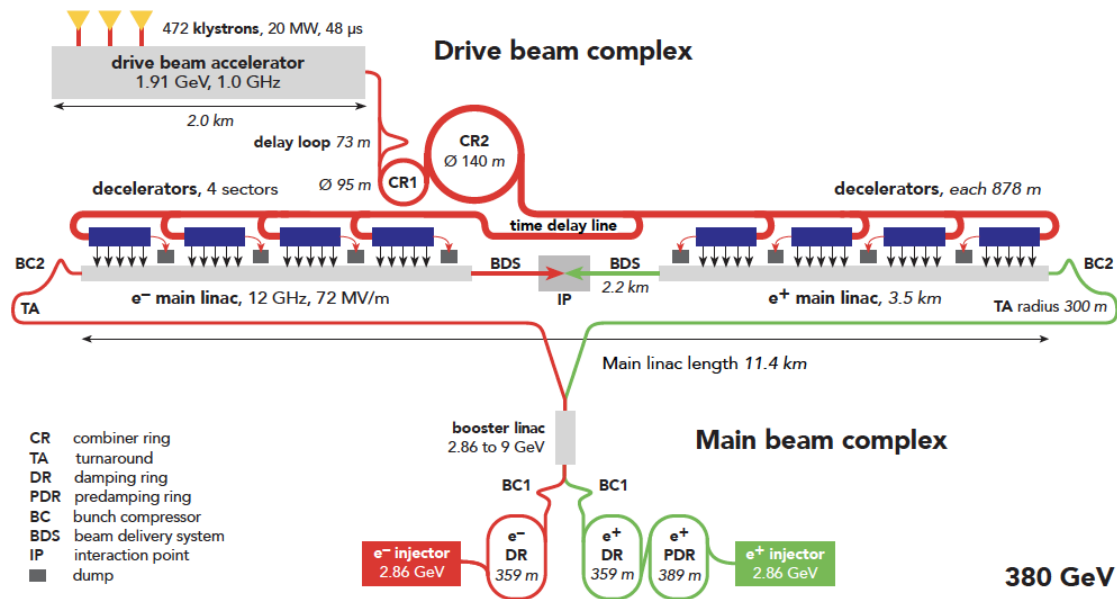

Upgrade to 1.5 TeV

- After ~10 years at 380 GeV
- Tunnel length extended to 29.6 km
- New high-gradient (100 MV/m) modules added
- One IP (with push-pool detectors), two IPs with higher rep. rate

Positives

- Polarization
- Above $t\bar{t}$ threshold
- Compact footprint, staged spending profile
- Mature technology demonstrated at CTF3

LCF

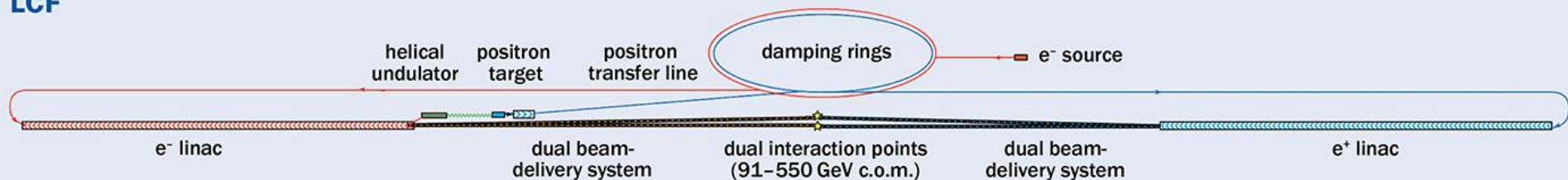

Baseline

- $\sqrt{s} = 250 \text{ GeV}$, 2 IPs
- Total length: 33.5 km
- Phased through Low power (LP) to Full power (FP)

Upgrade to 550 GeV

- After ~10 years at 250 GeV
- Requires a 2-year long shutdown, installation of additional SRF cryomodules
- No additional Civil Engineering

Positives

- Mature technology (ILC...)
- Polarised beams
- Staged
- Relatively small footprint

	CLIC	FCC-ee				LCF LP	LCF FP	
Circumference/length collider tunnel [km]	12.1	90.7				33.5		
Number of experiments (IPs)	2	4				2		
c.o.m. energy [GeV].	380	91.2	160	240	365	250	91.2	250
Longitudinal polarisation (e- / e+) [%]	80/0	-				80/30		
Nominal years of operation (equivalent)	8	3	2	3	4.5	3	1	3
Luminosity per IP above 0.99 \sqrt{s} [$10e34 \text{ cm}^{-2} \text{ s}^{-1}$]	1.3	140	20	7.5	1.4	1	0.28	2
Int. luminosity all IPs above 0.99 \sqrt{s} per year [ab ⁻¹]	0.32	69	9.6	3.6	0.67	0.24	0.067	0.48

- **Efficiency ($\leq 300\text{--}350$ GeV):** FCC-ee delivers more luminosity per MW, more Higgs for shorter time
- **Flexibility:** FCC-ee can scan 90 \rightarrow 240 GeV @ very high luminosity
- **Polarisation:** linear collider baselines include e⁻ polarisation; LCF can add e⁺ polarisation



Since 2023

HALHF

Hybrid, Asymmetric, Linear Higgs Factory

- e^- acceleration in **e^- beam-driven plasma wakefields**
- e^+ acceleration in radiofrequency cavities (C^3 technology)
- To make most effective use of space \rightarrow collision of polarised 375 GeV e^- with 42 GeV e^+

Advantages:

- + most advanced wakefield collider concept \rightarrow avoids e^+ acceleration in plasma
- + compact footprint, ~ 5 km



Since 2024

ALIVE

A Linear accelerator for Very high Energies

- e^- and e^+ acceleration in single stage **p^+ beam-driven plasma wakefields**
 - Enabled by the energetic and short p^+ drivers
 - p^+ drivers: high-rep.-rate 500 GeV synchrotron

Advantages:

- + avoids staging
- + compact footprint
- + scaling to higher energies (10 TeV)



Since 2025

10 TeV

Design Initiative for a 10 TeV pCM Wakefield Collider

Technology candidates:

- Laser-Driven Plasma Wakefields
- Beam-Driven Plasma Wakefields
- Structure Wakefields

Collider type:

- e^+e^-
- e^-e^-
- $\gamma\gamma$



Goals include delivery of:

- + end-to-end design study report in 2028
- + roadmaps and resource estimates



Since 2023

HALHF

Hybrid, Asymmetric, Linear Higgs Factory

Challenges:

High repetition rate plasma operation and cooling, Staging, Production and acceleration of polarized beams, BDS design,...

10-15 years of R&D

ESPP Input #57: HALHF: a hybrid, asymmetric, linear Higgs factory using plasma- and RF-based acceleration ([link](#))



Since 2024

ALiVE

A Linear accelerator for Very high Energies

Challenges:

High power synchrotron, Proton Bunch Compression, Plasma Source Development, Positron Acceleration, Energy Transfer Efficiency, Beam Quality Preservation,...

ESPP Input #210: Proton-Driven Plasma Wakefield Acceleration for Future HEP Colliders ([link](#))



Since 2025

10 TeV

Design Initiative for a 10 TeV pCM Wakefield Collider

Chosen design constraints:

$E_{z,avg} > 500 \text{ MeV/m}$
 $\mathcal{L}/P_{tot} > 10^{32} \text{ cm}^{-2}\text{s}^{-1} \text{ MW}^{-1}$

ESPP Input #98: Design Initiative for a 10 TeV pCM Wakefield Collider ([link](#))

electron-hadron Colliders

- **Hadron storage Ring (RHIC Rings)**
40-275 GeV (**existing**)

- 1160 bunches, 1A beam current (3x RHIC)
- bright vertical beam emittance 1.5 nm
- Strong hadron cooling

- **Electron storage ring 5–18 GeV, ~3.8 km**

- many bunches (1160 – 290)
- large beam current, 2.5 A → 9 MW S.R. power
- S.C RF cavities
- Polarized bunches (up to 70%)

- **Electron rapid cycling synchrotron 0.75-18 GeV**

- 1-2 Hz
- Spin transparent due to high periodicity

- **High luminosity interaction region(s)**

- $L = 10^{34} \text{cm}^{-2} \text{s}^{-1}$
- Superconducting magnets
- 25 mrad Crossing angle with crab cavities
- Spin Rotators (longitudinal spin)
- Forward hadron instrumentation

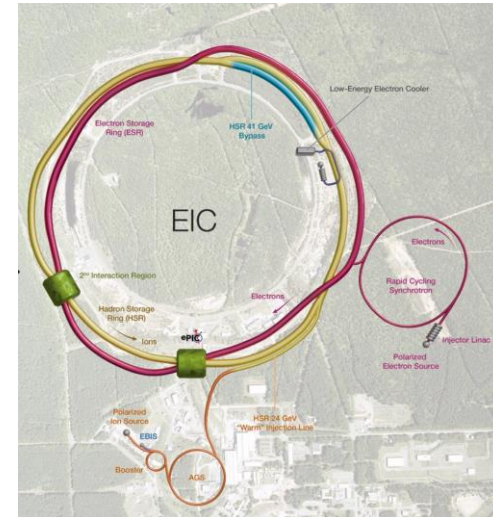
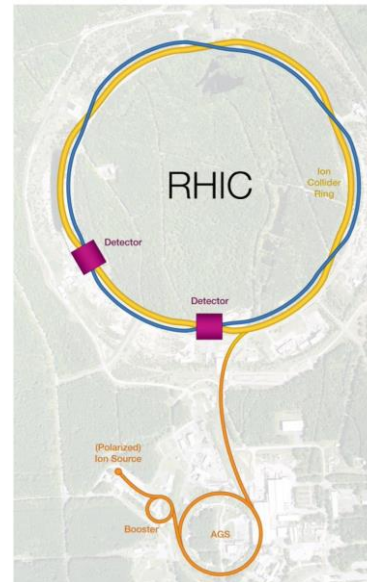
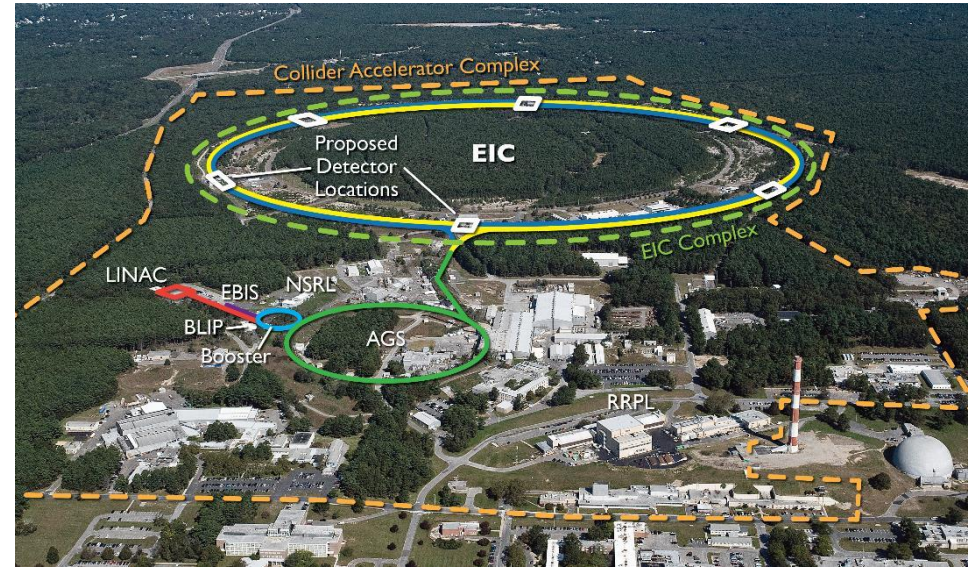

- 50 GeV electrons on 7 TeV protons

- Accelerator :

- 3-turn high-current Energy Recovery Linac (ERL) in a new tunnel tangential to the LHC at IP2 (~9 km long)
- High-intensity operation to be demonstrated in PERL, including challenges in recovery efficiency + beam-loss control

- Performance:

- Total integrated luminosity $\sim 1 \text{ ab}^{-1}$ over ~6 years

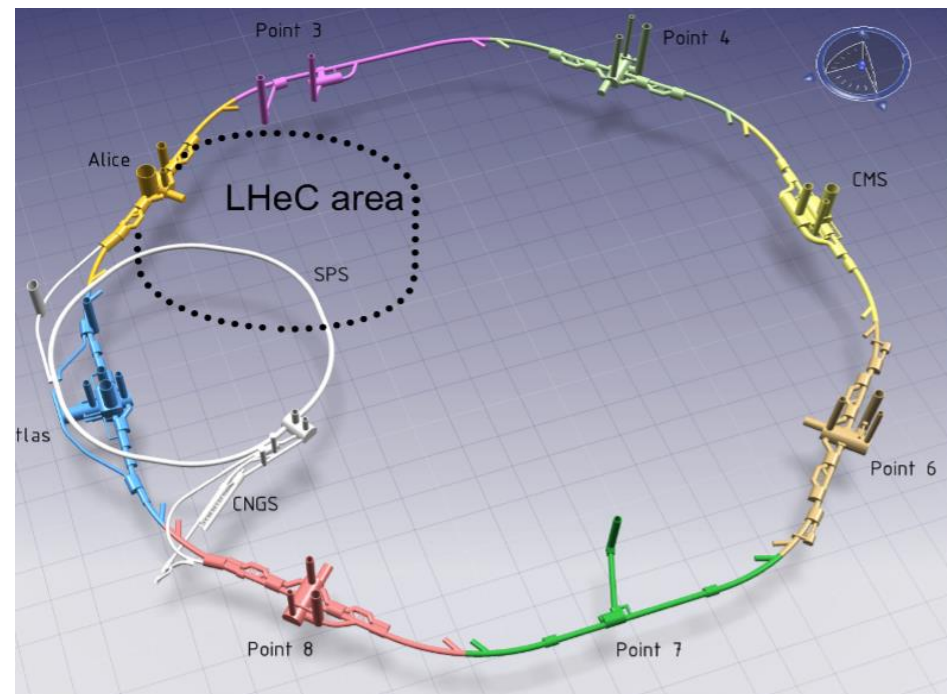

Muon Collider

A credible *non-parton* route to probing the “10 TeV energy scale” with lepton collisions, if the key feasibility issues can be cracked. Clean lepton initial state at multi-TeV; strong direct reach for heavy new states.

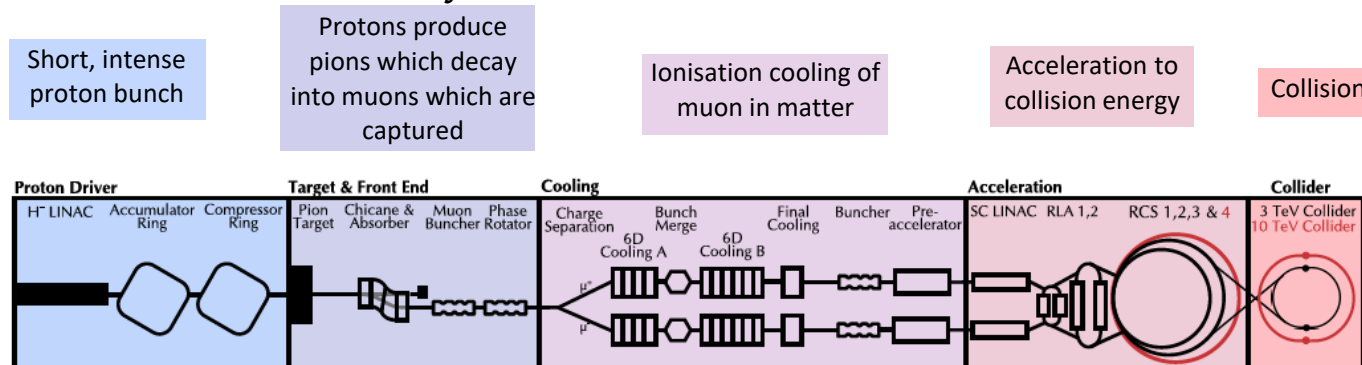

- CERN implementation: reuse SPS & LHC tunnels for parts of the acceleration chain; could reach up to ~7.6 TeV c.m, with a practical first stage ~3.2 TeV

Parameter	Unit	3 TeV	10 TeV	3.2 TeV	7.6 TeV
L	$10^{34} \text{ cm}^{-2}\text{s}^{-1}$	1.8	18.75	0.74	7.9
N	10^{12}	2.2	1.8	2.2	1.8
f_r	Hz	5	5	5	5
P_{beam}	MW	5.3	14.4	5.3	11
C	km	4.5	10.7	11	11
B_{dipole}	T	11	15	4.8	11
Collider techn.		Nb3Sn	HTS	NbTi	Nb3Sn

More realistic constraints in the design

- IR quadrupoles meet magnet requirements.
- Assess impact of L^* , shielding thickness, and interconnect length on optics and performance.
- *Proof of concept* shows combined-function magnet constraints are manageable.

Vertical periodic machine deformation (spread neutrino radiation)

- Implemented in regular arc cells, with cancellation of vertical dispersion.
- Ongoing studies to evaluate feasibility in local chromatic correction sections.

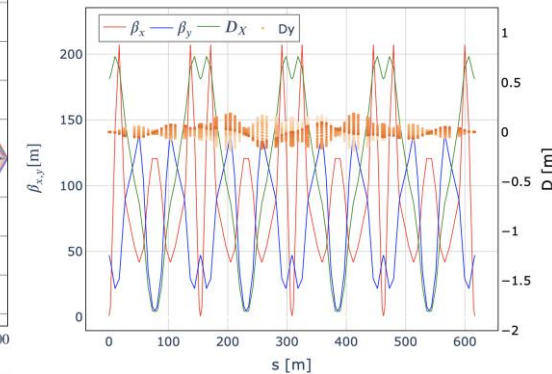
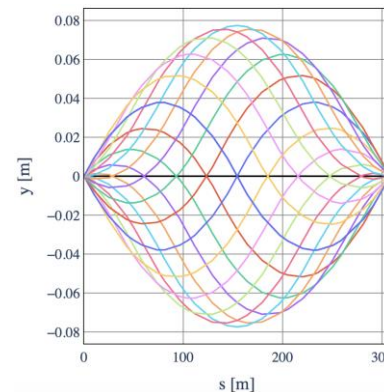
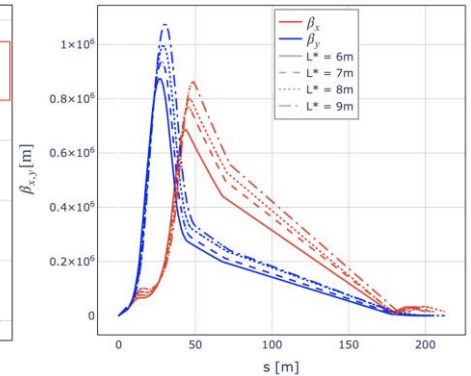
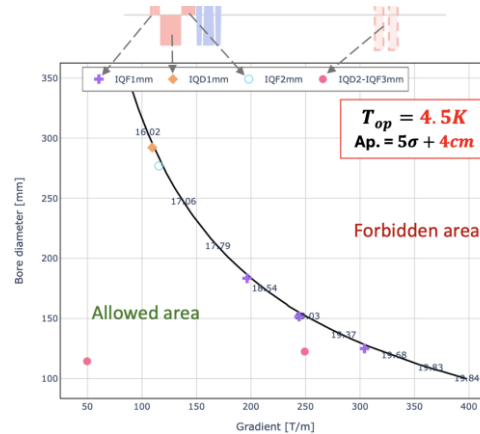

Project	IP	Z-pole (91.2 GeV)	WW (160 GeV)	Higgs (230-250 GeV)	Top (365 GeV)	Higher Energy
FCC-ee	4	205 ab ⁻¹ 4 year	19 ab ⁻¹ 2 year	11 ab ⁻¹ 3 year	3 ab ⁻¹ 5 year	—
FCC-hh	2	—	—	—	—	84.6 TeV: 0.6 ab ⁻¹ / year /IP
LEP3	2	53 ab ⁻¹ 5 years	5 ab ⁻¹ 4 years	2.5 ab ⁻¹ 6 years	—	—
Linear colliders	1	0.07 ab ⁻¹ 1 year	—	2 ab ⁻¹ 3 years	CLIC: 4.4 ab ⁻¹ 10 years	550 GeV: 8 ab ⁻¹ 1.5 TeV: 4 ab ⁻¹ 10 years
LHeC	1	—	—	—	—	1 TeV for 6 years
Muon Collider	2	—	—	—	—	10 TeV: 1.1 ab ⁻¹ 8 year

Operation at 550 GeV or higher would offer competitive programmes in Higgs and top-quark physics,

Thank you for your
attention...